

Mitigation of Dynamic Load Balancing through Real-Time Power Control in Smart Grids

Ehsan Ramezan, Hamid Reza Zolfagari

Sharif University of Technology, Tehran, Iran

Abstract—Demand response is known as one of the basic components of smart grids that plays an important role in shaping load curves. In most of the prior reports on applying demand response programs, reactive power and load dependency to voltage magnitude have been ignored in distribution grids. In this paper, firstly, we show that the ignorance of the mentioned phenomena can cause a mismatch between the expected value of demand response and the experimental value. This mismatch is known as the demand response mismatch (DRM), which is dependent on some parameters such as load type, load reduction percentage, and network power factor. To overcome this problem, this paper presents a reactive power control model. In addition, a mixed integer nonlinear program is proposed to find the optimal size and location of STATCOMs and the optimal transformer tap settings that minimize the DRM. In this paper, the 16-bus U.K. generic distribution system (UKGDS) is employed to prove the capability of the presented method in DRM reduction.

I. INTRODUCTION

Smart grids, by using communication, information, and control systems, can increase the quality and reliability of supply in distribution grids among different sources and components of the grids, demand response (DR) programs act as the key components of smart grids. Some of the

advantages of DR programs are decreasing electricity market-clearing price; increasing the capacity of electricity resources, decreasing investment on transmission infrastructures; and decreasing the blackouts and Market power mitigation [1]. DR programs are divided into two categories: incentive-based programs and price-based programs. In the price-based programs, the distribution operator decreases the system peak load by changing the electricity price under different tariffs.

In incentive-based programs, consumers reduce their consumption by receiving incentives from the distribution operator [2]. In [3], the authors have presented a model for designing consumers' optimal set of consumption under DR programs and considering the operation constraints of distribution networks. This model has been presented as an integrated optimization problem in which maximization of the consumers' social welfare and reducing the distribution network losses are considered as the objective function. Similar research has been done in [4], and a model for setting consumers' optimal consumptions is attained using DR pricebased programs.

Reference [5] has employed giving rewards to carry out incentive-based programs. The amount of reward is set based on the impact of consumers' load reduction on the voltage of other buses. Moreover, consumers authorized the distribution company to determine the desired level of load reduction based on operation constraints of the distribution network. In

[6] and [7], voltage control through the demand side management has been investigated. In [7], this fact has been noticed that there has not been enough research done on the potential of real-time demand response for providing ancillary services. Therefore, in the proposed model, execution of DR programs by a decentralized model called "Grid Explicit Congestion Notification" has been presented to utilize the appliances that have real-time DR capability. It has been shown that implementation the proposed model, guarantees reactive power control in the network with no more need to new compensators, devices for reactive power compensation and voltage control. DR frequency control is another ancillary service that can be provided by the demand side management.

In [8], the purpose of running DR is controlling the frequency of grid in the presence of wind generators. DR is presented as a frequency regulator mechanism in microgrids in this algorithm. The main goal of the presented algorithm is achieving minimum load reduction by applying constraints on house appliances. In [9], a decentralized algorithm is presented to utilize appliances to control system frequency.

Supposing that each appliance needs a minimum amount of time to respond to the load reduction, the algorithm has been capable of controlling the system frequency in the critical conditions effectively.

In [10], the concept of DRM programs was presented for the first time. DRM presented a new challenge in employing direct-load reduction programs. This article discussed only the mismatch active demand response and neglected this mismatch impact on reactive power.

Since in practice reducing at a bus will increase the bus voltage load consumption is dependent on voltage thus the level of the expected load reduction will be different from requested reduction even when consumers undertake the requested load reduction. This causes a conflict between the distribution company payments to the consumers and the consumers' expected amount to receive. This conflict causes consumers' dissatisfaction with executing DR programs and also reduces their motivation for participating in DR programs.

The mismatch demand response presented in [10] only considers the active loads and neglected reactive loads. In this paper, the definition of "Active and Reactive Demand Response Mismatch" (ARDRM) is presented in the next section. Then in the third section the ARDRM is modeled and an algorithm for reducing and eliminating the DRM is proposed. The numerical results demonstrate the effectiveness of the proposed method.

II. DEMAND RESPONSE MISMATCH

Static load modeling and its impact on DR programs were investigated in [10] and also, the new concept of mismatch in DR programs was presented, which is defined as (1).

$$DRM = \frac{\text{Expected DR} - \text{Achieved DR}}{\text{Achieved DR}} \quad (1)$$

$$\text{Expected DR} = P_{Li} \times x_i \quad (2)$$

$$\frac{P_{Li}}{V_i} \quad (3)$$

$$\text{Consume After DR} = P_{Li} \times (1 - x_i) \times \left(\frac{V_i}{V_{0,i}} \right) \quad (4)$$

$$\text{Achieved DR} = P_{Li} \times \left(1 - \frac{P_{Li} \times (1 - x_i)}{V_i} \times \left(\frac{V_i}{V_{0,i}} \right) \right) \quad (5)$$

Where P_{Li} represents the active power at bus i , x_i is the load reduction amount in percentage, and α is the static parameter which shows a degree of active power dependency to voltage. Also, $V_{0,i}$ and V_i are the voltages before the load reduction and after it, respectively.

Once the distribution operator requests x_i of load reduction from consumption P_{Li} , a load as large as $P_{Li} \times (V_{0,i})^\alpha \times x_i$ will be created in the network practically. In the static load modeling, power consumption is determined by voltage $V_{0,i}$ and α . The network operator calculates the load reduction amount before the load reduction and without considering static load modeling.

The network operator achieves the load reduction amount achieved in (3) based on the voltage after the load reduction.

$V_i / V_{0,i}$ ratio is definitely more than 1, since the voltage rises after the load reduction at bus i . This is while the consumers are not aware of their voltage during consumption and consider their own load as constant power, thereby thinking of the achieved amount in (2) as their load reduction amount. Therefore, consumer expect from the distribution company to take this amount and (9), P_{Gi} and Q_{Gi} are the injected active and reactive power into bus i of the network respectively. P_{Li} and Q_{Li} are also the load's active and reactive power mismatch into account.

The actual amount of consumers' power consumption will be determined after the load reduction by the network operator as shown in equation (4). This subject can cause a conflict between the network operator and consumers.

By substituting (2) and (4) in (1), we have (5) which states active demand response mismatch (ADRM). This equation states the ADRM in percentage. Since the reactive power as the active power consumption in bus i is dependent on voltage, it is needed to investigate its mismatch value. Therefore, we

also introduce reactive demand response mismatch (RDRM) in this section.

Concerning the definition presented in (1), equation (6) results in RDRM by expanding (2) and (6) for the active load. In (6), β is degree of reactive power dependency to voltage, and Q_{Li} is the amount of reactive power consumption at bus i in the rated voltage.

$$ADRM = \frac{P_{Li} \times (1 - x_i) \times \left(\frac{V_i}{V_{0,i}} \right) - P_{Li} \times x_i}{P_{Li} \times x_i} \quad (5)$$

$$RDRM = \frac{Q_{Li} \times (1 - x_i) \times \left(\frac{V_i}{V_{0,i}} \right) - Q_{Li} \times x_i}{Q_{Li} \times x_i} \quad (6)$$

III. MODELING THE PROPOSED METHOD TO REDUCE THE ARDRM

Considering the fact that the main challenge resulted from the load's voltage dependency was presented in the previous section, reactive power control can be one of the solutions for this problem.

Therefore, to remove or reduce the ARDRM, a model will be presented in which optimal coordination is done between the compensation reactive power sources and voltage control devices (such as on-load tap changer (OLTC) and voltage regulator (VR) transformers). In this model, the optimal localization of reactive power compensators and optimal setting of OLTC and VR are done to improve the voltage profile of the network and to reduce.

In order to control reactive power, STATCOM is used, since it has a faster response to reactive power injection requests and it makes fewer harmonics in comparison with other compensators.

STATCOM to other voltage regulating devices (such as thyristor controlled reactor and static var compensator) a STATCOM is selected due to its faster response, reduced smaller dimensions [11]. The problem of removing the mismatch can be implemented in the form of an optimization problem as following. In (7), the cost function, F , is minimized on the sum of the I_D set of busses that have DRM.

$$\text{Min } F = ADRM + RDRM \quad (7)$$

parameters ($\alpha=\beta=2$) are taken into account. Voltage variations of $\pm 10\%$ are taken into account for the upper and lower voltage variations based on the standards. And the primary tap settings values of the transformers equipped with OLTC and VR are also set to 0.98.

B. DRM Results

In this work, it is assumed that, all the loads in the distribution network participate in DR program. The power factors which determine the ratio between the active and reactive powers are considered as 0.98, 0.95, 0.9, 0.85, 0.8 lagging. In all the power factor cases, it is assumed that the active power values for loads are the same reported in [12], and only their reactive power values vary corresponding to the assigned power factor. Also, for each power factor, six different scenarios of load reduction are considered.

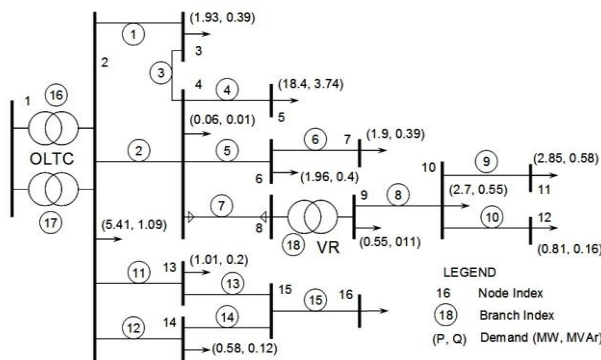

Figure 1. Single Line Diagram of the U.K Generic Distribution System Under Study.

TABLE I. STATIC LOAD MODEL PARAMETERS

Load Type		Residential		Commercial		Industrial	
		α	β	α	β	α	β
Summer	Day	0.72	2.96	1.25	3.50	0.18	6.00
	Night	0.92	4.04	0.99	3.95	0.18	6.00
Winter	Day	1.04	4.19	1.50	3.15	0.18	6.00
	Night	1.30	4.38	1.51	3.40	0.18	6.00

Because of the load reduction, both of the active and reactive powers decrease under the specified power factor for each scenario. For all of the mentioned scenarios, the DRM are calculated as in (5) and (6).

Figs. 2 and 3 show the variations in DRM on both power factor and load reduction for commercial winter day loads, respectively. It could be seen in Figs. 2 and 3, both ADRM and RDRM increases while power factor for all the load models. Also, it could be seen that in Fig 2-3 RDRM for commercial winter is more than ADRM for same power factor and amount load reduction.

To investigate the effect of load reduction on ADRM under constant power factor condition, Figure 4 indicate this mismatch has the maximum value of 11.1% for the constant

impedance loads and the minimum value of 0.72% for the industrial loads.

The results indicate that ADRM decreases when the load reduction percentage increases, and the highest decrease in ADRM is 3.6%. Actually, because of the active power reduction, the reactive power also reduces and the voltage increases, and based on static load modeling, its consumption moves towards that of the constant power state when the voltage increases.

Also, by comparing Figure 5 and Figure 4, it can be understood that the percentage of mismatch is varied for different loads. Moreover, the ADRM and RDRM values can be different too. This matter will be significant when we want to reduce the active and reactive power to a specific value, and this will be impossible due to the difference between these two factors. Thus, because of the difference between active and

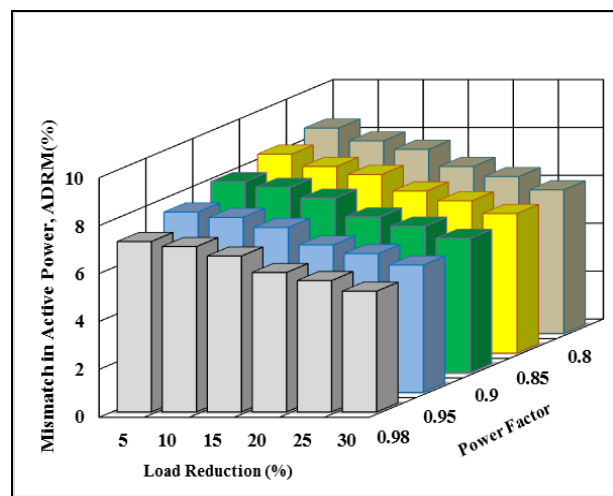

reactive powers static parameters, the active and reactive demand decrease.

Figure 2. Active demand response for commercial winter load with different power factor and load reduction at day time.

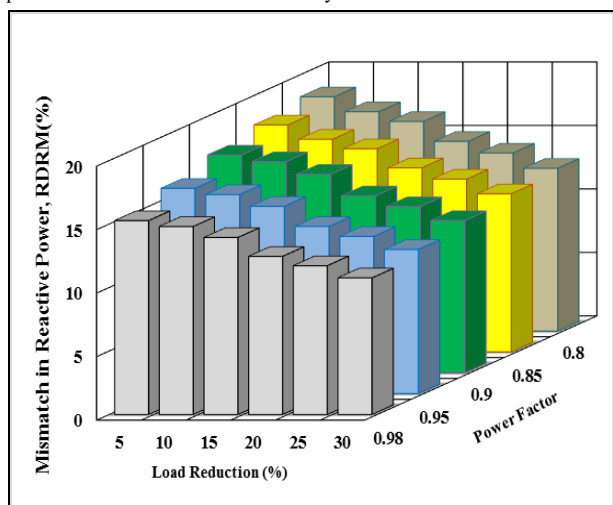

Figure 3. Reactive demand response for commercial winter load with different power factor and load reduction at day time.

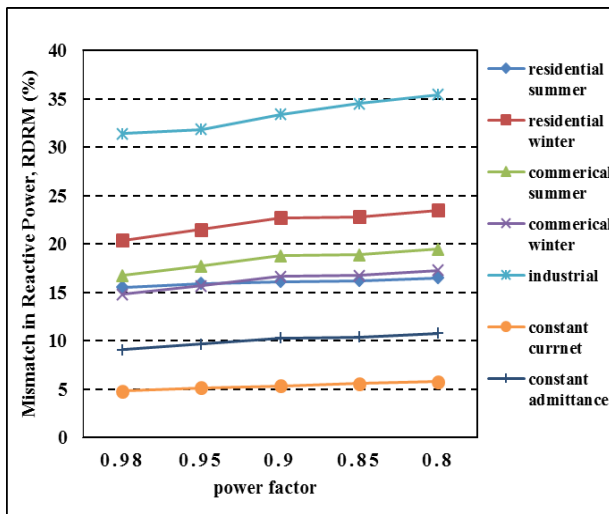

Figure 4. Active demand response mismatch with 10% reduction.

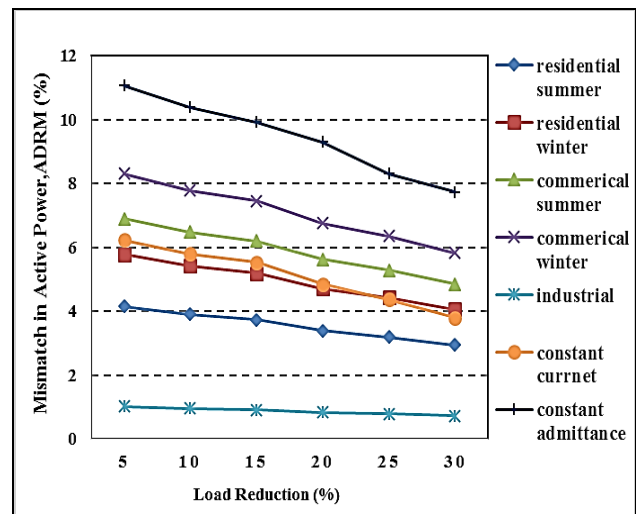

Figure 6. Active demand response mismatch with constant power factor of 0.85.

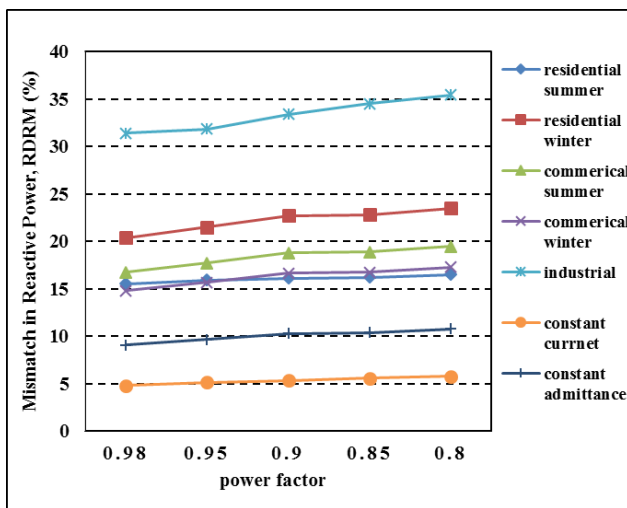

Figure 5. Reactive demand response mismatch with 10% reduction.

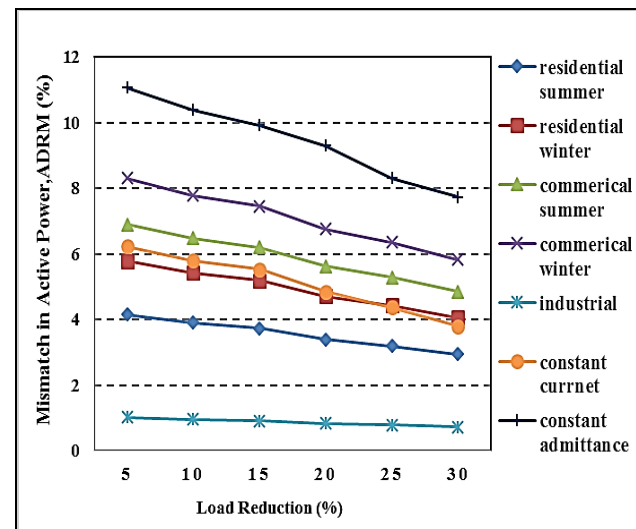

Figure 7. Reactive demand response mismatch with constant power factor of 0.85.

In Figure 6 the effect of power factor impact on different percentages of load reduction is investigated. Figure 6 shows that with an increase in the network power factor, ADRM decreases. Actually, power factor changes cause more variations in the DRM than the load reduction changes do. In Figure 7, the simulations related to the effect of power factor on RDRM are shown. In this figure, supposing that all the loads have 10% of load reduction with different power factors in the network, it can be seen that as power factor decreases, RDRM increases. When the network power factor decreases, the reactive power of the network increases and causes more voltage drop in the network buses. Now, if the network experiences emergency conditions and needs to execute DR programs, DRM increases both for the active and reactive demands in conjunction with an increase in the network power factor, since more load reduction and a lower power factor are needed. The sensitivity of the reactive demand response mismatch is more than that of the active demand response mismatch due to the higher sensitivity of reactive power to voltage variations.

The static parameter of its power consumption is also greater or equal to that of the active demand response mismatch for all loads except for the industrial loads. The effect of load reduction and power factor on DRM is investigated here.

Considering the same load reduction requested from all of the network buses, which results in the network's whole load reduction and results in different ADRMs and RDRMs for every bus of the network getting far from the reference bus. This increase will be much higher for RDRM rather than for ADRM.

Based on the simulations and the contents of Table II, the ADRM and RDRM values are different; for example, ADRM and RDRM are 6% and 22.2% for residential loads respectively. As it can be seen, the sensitivity of reactive power variations and its higher dependency on voltage

causes a considerable increase in the DRM of buses that have a higher voltage drop and are the furthest from the

The simulations are for load reduction of 10% at 0.8 power factor lagging with and without the coordination between

TABLE III. SOLUTION FOR 10 % REDUCTION OF COMMERCIAL WINTER NIGHT LOADS AT 0.8 POWER FACTOR

Constraints		Solution							
		$\sum_{i \in \Omega} Q_{Si}$ (MVar)	N_i Node	Tap Values		Without Transformer Tap Coordination		With Transformer Tap Coordination	
n	$\sum_{i \in \Omega} Q_{Si}$ (MVar)			VR	OLTC)(% ADRM)(% RDRM)(% ADRM)(% RDRM
	2.5	2.5		0.9001	0.9355	5.32	12.69	3.02	6.58
	2.5		11,12	0.9065	0.9365	4.59	10.93	2.38	5.12
				0.9060	0.9365	4.65	11.08	2.43	5.26
			11,12	0.9141	0.9379	3.29	8.70	1.24	2.55

reference bus.

TABLE II. DRM ANALYSIS OF INDIVIDUAL NODES FOR DIFFERENT CASES OF LOAD MODELLING WITH 5% LOAD REDUCTION AT 0.85 POWER FACTOR

Bus No.	Case 1		Case 2	
	$\sum_{i \in \Omega} Q_{Si}$ 1.25	$\sum_{i \in \Omega} Q_{Si}$ 3.50	$\sum_{i \in \Omega} Q_{Si}$ 1.50	$\sum_{i \in \Omega} Q_{Si}$ 3.15
	ADRM	RDRM	ADRM	RDRM
	%	%	%	%
	3.3			6.3
	6.4	13.2	7.3	11.7
	9.5	29.3	11.5	25.8
		27.9	10.8	24.2
Sum DRM	5.4	11.1	5.9	9.5

The contents of Table II indicate that in buses like bus 3 and 7, which are close to the reference bus and have less voltage drop, ADRM is less than that of buses like bus 11 and 12, which are far from the reference bus. These variations will be considerable when we want to observe their effect on reactive power. Regarding the analyses, in addition to the load reduction, the power factor and the demand response location are among other parameters to which the network operator should pay attention while operating and calculating ARDRM.

C. Results of locating the compensator

In this section, based on the proposed model, reducing or removing the DRM is done under different scenarios. We used the simple branch and bound (SBB), which is a tool in GAMS and highly capable of solving MNL P problems, to solve the model. To investigate the impact of the reactive power compensation sources, the intended scenario was chosen as an industrial load on a winter day. The static parameters for the load's active and reactive power were shown in Table I.

OLTC and VR. Also, the STATCOMs location by considering two constraints of their number and an upper limit of injection was done. The mismatch coefficient parameters in equation (7) are $\eta=\mu=1$. The simulation results are shown in Table III. For the non-compensation state and with $N_i=0$, ADRM and RDRM values are 5.59% and 13.89%. Corresponding to the achieved results in all of the possible scenarios, the DRM values of both active and reactive powers decrease.

It can be inferred from Table III that if the number and capacity of STATCOM increases, ADRM and RDRM decrease. The decrease in RDRM is much higher than the decrease in ADRM. Because the sensitivity ratio of the reactive demand response mismatch is higher than that of demand response mismatch for industrial loads. Transformers' tap coordination with STATCOM can also decrease the DRM considerably. The largest decrease is related to two STATCOMs with a capacity of 5 MVar. In this state, ADRM and RDRM are equal to 1.24% and 2.55% respectively. The compensation by two STATCOMs with a capacity of 2.5 MVar will be more optimal than the compensation by one STATCOM with a capacity of 5 MVar.

Additionally, according to MINLP solving problem cannot claim that the results are globally optimal, but the results show the effectiveness of proposed method for removing mismatches in distribution networks.

V. CONCLUSIONS

This paper investigated reactive demand response mismatch, in addition to the active demand response mismatch, which is a new concept in demand response programs in the smart grid. DRM was dependent on several factors such as the network structure, the demand response location, the load's power factors, the percentage of load reduction, and the type of load modeling (regarding different static parameters, which are dependent on the season and the time of the day). To solve the DRM problem, a reactive power control is employed through locating STATCOM as well as coordinating transformers' tap settings.

REFERENCES

- [1] J. Momoh, *Smart grid: Fundamentals of design and analysis*: John Wiley & Sons, 2012.

- [2] D. Hurley, P. Peterson, and M. Whited, "Demand response as a power system resource," *Regulatory Assistance Project: Montpelier, VT, USA*, 2013.
- [3] W. Shi, N. Li, X. Xie, C.-C. Chu, and R. Gadh, "Optimal residential demand response in distribution networks," *IEEE Journal on Selected Areas in Communications*, vol. 32, pp. 1441-1450, 2014.
- [4] H. Mohsenian-Rad and A. Davoudi, "Optimal demand response in DC distribution networks," in *IEEE SmartGridComm*, pp. 564-569, 2013.
- [5] C. Vivekananthan, Y. Mishra, G. Ledwich, and F. Li, "Demand response for residential appliances via customer reward scheme," *IEEE Transactions on Smart Grid*, vol. 5, pp. 809-820, 2014.
- [6] K. Christakou, D.-C. Tomozei, M. Bahramipanah, J.-Y. Le Boudec, and M. Paolone, "Primary voltage control in active distribution networks via broadcast signals: The case of distributed storage," *IEEE Transactions on Smart Grid*, vol. 5, pp. 2314-2325, 2014.
- [7] K. Christakou, D.-C. Tomozei, J.-Y. Le Boudec, and M. Paolone, "GECN: Primary voltage control for active distribution networks via real-time demand-response," *IEEE Transactions on Smart Grid*, vol. 5, pp. 622-631, 2014.
- [8] V. Moghadam, R. Mohammad, R. T. Ma, and R. Zhang, "Distributed frequency control in smart grids via randomized demand response," *IEEE Transactions on Smart Grid*, vol. 5, pp. 2798-2809, 2014.
- [9] S. A. Pourmousavi and M. H. Nehrir, "Real-time central demand response for primary frequency regulation in microgrids," *IEEE Transactions on Smart Grid*, vol. 3, pp. 1988-1996, 2012.
- [10] F. A. Rahiman, H. H. Zeineldin, V. Khadkikar, S. W. Kennedy, and V. R. Pandi, "Demand response mismatch : Concept, impact analysis and solution," *IEEE Transactions on Smart Grid*, vol. 5, pp. 1734-1743, 2014.
- [11] N. G. Hingorani and L. Gyugyi, *Understanding FACTS: concepts and technology of flexible AC transmission systems*: Wiley-IEEE, 2000.
- [12] W. Price, S. Casper, C. Nwankpa, R. Bradish, H. Chiang, C. Concordia, et al., "Bibliography on load models for power flow and dynamic performance simulation," *IEEE Power Engineering Review*, vol. 15, p. 70, 1995.