

# Comparative Analysis of Flame Propagation in Hydrogen Deflagrations

Elena Vasquez, Liam O'Connor

University of California, San Diego, USA

## ABSTRACT

This paper presents a comparison between two numerical approaches for the modelling of vented hydrogen deflagrations: computation fluid dynamics (CFD) simulations and empirical engineering models (EMs). The study is a part of the project 'Improving hydrogen safety for energy applications through pre-normative research on vented deflagrations' (HySEA). Data from experiments conducted as part of the HySEA project are used to evaluate the CFD results and predictions from EMs. The HySEA project focusses on vented hydrogen deflagrations in containers and smaller enclosures with internal congestion representative of hydrogen applications in industry. The CFD tool FLACSHydrogen is used to simulate vented hydrogen deflagrations in 20-foot ISO containers with various obstacle configurations, and EMs for vented deflagrations are applied to the same scenarios. For the Phase 1 tests, both EM and FLACS-Hydrogen predict the maximum overpressure variation for the various configurations considered with reasonable accuracy. In general, both the EMs and the CFD tools tend to overpredict the maximum overpressures measured in the experiments. The HySEA project receives funding from the Fuel Cells and Hydrogen Joint Undertaking (FCH JU) under grant agreement No. 671461.

## 1. INTRODUCTION

Fires and explosions represent a significant hazard for hydrogen installations, and specific measures are generally required for reducing the risk to a tolerable level [1]. Explosion venting is a frequently used measure for reducing the consequences of hydrogen deflagrations in confined systems. However, the empirical correlations for designing venting devices that are provided in international standards, such as EN 14994 [5] and NFPA 68 [6], are derived from experiments performed with empty vessels and often at smaller spatial scales than the actual industrial applications. This limits their applicability with respect to industrial scenarios. The main objective of the project "Improving Hydrogen Safety for Energy Applications through pre-normative research on vented deflagrations" (HySEA) is to provide recommendations for how the predictive capabilities of EMs in international standards for vented hydrogen deflagrations can be improved. Details of the HySEA project can be found in the project website: [www.hysea.eu](http://www.hysea.eu). The HySEA project includes systematic efforts to validate and improve EMs (WP1), experimental campaigns to study vented hydrogen deflagrations in various configurations and spatial scales (WP2), and computational fluid dynamics (CFD) and finite element (FE) modelling to improve and validate commercial as well as open-source software tools (WP3).

The main objective of this paper is to compare the predictive capabilities of EMs and the CFD tool FLACS-Hydrogen with respect to estimating the maximum reduced explosion pressure  $P_{red,max}$  in vented hydrogen deflagrations, with particular emphasis on enclosures for industrial applications. Hence, the assessment of numerical models is limited to the experimental results from Phase 1 of the experimental campaign in 20-foot ISO containers in the HySEA project [2-4]. The CFD predictions are obtained using the commercial CFD tool FLACS-Hydrogen from Gexcon. The engineering models considered in this study include the international standards EN 14994 [5] and NFPA 68 [6-7], and formulations proposed by Molkov [8], Molkov and Bragin [9] (referred to as 'Molkov 2013') and Bauwens *et al.* [10-12].

Section 2 describes the experimental campaign, the CFD tool FLACS-Hydrogen and the EMs used. Section 3 compares results from CFD simulations and predictions from EMs for the experiments conducted during Phase 1 of the HySEA 20-foot container tests. Finally, Section 4 concludes the study with discussion on the performance of the numerical models and outlook for further work.

## 2. EXPERIMENTS AND MODELLING

### 2.1. Experiments

The HySEA project includes an experimental campaign with vented hydrogen deflagrations in 20-foot ISO containers. This paper uses results from Phase 1, that focused on homogeneous hydrogen-air

mixtures [2-4]. The second experimental campaign will involve inhomogeneous mixtures generated by steady-state or transient releases, with or without initial turbulence in the enclosure.

Phase 1 of the experimental campaign in 20-foot ISO containers focused on vented explosions in homogeneous hydrogen-air mixtures. The test program included 34 experiments: 14 tests with deflagrations vented through the doors of the containers and 20 tests vented through openings in the roof. The parameters investigated include mixture composition, vent area, effect of obstacles inside the enclosure, and variation of the static opening pressure and weight of the vent covers. Tables 1 and 2 summarise the test configurations for experiments with venting through the container doors and venting through the roof of the container, respectively. Figure 1 (a) illustrates the nomenclature used for describing the experimental configurations. Tests vented through the container doors used ignition position A, and tests vented through the roof used position B. Two obstacles, either a bottle basket (B) or a pipe rack (P) could be fixed in locations 1, 2 or 3. A steel frame was placed on the floor of the container to protect the instrumentation and support the obstacles. Figure 1 (b) illustrates a configuration with the pipe rack obstacle in position 1 (P1) and the bottle basket obstacle in position 3 (B3), referred to as configuration P1B3. The experimental campaign is described in detail elsewhere [2-4].

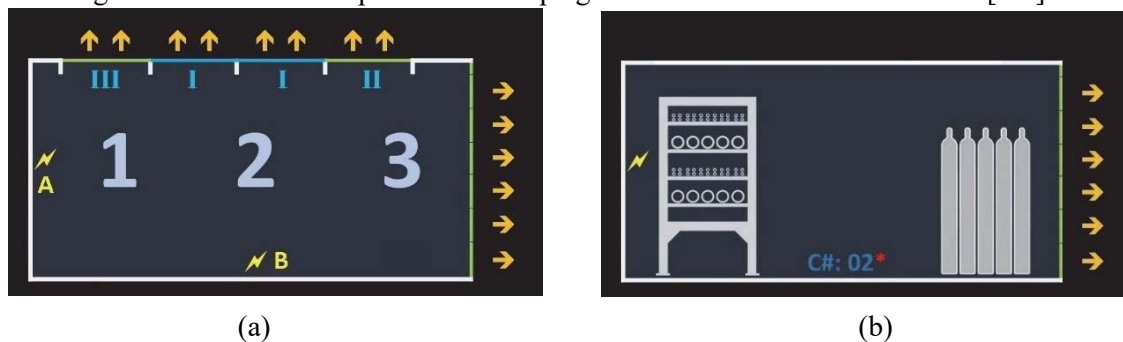

Figure 1: Nomenclature and example of geometry configurations for container experiments.

## 2.2. FLACS-Hydrogen

This study includes two versions of the CFD tool FLACS-Hydrogen for simulating vented hydrogen deflagrations: the standard commercial version FLACS v10.6 and an in-house R&D version that will be referred to as FLACS-beta. The CFD solver in FLACS is a 3D finite volume solver based on a singleblock structured Cartesian mesh, fully compressible, using the SIMPLE pressure correction algorithm. The Flacs solver includes a first order backward Euler temporal scheme with time-stepping controlled by Courant numbers based on local velocity (CFLV) and the speed of sound (CFLC), second order blended Kappa scheme for spatial discretisation with weighting between second order upwind and second order central difference, second order diffusion scheme, standard  $k-\bar{I}$  turbulence model [13] with additional turbulence generation terms for sub-grid scale objects, combustion model based on the flamelet approach, with a turbulent burning velocity correlation proposed by Bray [14] and the beta flame model [15]. FLACS belongs to the porosity/distributed resistance (PDR) family of CFD solvers [16-17], and empirical approximation of selected model components enables a significant increase in computational speeds for simulations that involve large-scale complex geometries. In addition to FLACS v10.6, this study includes results obtained with an in-house R&D version of FLACS that uses the kskL turbulence model from Menter *et al.* [18] in conjunction with the turbulent burning velocity correlation proposed by Bradley *et al.* [19], and systematic parametric optimisation [20].

Extensive verification, calibration and validation of FLACS, for a wide range of release, dispersion, fire and explosion scenarios, including scenarios involving vented hydrogen deflagrations, makes FLACSHydrogen particularly relevant for the HySEA project.

## 2.3. Engineering models

Engineering models are usually based on empirical correlations, and the range of applicability is limited by the available experimental data. The two most widely used EMs for design of venting devices are NFPA 68 [6-7] and EN 14994 [5]. However, neither is considered suitable for hydrogen applications [21-22]. NFPA 68 [7] accounts for the presence of internal obstacles inside the container through a parameter representing the surface area of the obstacles. The correlations in EN 14994 do not account for internal obstacles, but is more flexible with respect to type of venting device. The EN 14994 model predictions in this study were obtained from the compact enclosures correlation which applies the gas

explosion constant  $K_G$ . The model is limited to  $K_G < 550 \text{ bar m s}^{-1}$ , which allows for estimates of the effect of changes in the hydrogen concentration for lean mixtures of hydrogen in air.

Several other empirical correlations have been proposed [e.g. 21-22]. In addition to NFPA 68 and EN 14994, this study considers the EMs proposed by Molkov [8], Molkov and Bragin [9] (generally referred to as ‘Molkov 2013’) and FM-Global [10-12]. Both the FM-Global correlations and Molkov 2013 consider various physical properties, and have been calibrated with relatively extensive experimental datasets [9].

### 3. RESULTS

The CFD and engineering model predictions are compared with experimental results obtained from Phase 1 of the experimental campaign with 20-foot ISO containers in the HySEA project. The maximum reduced overpressure is the most frequently used variable for vented deflagration studies, and  $P_{\text{red, max}}$  will therefore be used as the main assessment criteria when evaluating the numerical models. The CFD simulations provide 3D pressure data that facilitate a more comprehensive comparison with the experimental results. The EMs will typically only provide estimates for  $P_{\text{red, max}}$  for the vented enclosure.

#### 3.1. Experiments with venting through the doors

Table 1 summarises the test conditions and results for the first 14 tests of the Phase 1 experiments, with venting through the container doors. Figure 2 shows a typical geometry model from FLACS. Except from test 09, where the doors were initially closed and locked, the doors were fully open and the vent opening was covered with a 0.2 mm 99 % polyethylene film, specific weight  $0.185 \text{ kg m}^{-2}$ , held in place by wooden boards and clamps [2-4]. Figure 3 presents scatter plots with model predictions vs. experimental data. The green dotted lines indicate  $\pm 30 \%$  error bars, and the blue dotted lines indicate FAC2 (factor-two) error bars according to the relation:

Table 1: Summary of the 14 experiments with venting through the container doors.

Configuration	Test no.	Vent area in m <sup>2</sup>	Hydrogen concentration in vol. %	Experiment [2-4]	FM Global model [10-12]	Molkov (2011) [8]	Molkov 2013 (Best fit) [9]	Molkov 2013 (Conservative) [9]	NFPA 68 (2013) [7]	EN-14994 (2007) [5]	
											Maximum reduced overpressure in bar
Frame only (FO), doors open (O)	1	5.64	15	0.040	0.031	0.159	0.021	0.053	0.024	0.21	
	2	5.64	15	0.047	0.031	0.159	0.021	0.053	0.024	0.21	
	5	5.64	15	0.039	0.031	0.159	0.021	0.053	0.024	0.21	
Bottle basket (B1), doors open (O)	3	5.64	15	0.077	0.052	0.159	0.104	0.272	0.024	0.21	
	4	5.64	15	0.064	0.052	0.159	0.104	0.272	0.024	0.21	
	6	5.64	15	0.045	0.052	0.159	0.104	0.272	0.024	0.21	
	10	5.64	18	0.130	0.234	0.62	0.277	0.723	0.143	0.23	
Bottle basket (B1), doors closed (C)	7	5.64	21	0.190	0.679	1.349	0.526	1.371	NA	0.27	
	8	5.64	24	0.390	1.43	1.813	0.716	1.868	1.149	0.31	
	09*	0	24	1.447	Not considered						
Pipe rack (P1), doors open (O)	11	5.64	15	0.050	0.061	0.159	0.104	0.272	0.024	0.21	
	12	5.64	18	0.120	0.271	0.62	0.277	0.723	0.143	0.23	
	13	5.64	21	0.279	0.795	1.349	0.526	1.371	NA	0.27	
Pipe rack and bottle basket (P1 B3), doors open (O)	14*	5.64	21	0.939	1.043	1.349	0.526	1.371	NA	0.27	

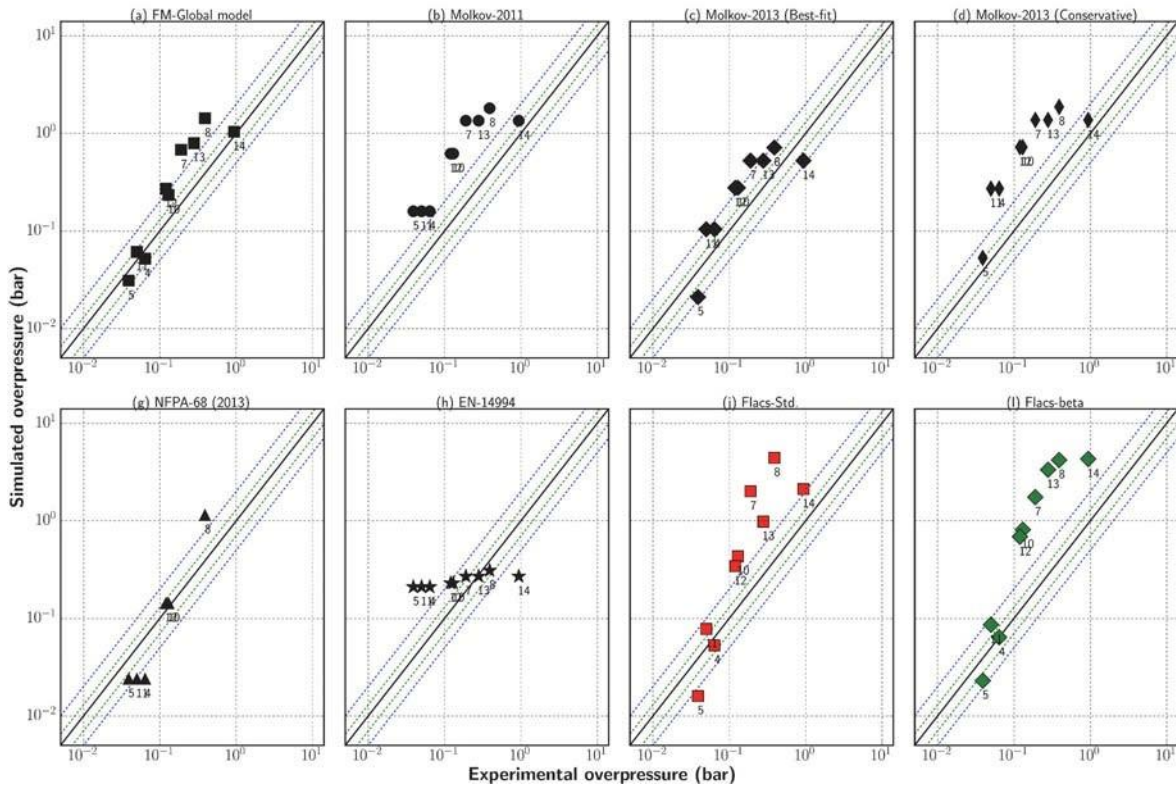
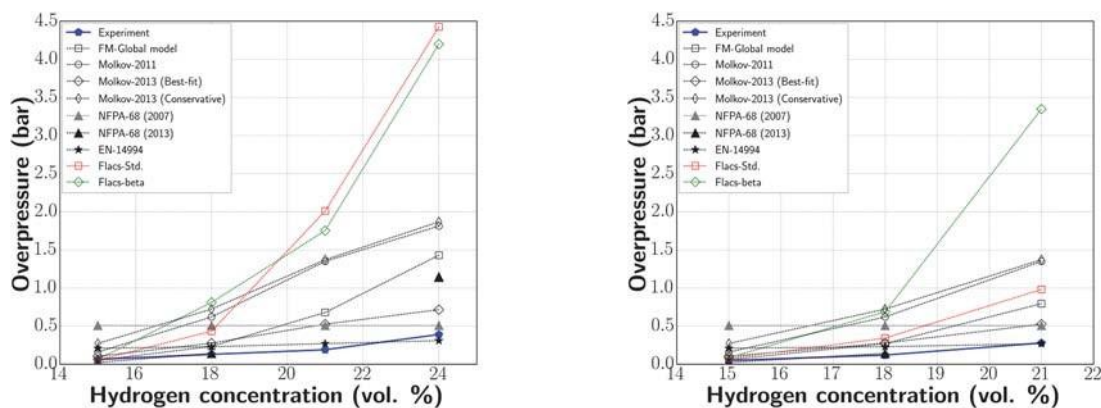

Figure 3: Scatter plot of max. overpressures for the experiments with venting through the door. (---: ±30%; ---: FAC2)

Most of EMs show reasonable agreement with the experiments, and capture the effect of varying hydrogen concentration. There is a general tendency towards over-prediction. The predictions obtained with EN 14994 are sensitive to changes in the hydrogen concentration, and the model does not account for the effect of internal congestion. Overall, the FM-Global model [10-12] and the Molkov 2013 bestfit correlation [9] are on best agreement with these experiments. The results obtained with the two FLACS versions show similar trends, but tend to over-predict  $P_{red,max}$  for fuel concentrations exceeding about 20 vol.% hydrogen in air.

Figure 4 summarizes the results for two configurations: bottle basket in inner position (B1) and pipe rack in inner position (P1).



(a): Tests 3, 10, 7 and 8 (B1 configuration)

(b): Tests 11, 12 and 13 (P1 configuration)

Figure 4: Variation of  $P_{red,max}$  with hydrogen concentration for tests with venting through the doors.



As observed in the scatter plots (Figure 3), the EN 14994 predictions show minimal variation in the overpressure with increasing hydrogen concentration. The 2007 edition of NFPA 68 is also insensitive to variations in hydrogen concentration. The other EMs show agreeable trend, but tend to over-predict  $P_{red, max}$ . The 2013 edition of NFPA 68 did not converge for 21 vol.% hydrogen.

Both the FLACS versions overpredict  $P_{red, max}$  for the more reactive mixtures (21 and 24 vol.%), and are more sensitive to changes in hydrogen concentration. The EMs as well as FLACS perform best for the tests with 15 vol. % hydrogen. Some EMs do not account for the effect of internal congestion. The Molkov 2013 correlation [9] accounts for the presence of obstacles inside the container through a flame wrinkling enhancement factor. However, this factor does not vary with changes to the geometry. The 2013 edition of NFPA 68 [7] accounts for the effects of internal obstacles by considering the surface area of the obstacles. For these specific tests, the values of  $P_{red, max}$  do not vary significantly between configurations B1 and P1, although there is a tendency towards higher overpressures for tests with the pipe rack and more reactive mixtures [2-4]. In fact, the test with P1 and 24 vol.% hydrogen was not performed in Phase 1 because it was not clear whether the container would survive the test.

### 3.2. Experiments with venting through the roof

Table 2 summarises the test conditions and results for the 20 tests from the Phase 1 experimental campaign in 20-foot containers with venting through the container roof. Figure 5 shows a typical geometry model from FLACS. The eight vent openings, each with dimension 1 m × 1 m, could be fitted with a blind flange (to reduce the effective vent area), commercial vent panels from Fike (single-sheet bulged rupture panels with static activation pressure 0.1 bar), or 0.2 mm 99 % polyethylene film (specific weight 0.185 kg m<sup>-2</sup>, and perforated along the edges). The container doors were closed in these tests.

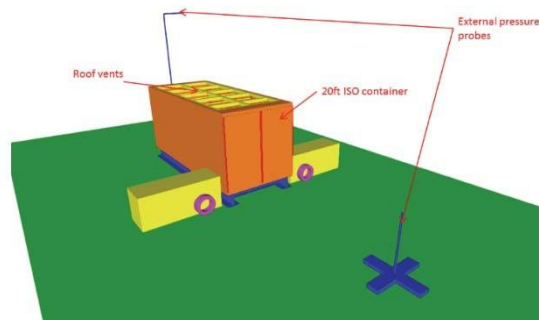

Figure 5: Geometry model for tests with venting through the container roof.

Figure 6 presents the scatter plots with model predictions vs. experimental data for the tests with venting through the roof. The Molkov 2013 and EN 14994 correlations are not applicable to test 34, with hydrogen concentration 42 vol.%). The estimates from FM-Global, Molkov-2011 and the 2013 edition of NFPA 68 tend to overpredict  $P_{red, max}$ , whereas Molkov 2013 ‘best fit’ under-predicts. The Molkov 2013 ‘conservative’ model is in good agreement with experimental data. EN 14994 and the Molkov 2013 ‘conservative’ correlation are in best agreement with the experiments for the tests with venting through the roof configuration. The results obtained with FLACS-Hydrogen v10.6 overpredict  $P_{red, max}$  for the tests with venting through the roof, whereas the results obtained with the in-house beta version are in better agreement with the experimental results.

Figure 7, Figure 8 and Figure 9 plot  $P_{red, max}$  as function of vent size for different congestion configurations and hydrogen concentrations.

Table 2: Summary of the 20 experiments with venting through the container roof.

Configuration	Test no.	Vent area in m <sup>2</sup>	Hydrogen concentration in vol. %	Experiment [2-4]	FM Global model [10-12]	Molkov (2011) [8]	Molkov 2013 (Best fit) [9]	Molkov 2013 (Conservative) [9]	NFPA 68 (2013) [7]	EN-14994 (2007) [5]
Frame only (FO), perforated plastic film (O)	25	4.0	21	0.146	0.435	1.691	0.16	0.417	0.771	0.48
	21	6.0	21	0.12	0.315	1.131	0.095	0.246	0.382	0.24
	16	8.0	21	0.19	0.252	0.657	0.065	0.17	0.212	0.14
Pipe rack (P2), perforated plastic film (O)	24	4.0	21	0.15	0.865	1.691	0.16	0.417	0.771	0.48
	22	6.0	21	0.142	0.586	1.131	0.095	0.246	0.382	0.24
	17	8.0	21	0.124	0.455	0.657	0.065	0.17	0.212	0.14
Pipe rack (P2), perforated plastic film (O)	34*	8.0	42	1.076	2.577	2.003	NA	NA	1.648	NA
	29	4.0	24	0.414	1.845	2.133	0.218	0.569	1.576	0.54
	23	6.0	24	0.168	1.229	1.608	0.129	0.336	NA	0.27
Frame only (FO), commercial vent panels (P)	19	8.0	24	0.136	0.944	1.211	0.089	0.231	NA	0.16
	32	4.0	21	0.214	0.435	2.107	0.176	0.458	0.876	0.48
	26	6.0	21	0.245	0.315	1.394	0.104	0.271	0.385	0.24
Pipe rack (P2), commercial vent panels (P)	15	8.0	21	0.191	0.252	0.794	0.071	0.186	0.214	0.14
	33	4.0	21	0.261	0.865	2.107	0.176	0.458	0.876	0.48
	27	6.0	21	0.301	0.586	1.394	0.104	0.271	0.385	0.24
Pipe rack (P2), commercial vent panels (P)	31	6.0	21	0.301	0.586	1.394	0.104	0.271	0.385	0.24
	18	8.0	21	0.234	0.455	0.794	0.071	0.186	0.214	0.14
	30	8.0	21	0.234	0.455	0.794	0.071	0.186	0.214	0.14
Pipe rack (P2), commercial vent panels (P)	28*	6.0	24	0.729	1.229	2.002	0.142	0.369	0.994	0.27
	20*	8.0	24	0.334	0.944	1.495	0.097	0.254	0.581	0.16

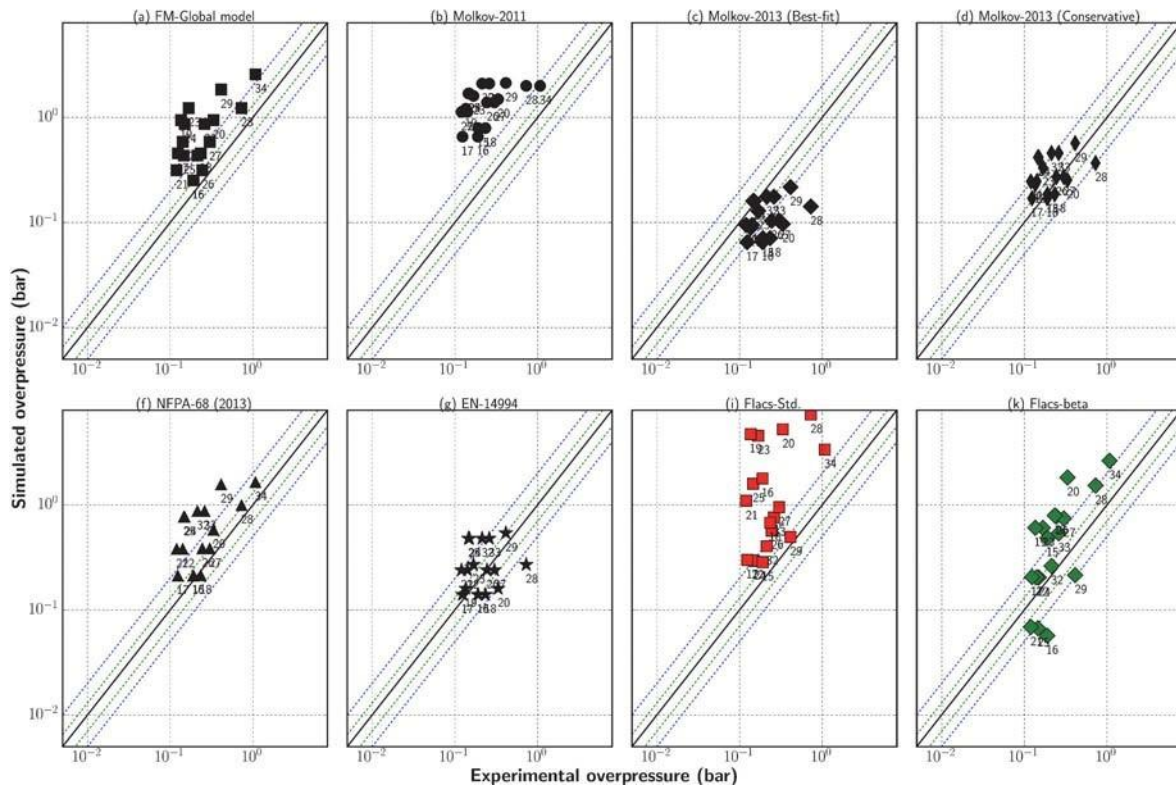

Figure 6: Scatter plot of max. overpressures for the experiments with venting through the roof.

Figure 7 show the  $P_{red, max}$  predictions as function of vent area, for tests with frame only (FO), 21 vol.% hydrogen and vent openings covered by either perforated plastic film (a) or commercial vent panels (b). The EMs predict a monotonic decrease in  $P_{red, max}$  with increasing vent area. The experiments are less conclusive – the slight increase in  $P_{red, max}$  when the vent area increases from 6 m<sup>2</sup> to 8 m<sup>2</sup>, for the tests with plastic film, is within the experimental uncertainty [2-4]. Both versions of FLACS-Hydrogen predict a monotonic decrease in the overpressure for the tests with plastic film, and a maximum for 6 the m<sup>2</sup> vent with commercial vent panels. FLACS beta version predictions are less sensitive to changes in the vent size than the standard version. Among the EMs, the Molkov 2013 ‘best fit’ correlation show the closest agreement with the experiments. For CFD tools and EMs, the predictions tend to of 8 m<sup>2</sup>, the EM and CFD predictions show the best agreement with the experimental  $P_{red, max}$ .

Figure 8 show  $P_{red, max}$  predictions as function of vent area, for tests with the pipe rack obstacle in centre position (P2), 21 vol.% hydrogen and vent openings covered by either perforated plastic film (a) or commercial vent panels (b). Both versions of FLACS-hydrogen capture the observed trend in  $P_{red, max}$ . The EMs predict a monotonic decrease in the overpressures with increasing vent area, and the predictions by the Molkov 2013 best-fit correlation are in best agreement with the experimental results.

Figure 9 show the  $P_{red, max}$  predictions as function of vent area, for tests with the pipe rack obstacle in centre position (P2), 24 vol.% hydrogen and vent openings covered by either perforated plastic film (a) or commercial vent panels (b). All the EMs capture the trend observed in the experiments. FLACS v10.6 over-predict the observed values for  $P_{red, max}$  significantly for the larger vent areas. Further analysis is required for understanding these results. The predictions by the beta version of FLACS are in better agreement with experimental results.

As a general observation, the results for vented explosion pressures obtained with CFD tools are very sensitive to modest variations in initial and boundary conditions. This observation is consistent with the results from the first HySEA blind-prediction study [23].

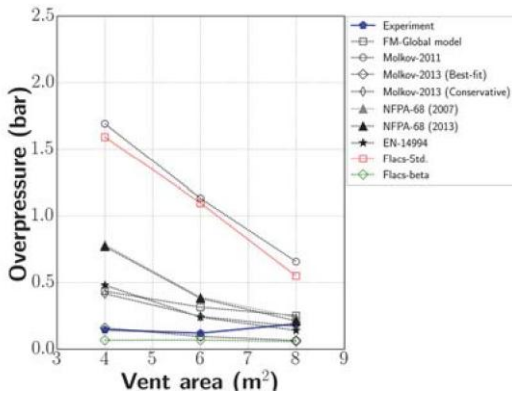

(a): Tests 25, 21 and 16 with plastic film.

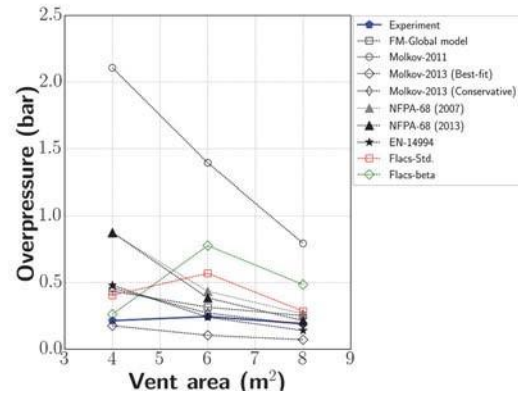

(b): Tests 32, 26 and 15 with vent panels.

Figure 7:  $P_{red, max}$  for frame only (FO), 21 vol.% hydrogen in air, and venting through the roof.

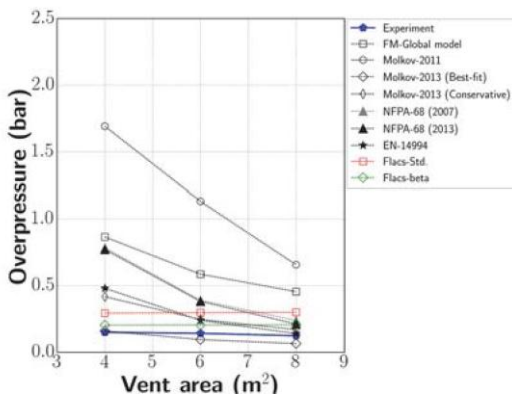

(a): Tests 24, 22 and 17 with plastic film.

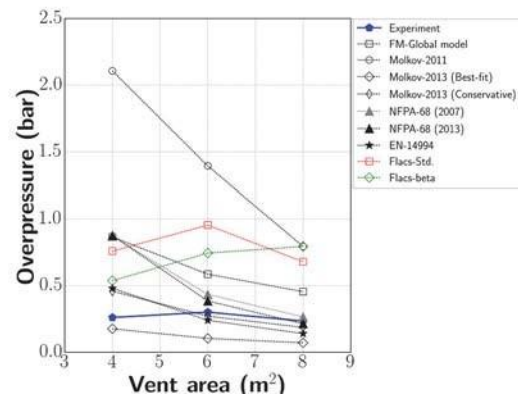

(b): Tests 27, 31 and 18 with vent panels.

Figure 8:  $P_{red, max}$  for pipe rack in centre position (P2), 21 vol.% hydrogen in air, and venting through the roof.

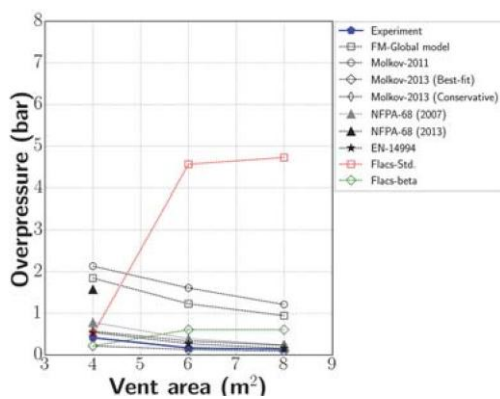

(a): Tests 29, 23 and 19 with plastic film.

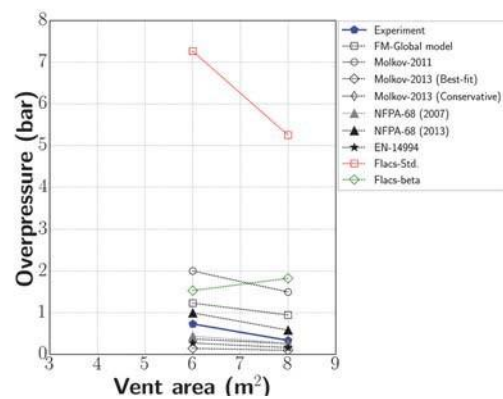

(b): Tests 28 and 20 with vent panels.

Figure 9:  $P_{red, max}$  for pipe rack in centre position (P2), 24 vol.% hydrogen in air, and venting through the roof.

#### 4. DISCUSSION AND OUTLOOK

It is common practice in industry to install electrolysers, refuelling stations, fuel cell backup systems and other equipment for hydrogen energy applications in containers or smaller enclosures. Fires and explosions represent a significant hazard for hydrogen installations, and specific measures are generally required for reducing the risk to a tolerable level [24]. Explosion venting is a frequently used measure for reducing the consequences of hydrogen deflagrations in confined systems. This paper compares the performance of selected engineering models (EMs) and two versions of the computational fluid dynamics (CFD) simulator FLACS-Hydrogen, with respect to predicting the maximum reduced explosion pressure  $P_{\text{red, max}}$  for a set of vented hydrogen deflagration experiments performed in 20-foot ISO containers [2-4].

The EMs are typically empirical correlations derived from experimental data, and hence much less computationally expensive than the CFD tools. However, their range of applicability is limited by the physical conditions covered by the experiments used to derive the empirical correlations. For instance, the 2007 edition of NFPA 68 [6] and EN 14994 [5] do not account for the effect of congestion, EN 14994 assumes a static activation pressure for the vent panels of 0.1 bar and can only be applied to fuel-air mixtures with explosion constant  $K_G$  less than  $550 \text{ bar m s}^{-1}$ , most EMs do not account for the effect of initial turbulence and inhomogeneous mixtures, etc. The models from FM Global and Molkov consider a larger range of physical effects, compared to EN 14994, and seem to produce more consistent results. The trade-off is the complexity of the calculations, which can be an important factor for correlations intended for use in international standards.

The Molkov 2013 best-fit correlation shows good agreement with the experiments, both the venting through the door and venting through the roof. The EMs considered are less sensitive to the effect of variations in congestion inside the container, and would not capture the increase in  $P_{\text{red, max}}$  from tests 13 (0.28 bar) to test 14 (0.94 bar) without further assumptions (e.g. a reduction in the effective vent area due to the presence of the bottle basket near the vent opening). Overall, the Molkov 2013 model [9] seems to produce the most consistent results. The best-fit version of this model shows good agreement with the experimental observations for venting through the doors, and under-predicts the  $P_{\text{red, max}}$  for venting through the roof. The conservative correlation from the Molkov 2013 model provides reasonable predictions for all the scenarios studied.

For the tests with venting through the doors, both versions of the FLACS solver predict similar trends. For the tests with venting through the roof, the predictions by the beta version are more consistent, compared with the standard version. Overall, the results from CFD simulations of vented hydrogen deflagrations appear to be overly sensitive to modest variation in the initial and boundary conditions, and further work is required to improve the predictive capabilities. This observation is consistent with the results from the first HySEA blind-prediction study [23]. Systematic parameter optimization represents a promising option for improving the performance of CFD tools and other models that include numerous empirical variables [20]. Nevertheless, the potential for detailed geometry modelling and more realistic simulation of relevant physical phenomena, including turbulent reacting flow, suggest that CFD simulations will remain an important tool for estimating the consequences of vented explosions.

Phase 2 of the experimental campaign in 20-foot ISO containers in the HySEA project will consider vented deflagrations with inhomogeneous gas clouds. This will increase the complexity of the modelling. However, it is important to determine whether an explosion in a cloud with a significant concentration gradient can produce significantly higher overpressures, compared to an explosion in a lean but homogeneous hydrogen-air mixture (for the same total mass of fuel).

One of the objectives of the HySEA project is to develop a modelling framework of hierarchical complexity, ranging from the empirical correlations used in engineering models to advanced CFD and finite element (FE) tools. The results presented in this paper represent an important step towards the envisaged modelling framework. Further work in the HySEA project will focus expanding the validation matrix for EMs as well as CFD tools, and providing best practices guidelines for users of the models.

## REFERENCES

1. Skjold, T., Siccama, D., Hisken, H., Brambilla, A., Middha, P., Groth, K.M. and LaFleur, A.C., 3D risk management for hydrogen installations, *International Journal of Hydrogen Energy*, 42, 2017, pp. 7721-7730.
2. Skjold, T., Lakshmipathy, S., van Wingerden, M., Hisken, H., Atanga, G., Olsen, K.L., Holme, M.N., Turøy, N.M., Mykleby, M. & van Wingerden, K., Experimental investigation of vented hydrogen deflagrations in containers - Phase 1, July 2017, Report HySEA-D2.04-2017, 314 pp.
3. Skjold, T., Hisken, H., Lakshmipathy, S., Atanga, G., van Wingerden, M., Olsen, K.L., Holme, M.N., Turøy, N.M., Mykleby, M & van Wingerden, K., Influence of congestion on vented hydrogen deflagrations in 20-foot ISO containers: homogeneous fuel-air mixtures, Twenty-Sixth International Colloquium on the Dynamics of Explosions and Reactive Systems (ICDERS), Boston, 30 July – 4 August 2017, 6 pp.
4. Skjold, T., Hisken, H., Lakshmipathy, S., Atanga, G, van Wingerden, M., Olsen, K.L., Holme, M.N., Turøy, N.M., Martin Mykleby, M., and van Wingerden, K., Vented hydrogen deflagrations in containers: effect of congestion and homogeneous mixtures, International Conference on Hydrogen Safety (ICHS), Hamburg, 11-13 September 2013, 13 pp.
5. EN 14994, Gas explosion venting protective systems, European Committee for Standardization (CEN), Brussels, February 2007, 27 pp.
6. NFPA 68, Standard on explosion protection by deflagration venting, 2007 edition, National Fire Protection Association,” NFPA, 1 Batterymarch Park, Quincy, Massachusetts, USA 02169-7471, 2007, 88 pp.
7. NFPA 68, Standard on explosion protection by deflagration venting, 2013 edition, National Fire Protection Association,” NFPA, 1 Batterymarch Park, Quincy, Massachusetts, USA 02169-7471, 2013, 83 pp.
8. Molkov, V., Primer: hydrogen deflagrations, Presentation Joint Summer School on Fuel Cell and Hydrogen Technology, 21-25 August 2011, Viterbo, Italy.
9. Molkov, V. and Bragin, M., Hydrogen–air deflagrations: vent sizing correlation for low-strength equipment and buildings, *International Journal of Hydrogen Energy*, 2015, 40: 1256-1266.
10. Bauwens, C.R., Chaffee, J. and Dorofeev, S.B., Effect of ignition location, vent size, and obstacles on vented explosion overpressures in propane-air mixtures, *Combustion Science and Technology*, 182, 2010, pp. 1915-1932.
11. Bauwens, C.R., Chao, J. and Dorofeev, S.B., Evaluation of a multi peak explosion vent sizing methodology, Ninth International Symposium on Hazard, Prevention and Mitigation of industrial Explosions (ISHPMIE), 22-27 July 2012, Krakow, Poland.
12. Chao, J., Bauwens, C.R. and Dorofeev, S.B., An analysis of peak overpressures in vented gaseous explosions, *Proceedings of the Combustion Institute*, 33, 2011, pp. 2367-2374.
13. Launder, B. E. and Spalding, D. B., The numerical computation of turbulent flows, *Computer Methods in Applied Mechanics and Engineering*, 3, 1974, pp. 269-289.
14. Bray, K.N.C., Studies of the turbulent burning velocity, *Proceedings: Mathematical and Physical Sciences*, 431, 1990, pp. 315-335.
15. Arntzen, B., Modelling of the turbulence and combustion for simulation of gas explosions in complex geometries,” PhD Thesis, 1998, Department of Energy and Process Engineering, Norwegian University of Science and Technology, Norway.
16. Patankar S.V. and Spalding, D.B., A calculation procedure for the transient and steady-state behavior of shell-and-tube heat exchangers,” in Heat exchangers: Design and theory sourcebook, 1974, McGraw-Hill, New York.

17. Hjertager, B., Three-dimensional modeling of flow, heat transfer, and combustion, in Handbook of heat and mass transfer, 1986, Guld Publishing, Houston.
18. Menter, F. Egorov, Y. and Rusch, D, Steady and unsteady flow modelling using the  $k\text{-}\epsilon\text{-}kL$  model, *Turbulence, Heat, and Mass Transfer*, 5, 2005, pp. 403-406.
19. Bradley, D., Lawes, M., Liu, K. & Mansour, M., Measurements and correlations of turbulent burning velocities over wide ranges of fuels and elevated pressures, *Proceedings of the Combustion Institute*, 34, 2013, pp. 1519-1526.
20. Braatz, A.-L., Hisken, H., and Rückmann, J., Surrogate-based optimization of model parameters for the improved modelling of industrial-scale gas explosions, Fifth International Conference on Engineering Optimization (EngOpt 2016), 19–23 June 2016, Iguassu Falls, Brazil.
21. Sustek, J. and Janovsky, B., Comparison of empirical and semi-empirical equations for vented gas explosion with experimental data, *Journal of Loss Prevention in the Process Industries*, 26, 2013, pp. 1549-1557.
22. Jallais, S. and Kudriakov, S., An inter-comparison exercise on engineering models capabilities to simulate hydrogen vented explosions, *ICHS*, Brussels, 9-13 September 2013, 13 pp.

23. Skjold, T., Hisken, H., Lakshmiathy, S., Atanga, G., Carcassi, M., Schiavetti, M., Stewart, J.R., Newton, A., Hoyes, J.R., Toliás, I.C., Venetsanos, A.G., Hansen, O.R., Geng, J., Huser, A., Helland, S., Jambut, R., Ren, K., Kotchourko, A., Jordan, T., Daubech, J., Lecocq, G., Hanssen, A.G., Kumar, C., Krümenacker, L., Jallais, S., Miller, D. and Bauwens, C.R., Blind prediction: estimating the consequence of vented hydrogen deflagrations for homogeneous mixtures in 20-foot ISO containers, International Conference on Hydrogen Safety (ICHS), Hamburg, 11-13 September 2013, 14 pp.