

# Hybrid Predictive Energy Management of Integrated Power Systems

Eva Rodriguez, Leon Kirsch

*University of Technology Berlin, Germany, and University of California Los Angeles, USA*

**Abstract:** In this paper, a new mechanism is proposed to apportion expected reserve costs between electricity market agents in the power system. The uncertainties of generation units, transmission lines, wind power generation and electrical loads are considered in this model. Hence, a Stochastic Unit Commitment (SUC) is used to apply the uncertainty of stochastic variables in the simultaneous energy and reserve market clearing problem. Moreover, electrical customers can participate in the electricity market based on their desired strategies. In this paper, a novel method is proposed to allocate reserve costs between GenCos, TransCos, electrical customers and wind farm owners. Consequently, market agents are responsible for paying a portion of the allocated expected reserve costs based on the economic metrics that are defined for the first time in this paper. Finally, two cases including a 3-bus test system and IEEE-RTS are utilized to illustrate the performance of the proposed mechanism to share the expected reserve costs.

**Index Terms—** Customer choice of reliability, Simultaneous market clearing, Stochastic programming, Reserve cost allocation, Wind power integrating.

## 1. Introduction

### 1.1. Aims and motivation

Restructuring in the power systems provides more freedom for different agents to participate in the Electricity Markets (EMs). Electrical consumers are one type of the market agents that can behave strategically based on their aims in the EM [1-2]. Although some of the consumers compete in the EM to maximize their economic profits [2], providing their required electricity demands with high level of reliability is the main concern of other electrical consumers [3]. In other words, the electrical consumer prefers to disregard or reduce its required electrical demand to achieve more economic profit, if it competes

in the EM based on the economic view. However, there is a group of consumers that are willing to lose economically while their desired electrical load is provided.

In the restructured power systems, in addition to the energy, other services are defined to supply the different system requirements, these are called Ancillary Services (ASs) [3]. Operating Reserves (ORs) are one kind of ASs that play an important role in providing standard reliability level of the power system especially when the Independent System Operator (ISO) is faced with contingency events or probability electricity production due to the renewable energies such as wind energy. Besides, the strategic behavior of

the electrical customers can affect positively or negatively on ISO's decisions. If these effects are negative, they can increase the system operating costs. Moreover, uncertainty in generation, transmission and electrical energy consumption causes an increase in the system's operating costs such as reserve cost. This uncertainty (e.g. uncertainty of generation, transmission and electrical load) in the power system makes the ISO unable to make decisions deterministically. Therefore, stochastic decision-making is needed to determine energy and reserve requirement in the stochastic power system.

### *1.2. Literature review*

In the literature, different works present new methods to solve the Unit Commitment (UC) and MarketClearing (MC) problems to achieve ORs and reserve costs under uncertainty of the power grid and wind power generation. In [4], Transmission Constrained Unit Commitment (TCUC) has been solved by a hybrid approach combined of stochastic and interval optimizations considering the net load uncertainty. In [5], an Improved Interval (II) method has been used to solve the TCUC problem under uncertainty of wind power generation. Besides, the computational burden and total operating costs have been compared in many different cases and the UC problem has been solved by Stochastic Programming (SP), Robust Optimization (RO), interval and II methods in [5]. In [6], another probabilistic method has been used to determine the operating reserve based on cost-benefit analysis that Interval Optimization (IO) method is used to model the uncertainty of wind power in the UC problem. In [7], the UC problem has been solved by reducing the operating reserve through wind power generation and in this way minimizing the operating costs. Besides, a parameter, deration rate, has been defined to directly influence the wind power output of the wind farm and the uncertainty of wind power generation.

In [8], SP has been used to enhance the performance of obtaining the requirement reserve to provide the reliability level in the Security-Constrained Unit Commitment (SCUC) problem. In [9], the probabilistic method is utilized to model the wind power uncertainty by a Triangular Approximate Distribution (TAD) in the SCUC problem. In [10], the multi-period optimization model has been used to determine the Spinning Reserve (SR). Also, authors solved the UC problem in each scenario due to the different states of the electrical loads and power units' capacities. In [11], an evolutionary optimization algorithm has been utilized to solve the UC problem to minimize the operating costs and emission level and maximize the reliability level of the power system. In [12], the performance of SUC, robust UC and interval UC problems have been compared according to different short-term time resolutions. Moreover, the RO method has been applied to obtain operating reserves in [13] and [14]. In [13], Conditional Value-at-Risk (CVaR) has been applied to the proposed problem, and reserves have been scheduled based on the uncertainty of wind energy generation. In [14], net load uncertainty has been considered in the proposed decision-making problem. In [15],

obtaining the zonal reserve problem has been discussed under the uncertainty of stochastic generation of renewable energies, and the probabilistic and heuristic method has been stated in [15].

In [16], a probabilistic approach has been used to achieve the reserve under uncertainty of wind power generation, electrical demand, and power generation of conventional units. Besides, energy and reserve market are cleared independently, that the reserve market is cleared before energy market in [16]. In [17], the Transmission System Operator (TSO) is responsible for apportioning dynamic reserves in the power system. In [18], the convex optimization method has been applied to solve the simultaneous real-time MC problem considering the uncertainty of wind energy resources. In [19], the MC problem has been solved considering the Day-Ahead Market (DAM) and the Balancing Market (BM). In [20], a merit order has been defined to enhance the dispatching of the stochastic generations in the DAM. In [1] and [2], the stochastic complementarity model has been utilized to apply the optimal bidding strategy of consumers. Besides, the proposed models of [1-2] and [19-20] have been solved by bi-level programming. In [21], the networkconstraint AC unit commitment problem has been solved considering the uncertainty of wind power generation based on a two-stage SP and Benders' decomposition methods. In [22], a two-stage SP has been presented to consider the uncertainty of wind energy integration to dispatch energy and reserve in the power system. Reserves have been obtained by generating units and flexible loads to cover the uncertainty of wind power in the smart grid environment in [22].

In [23], a novel method has been proposed to obtain optimal bidding of operating reserves in the sequential market mechanism of the Spanish electricity market. The flexible Expected Energy Not Supplied (EENS) criteria and the load point reliability of customers are presented to manage the reserves of the power system, respectively in [24] and [25]. In [26], authors state the algorithm to apportion the reserve costs through market agents based on the desired reliability level of electrical consumers and well-being analysis. In [27], the Value Of Lost Load (VOLL) of DisCos has been applied to the decisions of System Operator (SO) based on DisCos' desired reliability levels. Furthermore, an approach has been expressed to determine the operating reserve and apportion the reserve costs between electrical customers and GenCos under uncertainty of wind power generation in [3]. In [28], a novel mechanism based on the decentralized approach has been introduced to share reserve costs between consumers, generating units and SO in the simultaneous energy and reserve MC problem. In [29], a new approach has been presented to apportion the costs due to the demand response based on local marginal price. Besides, a fairness index has been introduced to assess the performance of the proposed method in [29].

### *1.3. Contributions*

In the literature, different mechanisms that apportion reserve costs have been presented. However, their proposed methods have not followed this idea that the market's agent is responsible for paying a portion of the reserve costs who makes the need of reserve in the power system.

Additionally, different countries apply different mechanisms to allocate reserve costs. For instance, GenCos are responsible for paying the reserve costs in some electricity markets (e.g. Austria, Netherlands and Singapore) [35-37]. However, in Switzerland, according to the decision that has been made by the Swiss Federal Administrative Court on July 8, 2010, the reserve costs are not allocated to the GenCos that their power generation output is more than 50 MW [38]. Also, the demand-side participants, consumers or DisCos, have to pay the reserve costs in most of the electricity markets in the world [39]. On the other hand, in the UK electricity market, both GenCos and the electrical consumers are charged for reserve costs [40]. Furthermore, a successful implementation of the flexibility cost allocation method has been proposed in [41]. According to [41], the flexibility cost is allocated between California Independent System Operator (CAISO) and Western Energy Imbalance Market (EIM). This way, the apportioned flexibility cost to CAISO is allocated to electrical consumers and GenCos. However, the apportioned flexibility cost to the EIM is allocated to the EIM entity scheduling coordinator. The functioning of these mechanisms depends on the specific energy policies of each country which in turn rely on the country's infrastructure, industry and economy. Hence, it is not acceptable to apply a reserve cost allocation mechanism of one country to others without first evaluating and studying their electricity markets from all aspects. Some researchers state that paying the reserve costs by the electrical consumers is the fair method because reserves are prepared to maintain their required electricity demands. However, others believe that GenCos should be responsible for paying the reserve costs, because failures of their generating units cause to need the reserve. On the other hand, allocating the reserve costs to GenCos can impact negatively on the electrical customers too. Thus, GenCos increase their corresponding energy price to compensate their loss of reserve cost. For this reason, a strategy is needed to cover the reserve costs between electricity market players as fairly as possible.

In this paper, a new approach is proposed to apportion expected reserve costs between market agents through strategic behaviour of electrical customers and uncertainties of the power system. Wind power generation, electrical load and power grid (including generation units and transmission lines) are the sources of uncertainty in the proposed decision-making problem. Hence, an SUC is solved to model the simultaneous energy and reserve MC problem. Although electrical customers are responsible for the energy costs, the reserve costs are paid by GenCos, TransCos, wind farm owners and customers that demand ORs. Therefore, reserve costs are divided between the market agents that have the power system providing reserves. Additionally, electrical consumers can play different roles based on their strategic behaviour in the electricity market to provide or require the ORs. The contributions of this paper are summarized below:

- Proposing a novel method for allocation of the expected reserve costs between GenCos, TransCos, electrical customers and wind farm owners based on the concept that the market player who causes a greater need for the reserve should pay a larger portion of the expected reserve cost.
- Three different approaches are proposed for the apportioning of the expected reserve costs between wind farm owners.
- Consumers are classified based on their strategies of participation in the electricity market, their desired reliability level and the modified flexible function of VOLL.
- Developing a new approach that enables the system operator to apportion the expected reserve cost considering different sources of uncertainty and different types of consumers in terms of providing reserve.

#### *1.4. Paper organization*

The rest of this paper is organized as follows. In Section 2, market formulation is described. The economic metrics that will be utilized to share the reserve costs between market agents are defined in Section 3. A proposed mechanism for reserve cost allocation is described in Section 4. Section 5 states the performance results of the case studies. Section 6 provides the conclusions related to this work.

## **2. Proposed Model**

### *2.1. Model*

In this paper, the SUC problem is solved to achieve optimal requirement OR and apportion reserve costs between EM players. The proposed SUC includes two stages that the first stage presents DAM, and the second stage expresses Real-Time Market (RTM). Besides, energy and reserve- as one type of ancillary services- markets are cleared simultaneously in this problem. Although electrical energy is generated by conventional units and wind farms, OR is provided via conventional units and the group of electrical customers that follow the economic strategy in the EM. In this framework, the DAM is a here-and-now stage (first stage) of the proposed decision-making problem where the uncertainty is not seen in the decisions of this stage [30]. However, the RTM is a wait-and-see stage (second stage) of the SUC problem where uncertainty of wind farms' power output, electrical load and power grid is seen [3], [30]. It is noticeable that operating reserves are defined as decision-making variables and outputs of this problem. Hence, reserves are not forecasted, so their error is not modeled too. In other words, operating reserves are obtained through mathematical formulation and the uncertainty of wind power generation, electrical load, and power grid. Then, the allocated expected reserve costs should be paid by market players when the simultaneous energy and reserve markets are cleared and operating reserves are determined.

## 2.2. Mathematical Formulation

In this section, the objective function of the proposed SUC problem and its constraints are presented.

$$\begin{aligned}
 EC = \sum_{t=1}^{N_T} EC_t = & \sum_{t=1}^{N_T} \sum_{i=1}^{N_G} C_{it}^{SU} \\
 & + \sum_{t=1}^{N_T} d_t \left[ \sum_{i=1}^{N_G} \sum_{m=1}^{N_{Oit}} \lambda_{itm}^G \cdot P_{itm}^G - \sum_{j=1}^{N_L} \lambda_{jt}^L \cdot L_{jt}^S + \sum_{i=1}^{N_G} (C_{it}^{RU} \cdot R_{it}^U + C_{it}^{RD} \cdot R_{it}^D + C_{it}^{RNS} \cdot R_{it}^{NS}) \right. \\
 & \left. + \sum_{j=1}^{N_L} (C_{jt}^{RU} \cdot R_{jt}^U + C_{jt}^{RD} \cdot R_{jt}^D) + \lambda^{WP}_t \cdot P_t^{S,WP} \right] \\
 & + \sum_{\omega=1}^{N_{\Omega}} \pi_{\omega} \cdot \left\{ \sum_{t=1}^{N_T} \sum_{i=1}^{N_G} C_{it\omega}^A \right. \\
 & \left. + \sum_{t=1}^{N_T} d_t \left[ \sum_{i=1}^{N_G} \sum_{m=1}^{N_{Oit}} \lambda_{itm}^G \cdot r_{itm\omega}^G + \sum_{j=1}^{N_L} \lambda_{jt}^L \cdot (r_{jt\omega}^U - r_{jt\omega}^D) + \sum_{j=1}^{N_L} VOLL_{jt} \cdot L_{jt\omega}^{shed} + V_t^S \cdot S_{t\omega} \right] \right\} \quad (1)
 \end{aligned}$$

In (1), the objective function is the total Expected Cost (EC) of the EM. EC consists of the operating costs of the DAM and RTM. Operating costs of the DAM include the start-up cost of units that are shown in the first line. Also, energy cost of units, utility of electrical customers, up/down-ward spinning and nonspinning reserve costs from the generation-side are stated in the second line, respectively. Besides, up/downward spinning reserve costs from the demand-side and the energy cost of wind farms are expressed in the third line. Moreover, the expected costs of the RTM consist of the costs of changing the start-up state of generating units in DAM and RTM that is defined in the fourth line. Additionally, reserve costs related to the generation-side and electrical customer-side, load shedding cost and wind spillage cost can be seen in the fifth line of (1), respectively. As mentioned before, a two-stage SP model is applied to solve the proposed UC problem. First stage (DAM) and second stage (RTM) consist of market balance, power generation bounds, wind power limitation, reserve and start-up cost constraints at scheduling and operation times.

In the following, the EM market constraints consist of the market balance, power generation bounds, wind power limitation, reserve and start-up cost constraints at scheduling and operation time of first stage (DAM) and second stage (RTM) are described:

Subject to:

A. Day-ahead market constraints *Market balance equation*:

$$\sum_{i=1}^{N_G} P_{it}^S + P_t^{S,WP} = \sum_{i=1}^{N_L} L_{jt}^S, \forall t \quad (2a)$$

*Power generation limitations*:

$$P_j \cdot u_{it} \leq P^S_{it} \leq \bar{P}_i \cdot u_{it}, \quad \forall i, \forall t \quad (2b)$$

$$0 \leq p^G_{itm} \leq \bar{p}^G_{itm}, \quad \forall m, \forall i, \forall t \quad (2c)$$

$$P^S_{it} = \sum_{m=1}^{N_{oit}} p^G_{itm}, \quad \forall i, \forall t. \quad (2d)$$

Scheduling wind power generation constraint:

$$P^W_{it} \leq P^S_{it} \leq \bar{P}^W_{it}, \quad \forall t \quad (2e)$$

Operating reserve constraints:

$$0 \leq R_{uit} \leq \bar{R}_{uit} \cdot u_{it}, \quad \forall i, \forall t \quad (2f)$$

$$0 \leq R_{Dit} \leq \bar{R}_{Dit} \cdot u_{it}, \quad \forall i, \forall t \quad (2g)$$

$$0 \leq R_{NSit} \leq \bar{R}_{NSit} \cdot (1 - u_{it}), \quad \forall i, \forall t \quad (2h)$$

$$0 \leq R_{Ujt} \leq \bar{R}_{Ujt}, \quad \forall j, \forall t \quad (2i)$$

$$0 \leq R_{Djt} \leq \bar{R}_{Djt}, \quad \forall j, \forall t \quad (2j)$$

The Start-up cost of conventional generations:

$$C^{SU}_{it} \geq \lambda^{SU}_{it} \cdot (u_{it} - u_{i(t-1)}), \quad \forall i, \forall t > 1 \quad (2k)$$

$$C^{SU}_{i(t=1)} \geq \lambda^{SU}_{i(t=1)} \cdot (u_{i(t=1)} - u_{i(0)}), \quad \forall i, t = 1 \quad (2l)$$

$$C^{SU}_{it} \geq 0, \quad \forall i, \forall t. \quad (2m)$$

B. Real-time market constraints:

Market balance equations in all buses of the power system consider wind power generation (wind farm is located in bus  $r$ -th.):

$$i:(i,n) \quad j:(j,n) \quad \forall n = r, \forall t, \forall \omega. \quad (3b)$$

$$-\sum_{r:(n,r)} f_{t\omega(n,r)} = 0,$$

$$\sum P_{Git\omega} - \sum (LC_{jt\omega} -$$

Power flow equation and limitation:

$$L_{jt\omega} - \sum_{i:(i,n)} f_{t\omega(n,r)} = 0, \forall n \neq r, \forall t, \forall \omega. \quad (3a)$$

$$i:(i,n) \quad j:(j,n) \quad r:(n,r)$$

$$f_{t\omega(n,r)} = \frac{P^{loss}_{t\omega(n,r)}}{2} + B_{(n,r)} \cdot (\delta_{t\omega n} - \delta_{t\omega r}), \quad \forall (n,r) \in \Lambda, \forall t, \forall \omega \quad (3c)$$

$$-\bar{f}_{(n,r)} \leq f_{t\omega(n,r)} \leq \bar{f}_{(n,r)}, \quad \forall (n,r) \in \Lambda, \forall t, \forall \omega.$$

(3d) Linear approximation of power transmission loss is modelled in this paper.

More information on this modelling is provided in [34].

Power generation constraints:

$$P^G_{it\omega} \geq P_j \cdot v_{it\omega}, \quad \forall i, \forall t, \forall \omega. \quad (3e)$$

$$P_{it\omega}^G \leq \bar{P}_i \cdot v_{it\omega}, \quad \forall i, \forall t, \forall \omega. \quad (3f)$$

*Load shedding constraint:*

$$0 \leq L_{jt\omega}^{shed} \leq LC_{jt\omega}, \quad \forall j, \forall t, \forall \omega. \quad (3g)$$

*Wind spillage constraint:*

$$0 \leq S_{t\omega} \leq P_{t\omega}^{WP}, \quad \forall t, \forall \omega. \quad (3h)$$

*Allocated energy and operating reserves:*

$$P_{Git\omega} - P_{Sit} = r_{Uit\omega} + r_{NSit\omega} - r_{Dit\omega}, \quad \forall i, \forall t, \forall \omega. \quad (3i)$$

$$LC_{jt\omega} - LS_{jt} = r_{Djt\omega} - r_{Ujt\omega}, \quad \forall j, \forall t, \forall \omega. \quad (3j)$$

*Operating reserves constraints:*

$$0 \leq r_{it\omega}^U \leq R_{it}^U, \quad \forall i, \forall t, \forall \omega. \quad (3k)$$

$$0 \leq r_{it\omega}^D \leq R_{it}^D, \quad \forall i, \forall t, \forall \omega. \quad (3l)$$

$$0 \leq r_{it\omega}^{NS} \leq R_{it}^{NS}, \quad \forall i, \forall t, \forall \omega. \quad (3m)$$

$$0 \leq r_{jt\omega}^U \leq R_{jt}^U, \quad \forall j, \forall t, \forall \omega. \quad (3n)$$

$$0 \leq r_{jt\omega}^D \leq R_{jt}^D, \quad \forall j, \forall t, \forall \omega. \quad (3o)$$

$$r_{Uit\omega} + r_{NSit\omega} - r_{Dit\omega} = \sum_{m=1}^{NOit} r_{itm\omega}^G, \quad \forall i, \forall t, \forall \omega. \quad (3p)$$

$$r_{itm\omega}^G \leq \bar{p}_{itm} - p_{itm}, \quad \forall i, \forall t, \forall \omega. \quad (3q)$$

$$r_{itm\omega}^G \geq -p_{itm}^G, \quad \forall m, \forall i, \forall t, \forall \omega. \quad (3r)$$

(3i) to (3o) explain the relationship between variables of the day-ahead and real-time markets. (3i) represents that the difference between the power generation of units in the real-time and day-ahead markets should be provided by up/down-ward spinning and non-spinning reserves of each unit. Moreover, the differences of electrical consumption of each customer should be provided by the corresponding demandside up/down-ward reserves as stated in (3j). (3k)-(3o) represent deployed reserve determination constraints related to the up/down-ward spinning and non-spinning reserves of the generation-side and up/down-ward spinning reserves of the demand-side, respectively. (3p) is restatement of (2d) and it stands for the decomposition of the reserve deployment by generation units' blocks through variables  $r_{itm\omega}^G$ . Also, (3q) and (3r) state that the reserve is increased/decreased in case of up/down-spinning reserve to the energy.

*Start-up cost due to the commitment of new generation units in the real-time market:*

$$C_{Ait\omega} = CS_{Uit\omega} - CS_{Uit}, \quad \forall i, \forall t, \forall \omega. \quad (3s)$$

$$CS_{Uit\omega} \geq \lambda_{it}^{SU} \cdot (v_{it\omega} - v_{i(t-1)\omega}), \quad \forall i, \forall t > 1, \forall \omega. \quad (3t)$$

$$C_{i(t=1)\omega}^{SU} \geq \lambda_{i(t=1)}^{SU} \cdot (v_{i(t=1)\omega} - u_{i(0)}), \quad \forall i, t = 1 \quad (3u)$$

$$C_{it\omega}^{SU} \geq 0, \quad \forall i, \forall t, \forall \omega. \quad (3v)$$

### 3. Determination Metrics to apportion Expected Reserve Costs

#### 3.1. Customers-side

Electrical customers play an essential role on needed OR in the power system. Their first effect due to electrical load uncertainty, is that they unbalance electrical generation and consumption, causing the OR to provide customer demand. The second factor is the strategic behavior of electrical customers who can assist or force the system to provide the requirement reserve. In this paper, electrical consumers are divided into three groups. The first group are the customers that participate in the EM as flexible loads. The second group are the customers that do not follow economic aims in the EM, and they desire lower reliability level lower than the power system's standard level. The third set are the customers who desire higher reliability level than the standard level of the system, and they are exactly the ones who force the stochastic power system to provide more OR for them, so they are responsible for paying their portion of the reserve costs. *Demand Factors* (DFs) of electrical consumers, defined for the first time in [3], are used in this paper in order to express the desired reliability level of customers.

$$(4a) \quad \sum_{\omega=1}^{\Omega} \pi_{\omega} \cdot L_{jt\omega} = shedEENS_{jt}$$

$$(4b) \quad DF_j = \sum_{t=1}^{N_T} \frac{EENS_{jt}}{L^S_{jt}}$$

$$DF_j \leq DF_j^{des} \tag{4c}$$

Here, customers are classified into different groups based on their desired DFs as seen in (4c). Then, the flexible VOLL of customers is obtained. It should be mentioned that this modified flexible function of VOLL is defined in this paper for the first time. (4a)-(4c) represent extra load shedding constraints that are modelled in the SUC problem. In this proposed method, the  $DF_j^{des}$  will be equal to  $DF^{std}$ , if customer j desires higher DF than standard DF of the power system as stated in (4d).

If  $DF_{jdes} \geq DF_{std}$  :

$$DF_{jdes} = DF_{std} \tag{4d}$$

Hence, customers are classified into different groups based on their desired DFs as seen in (4e). Moreover, all the electrical consumers that desire DFs higher than  $DF^{std}$  have the same amount of VOLL which is called  $VOLL_{Base}$ . In other words, these customers are placed in one group based the amount of their VOLL. However, their primary desired DFs are different.

$$DF_{NdesM} < \dots < DF_{2des} < DF_{1des} \tag{4e}$$

$$VOLL_{NM} \geq \dots \geq VOLL_2 \geq VOLL_1 \tag{4f}$$

$$VOLL_j = \frac{\sum_{M=1}^{N_M} DF_j^{des}}{DF_j^{des}} \times VOLL_{Base} \tag{4g}$$

From (4f) and (4g), the EC is increased if customers desire a higher reliability level to the standard reliability level of the system. This is because the direct impact that customer choice of reliability has on VOLL, which increases load shedding cost. Also, more reserve is needed to maintain this reliability level so that reserve costs will be increased. This increment of reserve costs should be paid by customers who desire a higher reliability level than the system’s standard level. The portion of reserve costs that should be paid by customers is explained in Section 4.2.

As highlighted, uncertainty of the electrical load is one of the factors that can have a negative influence on reserve costs. In this paper, *Load Uncertainty Cost* (LUC) is defined as an economic metric for attribution of load uncertainty in costs of reserve. Hence, the expected reserve cost is obtained in (4h).

$$RC_t = \sum_{i=1}^{N_G} (C_{Rvit}. R_{Uit} + C_{RDit}. R_{Dit} + C_{RNSit}. R_{NSit}) + \sum_{j=1}^{N_L} (C_{RUjt}. R_{Ujt} + C_{RDjt}. R_{Djt}) \tag{4h}$$

$$LUC_t = RC_{*t0} - RC_{t0} \tag{4i}$$

Where,  $RC_{*t}^0$  is the expected reserve cost considering electrical load uncertainty, while  $RC_t^0$  is the expected costs of reserve considering electrical load as a deterministic variable.

### 3.2. GenCos-side and TransCos-side

The state of the power grid (which includes conventional units and transmission lines) is one of the factors that has a great impact on the amount of the requirement reserve provided. Hence, the uncertainty of the power grid caused by forced outages of generation units and transmission lines has a strong impact on the amount of the required OR. It is clear that more OR is required in power systems with higher Outage Replacement Rate (ORR) than their conventional units and transmission lines. This amount of OR is required to provide the electrical demand and desired reliability level of electrical customers. Hence, a parameter should be utilized to determine the share of GenCos’ uncertainty in the EM.  $EENS^G$  and  $EENS^T$  are stated as metrics to obtain the portions of GenCos and TransCos on the total load shedding of the power system that is due to the shutdown state (0 commitment status) of the GenCos and loss of each transmission lines, respectively.

NL

$$-v_{it\omega} \cdot M \leq EENS_{it\omega}^G - \sum_{j=1}^{N_L} L_{jt\omega}^{shed} \leq v_{it\omega} \cdot M \tag{5a}$$

$$0 \leq EENS_{it\omega}^G \leq \sum_{j=1}^{N_L} \bar{L}_{jt\omega} \cdot (1 - v_{it\omega}) \tag{5b}$$

$$-z_{(n,r)t\omega} \cdot M \leq EENS_{(n,r)t\omega}^T - \sum_{j=1}^{N_L} L_{jt\omega}^{shed} \leq z_{(n,r)t\omega} \cdot M \tag{5c}$$

$$0 \leq EENS_{(n,r)t\omega}^T \leq \sum_{j=1}^{N_L} \bar{L}_{jt\omega} \cdot (1 - z_{(n,r)t\omega}) \tag{5d}$$

In (5a) and (5c),  $M$  represents a large positive parameter that gives enough freedom for variables between inequalities to be feasible. As seen in (5a) and (5b), if  $v_{it\omega}$  is equal to 1,  $EENS_{it\omega}^G$  will be zero. While  $EENS_{it\omega}^G$  equals  $\sum_{j=1}^{N_L} L_{jt\omega}^{shed}$  if  $v_{it\omega}$  is equal to zero. Besides,  $z_{(n,r)t\omega}$  is defined as a binary variable that represents the states of transmission lines in (5c) and (5d). Hence, if  $z_{(n,r)t\omega}$  equals zero,  $EENS_{(n,r)t\omega}^T$  is equal to  $\sum_{j=1}^{N_L} L_{jt\omega}^{shed}$ . Otherwise,  $EENS_{(n,r)t\omega}^T$  equals zero. Besides, the standard reliability level of the power system should be provided. Therefore,  $DF^{sys}$  should maintain  $DF^{std}$  as expressed in (5i).

$$EENS_{it}^G = \sum_{\omega=1}^{\Omega} \pi_{\omega} \cdot EENS_{it\omega}^G \tag{5e}$$

$$EENS_{(n,r)t}^T = \sum_{\omega=1}^{\Omega} \pi_{\omega} \cdot EENS_{(n,r)t\omega}^T \tag{5f}$$

$$DF^{sys} = \sum_{t=1}^{N_T} \left( \frac{EENS_t^{sys}}{\sum_{j=1}^{N_L} L^S} \right) \tag{5g}$$

$$EENS_t = \sum_{i=1}^{N_G} EENS_{it}^G + \sum_{(n,r)} EENS_{(n,r)t}^T \tag{5h}$$

$$DF_{sys} \leq DF_{std} \tag{5i}$$

Furthermore, the congestion of the transmission lines can be another factor raising the need for more OR. Therefore, the cost of reserve is increased where congestion in the lines occurs. In this paper, the *Congestion Factor* (CF) is defined as an economic metric for attributing the reserve cost to TransCos based on the effect of transmission lines congestion on the operation reserve costs.

$$CF_{(n,r)t} = RC_t^{-1} - RC_t^0 \tag{5j}$$

Here,  $RC_t^{-1}$  is the expected reserve cost when congestion has occurred in transmission line (n,r), while  $RC_t^0$  is the expected cost of reserve when not considering congestion constraint in line (n,r).

### 3.3. Wind Farms-side

Uncertainty and variation in energy production are increased in the power system with high penetration of renewable energies especially wind energy. This is because of stochastic behavior and sudden changes in the wind speed which inject the uncertainty of wind farms' power output into the power system, creating the stochastic power system. Hence, the uncertainty of wind power generation is one of the important factors that affect the need of OR in the systems. Here, *Average Benefit of operating* (ABO) and *Hourly Average Benefit of operating* (HABO) are defined as metrics that determine the portion of wind farms' energy and power generation on the expected reserve costs.

$$ABO = \frac{RC_{total*} - RC_{*total0}}{P^{G,WE}} \tag{6a}$$

$$HABO_t = \frac{RC_t^* - RC_t^{*0}}{P_t^{G,W}} \tag{6b}$$

Here,  $RC^*$  represents the expected reserve cost when wind farms are in the power system, and  $RC^{*0}$  is the OR cost without considering wind power generation.  $P^{G,WE}$  and  $P_t^{G,W}$  stand for the expected wind energy generation and wind power generation in period t injected into the power grid, respectively. In our proposed method, the expected wind power and energy generation are indicators for the impact of both wind power generation probability and prediction accuracy on the total reserve costs.  $P^{G,WE}$  and  $P_t^{G,W}$  are obtained by (6c) and (6d).

$$P_t^{G,W} = \sum_{\omega=1}^{\Omega} \pi_{\omega} \cdot (P_{t\omega} - S_{t\omega}) \tag{6c}$$

$$P^{G,WE} = \sum_{t=1}^{N_T} P_t^{G,W} \tag{6d}$$

## 4. A Novel Method to Allocate Expected Reserve Costs

### 4.1. Wind Farm Owners

Uncertainty of wind power generation increases the need of operating reserves. Therefore, reserve costs are increased according to the uncertainty of wind power, and wind farm owners are responsible for paying their portion of reserve costs. In this section, we propose for the first time three different approaches to determine the fraction of wind farm owners that must pay the allocated expected reserve costs. Hence, the portions of the allocated expected reserve costs to be paid by other market's agents do not depend on the

three proposed approaches for allocating reserve costs between wind farm owners. In the first step of all proposed approaches, total expected reserve cost should be obtained from (4h). Other steps make differences in these approaches that will be explained in the following.

*4.1.1 Hierarchical Approach:* In this approach, it is assumed that the chronological order of installing and operating wind farms is known. Hence, the impact of wind farms on system reserve costs is assessed per their chronological order. In this case, the amount of  $RC^{*0}$  will be different for each wind farm. Also,  $RC_k^{*0}$  is the amount of reserve cost when wind farm in the  $k^{th}$  chronological order is added to the power system.

It is clear that the amount of  $RC_1^{*0}$  is equal to  $RC^{*0}$  because the reserve cost of the system without wind power generation of wind farm 1 is equal to the absence of a wind farm in the power system. However, the amount of  $RC_2^{*0}$  is different with  $RC^{*0}$ .  $RC_2^{*0}$  is the amount of system's reserve cost when wind farm 2 does not exist in a power system, and only impacts the wind uncertainty of wind farm 1, considered in the system. Hence,  $RC_2^{*0}$  will equal  $RC_1^*$ . This definition can be extended for the rest of the wind farms.

$$RC_{kt}^{H0} = RC_{(k-1)t}^{H*} , \quad \forall k = 2, \dots, N_W \tag{7a}$$

Therefore, the portions of wind farms that pay the allocated expected reserve costs are obtained:

$$ABO_k^H = \frac{RC_{totalk}^{H*} - RC_{total(k-1)}^{H*}}{P_k^{G,WE}} , \quad \forall k = 2, \dots, N_W, \forall t \tag{7b}$$

$$HABO_{kt}^H = \frac{RC_{kt}^{H*} - RC_{(k-1)t}^{H*}}{P_{kt}^{G,W}} , \quad \forall k = 2, \dots, N_W, \forall t \tag{7c}$$

Net reserve cost is obtained:

$$RC_{net}^H = RC_t^H - \sum_{k=1}^{N_W} HABO_{kt}^H \times P_{kt}^{G,W} \times h_{kt} , \quad \forall k, \forall t \tag{7d}$$

$$RC_{total}^H = RC_{total}^H - \sum_{k=1}^{N_W} ABO_k^H \times P_k^{G,WE} \times H_k , \quad \forall k \tag{7e}$$

$h_{kt}$  and  $H_k$  are binary variables that are equal to 1 if  $HABO_{kt}^H$  and  $ABO_k^H$  are positive, respectively. According to the hierarchical approach, the difference between total expected reserve cost and net reserve cost should be paid by wind farm owners while ABO or HABO are positive. Hence, the owner of wind farm  $N_W$  is not

responsible for paying the costs of reserve if  $ABO_{N_w}^H$  or  $HABO_{N_w t}^H$  are non-positive. Therefore, the portion of the allocated expected reserve cost to be paid by each wind farm is obtained by (7f):

$$RC_{kt}^{W,H} = RC_{kt}^{H*} - RC_{(k-1)t}^H, \quad \forall k = 2, \dots, N_w, \forall t \quad (7f)$$

$$RC_{kt}^{W,H} = RC_{kt}^H - RC_t^{*0}, \quad \forall k = 1, \forall t$$

*4.1.2 Direct Approach:* In this approach, the total expected reserve cost of the system is determined when there is no injection of wind power generation in the system. Then, the direct impact of each wind farm, for instance wind farm  $N_w$ , on reserve cost of the power system is only obtained when the supposed wind farm, wind farm  $N_w$ , is considered in the power system. The amount of reserve cost corresponding to each wind farm is called  $RC_{kt}^{D*}$ . Therefore, portions of wind farms that pay the allocated expected reserve costs are obtained:

$${}^D RC_{total k}^{D*} - RC_{total}^{*0} ABO_k = \frac{RC_{total k}^{D*} - RC_{total}^{*0}}{P_k^{G,WE}}, \quad \forall k, \forall t \quad (8a)$$

$$HABO_{kt}^D = \frac{RC_{kt}^{D*} - RC_t^{*0}}{P_{kt}^{G,W}}, \quad \forall k, \forall t \quad (8b)$$

In this case, net reserve cost will be:

$${}_{net} RC_t = RC_t - \sum_{k=1}^{N_w} HABO_{kt}^D \times P_{kt} \times d_{kt}, \quad \forall k, \forall t \quad (8c)$$

$$RC_{total net} = RC_{total} - \sum_{k=1}^{N_w} ABO_{kD} \times P_{kG,WE} \times D_k, \quad \forall k \quad (8d)$$

$d_{kt}$  and  $D_k$  are binary variables that equal 1 if  $HABO_{kt}^D$  and  $ABO_k^D$  are positive, respectively. As in the hierarchical method, in the direct approach, wind farm owners are responsible for paying the reserve costs when their corresponding ABO and HABO are positive. Hence, the share of each wind farm owner to pay the allocated reserve cost is obtained by (8e):

$$RC_{kt}^{W,D} = RC_{kt}^D - RC_t^{*0}, \quad \forall k, \forall t \quad (8e)$$

*4.1.3 Indirect Approach:* First step of this method is the same as the direct approach. Hence,  $RC_t^{*0}$  is obtained in the first step. Then, the reserve cost of the system is determined when all wind farms are considered in

$${}_{net} RC_t = RC_t - \sum_{k=1}^{N_w} HABO_{kt}^D \times id_t \times P_{kt}, \quad \forall k, \forall t$$

the power system, so the net reserve cost is determined by (9c) and (9d).

$$ABO^{ID} = \frac{RC_{total}^{ID*} - RC_{total}^{*0}}{\sum_{k=1}^{N_W} P_k^{G,WE}}, \quad \forall k, \forall t \quad (9a)$$

$$HABO_t^{ID} = \frac{RC_t^{ID*} - RC_t^{*0}}{\sum_{k=1}^{N_W} P_{kt}^{G,W}}, \quad \forall k, \forall t \quad (9b)$$

(9c)

$$RC_{total} = RC_{total} - ABO \times ID \times \sum_{k=1}^{N_W} P_k, \quad \forall k \quad (9d)$$

$id_t$  and  $ID$  are binary variables that are equal to 1 if  $HABO_t^{ID}$  and  $ABO^{ID}$  are positive. In this case, allocated reserve costs of wind farms are obtained as following:

$$ABO_k^{ID} = ABO^{ID} \times \frac{\alpha_k \times P_k^{G,WE}}{\sum_{k=1}^{N_W} \alpha_k \times P_k^{G,WE}}, \quad \forall k, \forall t \quad (9e)$$

$$HABO_{kt}^{ID} = HABO_t^{ID} \times \frac{\alpha_k \times P_{kt}^{G,W}}{\sum_{k=1}^{N_W} \alpha_k \times P_{kt}^{G,W}}, \quad \forall k, \forall t \quad (9f)$$

$$RC_{kt}^{W,ID} = (RC_t^{ID*} - RC_t^{*0}) \times \frac{\alpha_k \times P_{kt}^{G,W}}{\sum_{k=1}^{N_W} \alpha_k \times P_{kt}^{G,W}}, \quad \forall k, \forall t \quad (9g)$$

$\alpha_k$  is the wind power prediction accuracy of wind farm  $k$ . From (9g), it is clear that if wind power prediction accuracy is equal for all wind farms, then (9g) can be replaced by (9h):

$$RC_{kt}^{W,ID} = (RC_t^{ID*} - RC_t^{*0}) \times \frac{P_{kt}^{G,W}}{\sum_{k=1}^{N_W} P_{kt}^{G,W}}, \quad \forall k, \forall t \quad (9h)$$

(9h) indicates that more reserve costs should be paid by wind farm owners which inject more wind power generation into the power system.

#### 4.2. Electrical Customers

Electrical consumers impact on the increase of reserve costs based on their load uncertainty and their desired reliability level. In this section, LUC is utilized as an economic metric to apportion the reserve costs through electrical customers based on their demand uncertainty as stated in (10a). The portion of customers to pay the expected cost of reserves is determined by (10b).

$$LUC_t = RC_t^{net} - RC_t^0 \tag{10a}$$

$$RC_{jt}^{LUC} = LUC_t \times \frac{\beta_j \times L_{jt}^S}{\sum_{j=1}^{NL} \beta_j \times L_{jt}^S} \tag{10b}$$

Where,  $\beta_j$  is the electrical load prediction accuracy of customer  $j$ . If it is supposed that the prediction accuracy of all electrical loads is equal, then (10b) is replaced by (10c).

$$RC_{jt}^{LUC} = LUC_t \times \frac{L_{jt}^S}{\sum_{j=1}^{NL} L_{jt}^S} \tag{10c}$$

Furthermore, the portion of electrical customers to pay the expected cost of reserve that is allocated based on the customer choice of reliability is achieved by (10d).

$$RC_{jt}^{CC} = \frac{VOLL_j}{\sum_{j=1}^{NL} VOLL_j} \times RC_t^0 \tag{10d}$$

#### 4.3. GenCos and TransCos

The uncertainty of the power grid is one of the reasons why more ORs are required. Therefore, GenCos and TransCos should be responsible for paying the allocated expected reserve costs based on the ORR and failures of generation units and transmission lines. The portion of GenCos and TransCos to be paid the reserve costs is obtained by (11a) and (11b), respectively.

$$RC_{ijt}^G = \frac{EENS_{it}^G}{EENS^{sys}} \times RC_{jt}^{CC} \tag{11a}$$

$$RC_{(n,r)jt}^T = \frac{EENS_{(n,r)t}^T}{EENS^{sys}} \times RC_{jt}^{CC} \tag{11b}$$

(11a) and (11b) represent that GenCos and TransCos pay their portion of the reserve costs allocated through customers. This means that  $RC_t^0$  is allocated between electrical customers in the first step. Then, customers who desire higher level of reliability than system standard reliability are responsible for paying the attribution of the reserve costs. However, the attribution reserve costs of customers whose desired reliability levels are lower than the standard level of the power system are allocated between GenCos and TransCos.

Furthermore, TransCos are responsible for paying the expected reserve costs due to the congestion of the lines. Hence, the allocated reserve cost between TransCos based on the transmission lines congestion,  $RC_{(n,r)t}^{T,CF}$ , will be determined by (11c), where  $f_{(n,r)t}^C$  is introduced as a binary variable that equals 1 when congestion occurs only in line  $(n,r)$ .

$$RC_{(n,r)t}^{T,D} = CF_{(n,r)t} \cdot f_{(n,r)t}^C \quad (11c)$$

Additionally, if congestion occurs in more than one transmission line, the direct reserve costs allocated to each TransCo are based on their congestion and total reserve cost when these congestions happen simultaneously- are determined from (11c). Then, the allocated expected reserve costs are obtained through TransCos (11d).

$$RC_{(n,r)t}^{T,ID} = \frac{RC_{(n,r)t}^{T,D}}{\sum_{r:(n,r)} RC_{(n,r)t}^{T,D}} \times \sum_{r:(n,r)} CF_{(n,r)t} \quad (11d)$$

#### 4.4. Framework of Reserve Cost Allocating Algorithm

The proposed algorithm for apportioning of the expected reserve costs between market agents in the power system is described in this section. Also, Fig. 1 describes the proposed method of reserve cost allocation.

Below we summarize, the different steps involved in the proposed method for apportioning of the expected reserve costs:

- Step 1: Electrical customers declare their desired reliability levels and their flexible VOLL is obtained from (4a) -(4g).
- Step 2: ISO dispatch conventional units in a way that provides at least the standard reliability level of the stochastic power system per (5a)- (5i).
- Step 3: Reserve cost is given based on (4h).
- Step 4: The reserve cost is allocated to the TransCos due to congestion in the transmission lines according to (11c) and (11d).
- Step 5: The share of OR costs is allocated to wind farm owners based on one of the proposed approaches that are introduced in this paper for the first time in (6a) –(9h).
- Step 6: The portion of electrical consumers to pay the OR costs based on (10a) –(10d).
- Step 7: The share of GenCos and TransCos to pay the allocated reserve costs according to (11a) and (11b), respectively.

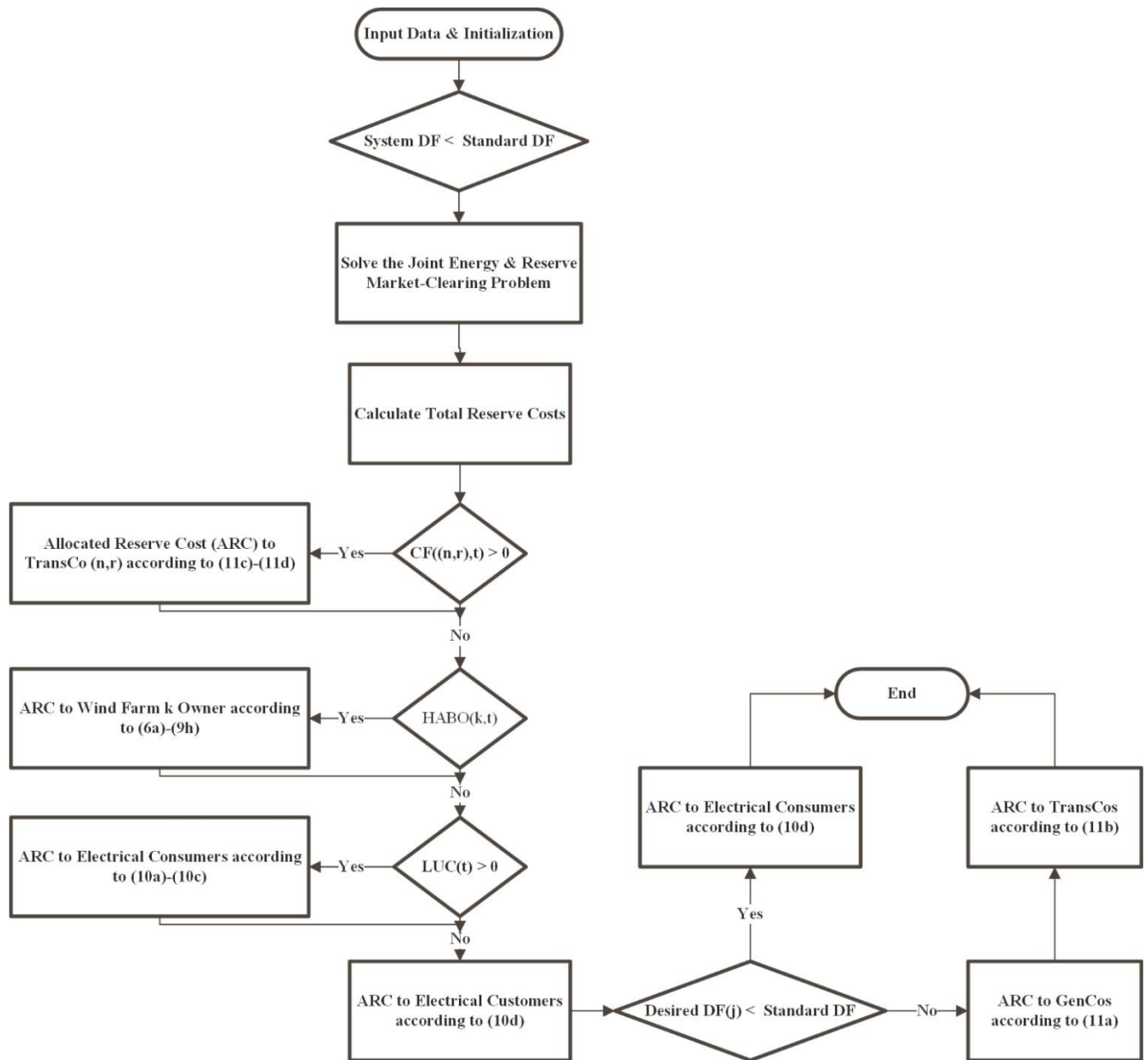

**Figure 1** The proposed algorithm to allocate expected reserve costs between market agents in the power system.

## 5. Simulation Results

### 5.1. 3-Bus Test System

The proposed algorithm for reserve cost allocation is assessed in the modified 3-bus test system that is shown in Fig. 2 of this section. It is considered that there are electrical loads in each bus of the system. The data of the generators and the system are given in [30-31]. Lines capacity is presented in Table 1. Moreover, the wind power generation and load scenarios and their corresponding probabilities are stated in Tables 2 and 3, respectively. Power grid scenarios obtained from ORR equals 0.02 for units and is equal to

0.01 for transmission lines. Besides, the marginal cost of energy offered by the wind farm is supposed to equal five. In addition, standard DF is proposed to be 0.0015. In the following, the class of electrical consumers, the desired DF, the accepted desired DF and the corresponding VOLL of consumers are displayed in Table 4.

**Table 1** Scenarios of load at bus 3 and wind power in 3-buses test system.

| Transmission lines | Capacity (MW) |
|--------------------|---------------|
| Line (1,2)         |               |
| Line (1,3)         |               |
| Line (2,3)         |               |

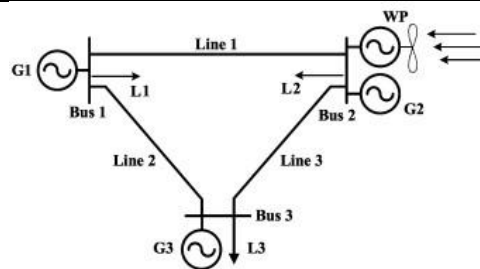

**Figure 2** Modified 3-bus test system [3], [37].

**Table 2** Scenarios of load at bus 3 and wind power in 3-buses test system [9].

| $P_{WP}(t, \omega_w)$ (MW) | Customer 1(MW) | Customer 2 (MW) | Customer 3 (MW) |
|----------------------------|----------------|-----------------|-----------------|
|----------------------------|----------------|-----------------|-----------------|

**Table 3** Scenarios probabilities of load at Bus 3 and Wind Power in 3-buses test system [9].

| Probability | As forecast   |      |     | High          |      |     | Low           |      |     | As forecasted |      |     | High          |      |     | Low |  |  | Table 4<br>Desired |
|-------------|---------------|------|-----|---------------|------|-----|---------------|------|-----|---------------|------|-----|---------------|------|-----|-----|--|--|--------------------|
|             | 0.6           | 0.2  | 0.2 | 0.8           | 0.1  | 0.1 | 0.8           | 0.1  | 0.1 | 0.8           | 0.1  | 0.1 | 0.8           | 0.1  | 0.1 |     |  |  |                    |
| Period t    | As forecasted | High | Low | As forecasted | High | Low | As forecasted | High | Low | As forecasted | High | Low | As forecasted | High | Low |     |  |  |                    |

| DF, determined VOLL, classes of customers and the bus that each customer is located in system tests in 3-bus test system. | $P_{WP}(t, \omega_w)$ (MW) |            |                    | $L^S(t, \omega_l)$ (MW) |         |  |
|---|----------------------------|------------|--------------------|-------------------------|---------|--|
|   | VOLL                       | Desired DF | Class of customers | Strategy                | Bus no. |  |
| Customer 3  | 0.003                      | 0.0015     |                    | Economic Follower       |         |  |
| Customer 2  | 0.002                      | 0.0015     |                    | No Strategy             |         |  |

|            |       |       |                                    |
|------------|-------|-------|------------------------------------|
| Customer 1 | 0.001 | 0.001 | Desired Reliability level Follower |
|------------|-------|-------|------------------------------------|

As seen in Table 4, only customer 1 declares its desired DF lower than standard DF in the power system. Hence, customer 1 is responsible for paying its allocated reserve cost. Besides, the accepted desired DF of customers 2 and 3 is equal to 0.0015 that is the amount of standard DF of the system because they present their desired reliability levels lower than standard reliability level of the system. In other words, customer 1 belongs to the group of electrical consumers which are concerned about the provision of their electrical demand. However, providing their electrical demand with high reliability level is not the priority of customers 2 and 3. In addition, although customer 2 does not follow any strategy in the power system, customer 3 plays as the flexible load pursuing its economic profits to participate in the electricity market. Therefore, customer 3 can help the SO to provide the requirement OR. However, customer 1 forces the power system to maintain more OR to satisfy its desired reliability level. The proposed apportioning reserve cost mechanism between market agents is described step by step, as follows:

5.1.1 *TransCos-side (Congestion)*: Congestion in the transmission lines is the first factor that can have an influence on the system reserve costs. In this case study, the congestion occurs in all transmission lines based on the supposed lines capacity as seen in Table 1. Hence, the allocated reserve costs through TransCos are achieved according to (11d). Table 5 demonstrates the total allocated reserve costs between TransCos due to the congestion of the transmission lines. As shown in Table 5, congestion occurs only in lines (1,2) and (1,3), so their corresponding TransCos are responsible for paying the allocated reserve costs.

**Table 5** Allocated reserve costs (ARCs) between TransCos due to congestion in the transmission lines.

| Time  | Reserve Costs |          | TransCo (1,2) |              | TransCo (1,3) |              | TransCo (2,3) |              |
|-------|---------------|----------|---------------|--------------|---------------|--------------|---------------|--------------|
|       | $RC_t^{-1}$   | $RC_t^0$ | Direct ARC    | Indirect ARC | Direct ARC    | Indirect ARC | Direct ARC    | Indirect ARC |
| 1     | 172.650       | 172.650  | 0             | 0            | 0             | 0            | 0             | 0            |
| 2     | 193.633       | 193.169  | 29.273        | 0.457        | 0.464         | 0.007        | 0             | 0            |
| 3     | 305           | 281      | 0             | 0            | 6.5           | 24           | 0             | 0            |
| 4     | 197.7         | 197.7    | 0             | 0            | 0             | 0            | 0             | 0            |
| Total | 868.983       | 844.519  | 29.273        | 0.457        | 6.964         | 24.007       | 0             | 0            |

5.1.2 *Wind Farm-side*: Wind power generation uncertainty has a negative effect on the amount of requirement OR. After allocating the reserve costs due to the congestion of the transmission lines, and the reserve costs for the wind power uncertainty are obtained in this section. Here, the wind farm owner is responsible for paying the portion of the reserve costs according to step 5 of the reserve cost allocating algorithm. Because there is only one wind farm in this case, there is no difference between the proposed approaches to apportion

reserve costs to the wind farm owner. Table 6 states the share of the wind farm owner to pay the allocated expected reserve costs.

**Table 6** The portion of the allocated reserve costs to be paid by the wind farm owner.

| Time  | $RC_t^*$ | $RC_t^*$ | $P_t^{G,W}$ | $HABO_t$ | Allocated reserve costs related to wind farm owner |
|-------|----------|----------|-------------|----------|--|
|       | 172.650  | 146.032  |             | 2.505    | 26.618   |
|       | 193.633  |          |             | -3.433   |  |
|       |          |          |             | -0.836   |  |
|       | 197.7    | 188.1    |             | -4.069   | 9.6  |
| Total | 868.983  | 784.132  |             | -5.833   | 86.218   |

As seen in Table 6, wind power generation uncertainty only causes to decrease the reserve cost in time period 2. Hence, the wind farm owner should not pay the allocated reserve cost only in time period 2. Moreover, Fig. 3 shows the effect of wind power forecasting accuracy on the reserve cost that is allocated to the wind farm owner. As seen in Fig. 3, improving the prediction accuracy causes a decrease in the amount of reserve costs paid by the wind farm owner.

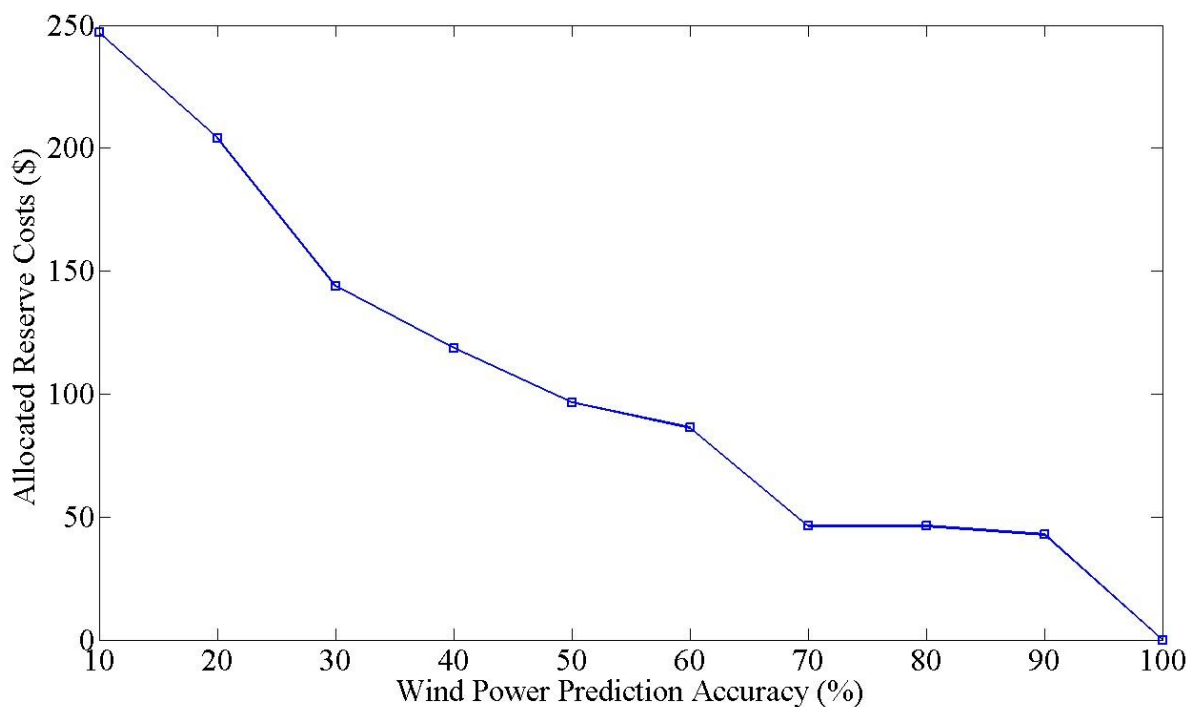

**Figure 3** Impact of wind power prediction accuracy on the expected reserve costs allocated to the wind farm owner.

**5.1.3 Customer-side:** Customers can influence the amount of requirement OR because of their electrical load uncertainty and their desired reliability levels. All customers are responsible for paying their share of allocated expected reserve costs, if load uncertainty causes an increase in the reserve costs. Besides, electrical consumers can participate in the EM based on their desired strategies. As stated before, customer

3 is an economic follower and participate as the flexible load in the EM. Hence, customer 3 assists the power system to provide the ORs. On the other hand, customer 1 requests its desired reliability level, so the power system should provide more OR to satisfy its demand. Table 7 indicates which customer should pay the allocated reserve costs and which should receive the costs of reserve, based on the proposed algorithm. As Shown in Table 7, only customer 1 is responsible for paying the allocated reserve cost because it desires the higher reliability level than the standard level of the stochastic power system. On the other hand, only customer 3 receives the costs of the OR because it provides a portion of the requirement reserves as flexible load.

**Table 7** Received and allocated expected reserve costs to electrical customers.

| Period<br>t | Allocated Reserve Costs based on Received |            |            |                           |            |            |                  |            |            |
|-------------|---|------------|------------|---------------------------|------------|------------|------------------|------------|------------|
|             | Reserve Costs                             |            |            | Desired Reliability Level |            |            | Load Uncertainty |            |            |
|             | Customer 1                                | Customer 2 | Customer 3 | Customer 1                | Customer 2 | Customer 3 | Customer 1       | Customer 2 | Customer 3 |
|             |   |            |            | 96.421                    |            |            | 0.7              | 0.42       | 0.28       |
|             |   |            |            | 119.533                   |            |            | 6.935            | 4.161      | 2.774      |
|             |   |            |            | 142.333                   |            |            | 8.75             | 5.25       | 3.5        |
|             |   |            |            | 117.933                   |            |            | 5.6              | 3.36       | 2.24       |

5.1.4 GenCos-side and TransCos-side: Power grid uncertainty due to the outage rate of generation units and transmission lines is one of the reasons why OR is required in the power system. In our approach, GenCos are responsible for paying the portion of reserve costs allocated to electrical consumers who request their desired reliability to be lower than the system standard reliability. Moreover, as conventional units are the main resources to provide the operating reserves, GenCos receive the share of reserve costs according to the generation-side deployment of reserves. Table 8 states the amount of reserve costs that should be received by GenCos and paid by GenCos and TransCos.

**Table 8** Received and allocated reserve costs to GenCos and TransCos.

| Period | Received Reserve Costs |         | Allocated Reserve Costs based on Desired Reliability Level t |         |               |                          |                          |
|--------|------------------------|---------|--|---------|---------------|--------------------------|--------------------------|
|        | GenCo 3                | GenCo 1 | GenCo 2  | GenCo 3 | TransCo (1,2) | GenCo 2<br>TransCo (1,3) | GenCo 2<br>TransCo (2,3) |
|        | 83.25                  |         |  | 48.211  |               |                          |                          |
|        | 179.763                |         |  | 59.766  |               |                          |                          |
|        | 232.5                  |         |  |         |               | 71.167                   |                          |
|        | 142.5                  |         |  | 58.967  |               |                          |                          |

As seen in Table 8, only Genco 2 and TransCo (1,3) are responsible for paying the share of allocated expected reserve costs because only the outage of unit 2 and transmission line between buses 1 and 3 cause to shed the electrical loads and making it necessary that ORs to maintain the standard reliability level of the power system and the customers' desired reliability levels.

### 5.2. IEEE-RTS

In this section, the IEEE-RTS is used to assess the proposed mechanisms to allocate expected reserve costs between wind farm owners [32]. A single-line diagram of the IEEE-RTS is shown in Fig. 4. The system data, the blocks of energy offered by each GenCos and their corresponding costs are given in [31]. The wind power generation scenarios are stated in Table 9 and the probability of each scenario is based on Table 3 [35]. Also, it is proposed that the wind spillage cost equals 2 \$/MWh, and the offered price of wind farm is assumed to be 1 \$/MWh. It is supposed that there are three wind farms in this system test which are located in buses 1, 13 and 18. Also, total power output generation of these wind farms is stated as a fraction of the wind power generation as shown in Table 9.

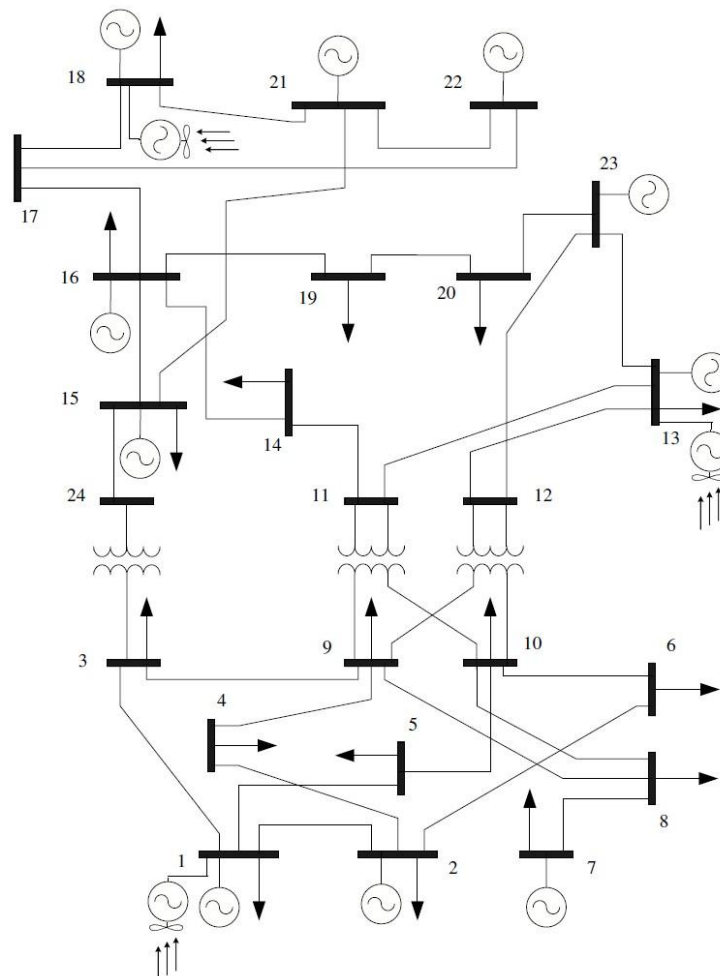

**Figure 4** Single-line diagram of the Modified IEEE-RTS [31], [33].

**Table 9** Scenarios of wind power generation in scenarios 2, 3 and 4 in IEEE-RTS [16].

| Period #      | 1  | 2  | 3  | 4  | 5  | 6  | 7  | 8  | 9  | 10 | 11 | 12 | $P_{to}^{WP}$ (MW) |  |
|---------------|----|----|----|----|----|----|----|----|----|----|----|----|--------------------|--|
| Low           | 24 | 27 | 29 | 35 | 43 | 46 | 42 | 44 | 45 | 49 | 55 | 59 |                    |  |
| As Forecasted | 26 | 29 | 33 | 40 | 45 | 48 | 44 | 46 | 50 | 55 | 60 | 65 |                    |  |
| High          | 28 | 40 | 38 | 42 | 48 | 50 | 48 | 49 | 53 | 61 | 65 | 68 |                    |  |
| Period #      | 13 | 14 | 15 | 16 | 17 | 18 | 19 | 20 | 21 | 22 | 23 | 24 | $P_{to}^{WP}$ (MW) |  |
| Low           | 54 | 60 | 59 | 60 | 61 | 63 | 65 | 67 | 63 | 60 | 50 | 43 |                    |  |
| As forecasted |    |    |    |    |    |    |    |    |    |    |    |    |                    |  |
| High          |    |    |    |    |    |    |    |    |    |    |    |    |                    |  |

Moreover, to clarify the proposed mechanism for allocating expected reserve costs through wind farms, we consider that electrical consumers participate in the EM without any strategy. In the following, two scenarios are defined to evaluate the proposed algorithms based on the penetration factor of each wind farm.

- Scenario 1: Penetration factors of wind farms 1, 13 and 18 are equal to 2, 1 and 1.5, respectively.
- Scenario 2: Penetration factors of wind farms 1, 13 and 18 are equal to 0.6, 0.8 and 0.4, respectively.

*5.2.1 Direct Approach:* As stated in section 4.1.2, the effect of each wind farm on the reserve costs is assessed while only that wind farm is located in the power system. If it causes an increase in the amount of reserve costs, a portion of the reserve cost is allocated to that wind farm. As shown in Table 10, in scenario 1, the direct effect of wind farms’ power generation is an increase in the reserve costs; hence, they are responsible to pay their allocated reserve costs. However, in scenario 2, the power generation of wind farms does not have a direct negative influence on the reserve costs. Therefore, they are not responsible for paying the reserve costs in this case.

**Table 10** Allocated expected reserve costs between wind farm owners.

| Scenarios  | Wind Farms  | Average Benefit of Operating (ABO) (\$/MWh) |          |              | Allocated Reserve Costs (\$) |          |              |
|------------|-------------|---|----------|--------------|------------------------------|----------|--------------|
|            |             | Direct                                      | Indirect | Hierarchical | Direct                       | Indirect | Hierarchical |
|            |             | Approach                                    | Approach | Approach     | Approach                     | Approach | Approach     |
| Scenario 1 | Wind Farm 1 | 0.184                                       | -0.782   | 0.184        | 480.482                      |          | 480.482      |
|            | Wind Farm 2 |   |          |              |                              |          |              |
|            | Wind Farm 3 | 0.745                                       | -0.391   | -3.609       | 972.491                      |          |              |
|            |             | 0.935                                       | -0.586   | -3.117       | 1831.171                     |          |              |
| Scenario 2 | Wind Farm 1 | -3.133                                      | 0.065    | -3.133       |                              | 153.303  |              |
|            | Wind Farm 2 |   |          |              |                              |          |              |
|            | Wind Farm 3 | -2.901                                      | 0.087    | 2.553        |                              | 204.404  | 2667.498     |

|        |       |       |         |         |
|--------|-------|-------|---------|---------|
| -5.153 | 0.044 | 0.471 | 102.202 | 246.022 |
|--------|-------|-------|---------|---------|

*5.2.2 Indirect Approach:* In this mechanism, the expected reserve costs are achieved when all wind farms are considered in the power system. Then, the portion of the reserve cost to be paid by each wind farm is obtained based on their corresponding wind power generation and their wind power prediction accuracy. As the prediction accuracy is assumed to be equal for simplicity in this case, the share of wind farms to pay the reserve costs is determined by (9h). From Table 10, we notice that the integration of wind farms decreases total reserve costs in scenario 1. Therefore, although the direct impact of each wind farm causes the reserve costs to increase, the integration of wind power reduces the reserve costs. In other words, wind farm owners in scenario 1 are not responsible for paying the allocated expected reserve costs according to the indirect approach. On the other hand, in scenario 2, the integration of the wind farms increases the reserve costs, so wind farm owners should pay their corresponding allocated reserve costs based on (9h).

*5.2.3 Hierarchical Approach:* In this case, wind farm 1 is considered as the first one that is installed in the power system. The second one is wind farm 2 and the third one is wind farm 3. Hence, the total reserve costs are obtained when only wind farm 1 is in the power system. In the next step, both wind farms 1 and 2 are considered inject power into the system. Finally, all wind farms are located in the power system. According to the hierarchical approach that is explained in section 4.1.1, there is no difference between the allocated reserve cost to of wind farm 1 based on direct and hierarchical approaches. However, considering wind farms 1 and 2 causes the reserve costs to decrease, so wind farm 2 should not pay the allocated reserve cost in this case. Moreover, the owner of wind farm 3 is not responsible for paying the share of reserve costs because the integration of wind farms in scenario 1 decreases the total operating costs. In scenario 2, although wind farm 1 does not have a negative effect on the reserve costs, considering wind farms 1 and 2 simultaneously raises the amount of reserve costs, so the owner of wind farm 2 should pay this increase in reserve costs that is equal to 2667.498 \$. Furthermore, the integration of wind farms increases the total reserve costs. Hence, the owner of wind farm 3 is responsible for paying its portion of the allocated reserve costs that equals 246.022 \$.

As stated in Table 10, the portion of wind farms that has to pay the allocated expected reserve costs is completely different depending on the applied mechanism to apportion the reserve costs. While all wind farms are responsible for paying the allocated expected reserve costs according to the direct approach in scenario 1, they should pay their portion of reserve costs when the indirect mechanism is applied to scenario 2. This difference is caused by the penetration factors of wind farms power generation. Moreover, the important question is which of these mechanisms would be more practical in the electricity markets.

Although the direct approach is the easiest one for allocating the expected reserve costs between wind farms, this approach does not consider the impact of integrating wind power in the power system. Hence, the indirect and hierarchical approaches are suggested to be applied as the reserve cost allocation mechanisms. However, applying these proposed approaches can have a negative impact on the electricity markets that want to motivate wind farm owners to participate in the markets. Hence, our reserve cost allocation method is practical in the power system with high penetration of wind power generation.

## 6. Conclusions and Discussions

In this paper, a new algorithm is proposed to allocate the reserve costs through market agents based on their stochastic behavior contribution to the social welfare in the power system. One of the advantages of the proposed mechanism to allocate the expected reserve costs is that the electrical customers are free to participate in the electricity market based on their desired strategies which consist of economic and reliability strategies. Hence, the flexible VOLL for each customer is defined based on their strategic behaviour. Another advantage of the proposed mechanism is to pursue covering the expected reserve costs through electricity market players as fairly as possible. In other words, in our proposed mechanism to apportion the expected reserve costs, each electricity market participant who makes the need of reserve is responsible for its corresponding reserve cost. However, the current electricity markets fixed allocation rate policies for reserve costs are not fair enough. Hence, in the proposed mechanism, the reserve costs are allocated between GenCos, TransCos and customers. GenCos and TransCo are responsible for paying a share of the allocated reserve costs if the failures of conventional units and transmission lines make it necessary to see operating reserves, respectively. Besides, TransCos should pay a portion of reserve costs if their congestion causes the reserve costs to increase according to the *congestion factor* which has been defined as an economic metric in this paper. However, there are also some disadvantages of the proposed method. For instance, apportioning the reserve costs to GenCos can impact negatively on the electrical customers. This way, GenCos may increase their corresponding energy price to compensate their loss of reserve cost.

Additionally, only the customers who declare their desired reliability levels higher than standard level of the system are responsible for paying a share of reserve costs. However, all electrical consumers should pay their portion of the allocated expected reserve costs based on the electrical load uncertainty according to the *load uncertainty cost* that is also defined as a new economic metric in this paper. Moreover, wind farm owners are responsible for paying a portion of reserve costs based on the economic metrics (that are called *average benefit of operating* and *hourly average benefit of operating*), and three proposed mechanisms (consisting direct, indirect and hierarchical approaches) that are introduced in this paper for the first time. Finally, according to the simulation results in this paper, indirect and hierarchical approaches perform better

in the allocation of expected reserve costs among wind farm owners. However, it should be highlighted that allocating the reserve costs between wind farm owners can demotivate them to participate in these markets. Therefore, the proposed reserve cost allocation mechanism is practical in the power systems with high penetration of wind power generation.

## 7. References

1. A. Daraeepour, S. J. Kazempour, D. Patiño-Echeverri, and A. J. Conejo, "Strategic demand-side response to wind power integration", *IEEE Trans. Power Syst.*, vol. 31, no. 5, pp. 3495-3505, Sep. 2016.
2. S. J. Kazempour, A. J. Conejo, and C. Ruiz, "Strategic bidding for a large consumer", *IEEE Trans. Power Syst.*, vol. 30, no. 2, pp. 848-856, Mar. 2015.
3. A. Shokri Gazafroudi, K. Afshar, N. Bigdeli, "Assessing the operating reserves and costs with considering customer choice and wind power uncertainty in pool-based power market", *Inter. J. of Elec. Power & Energy Syst.*, vol. 67, pp. 202-215, May 2015.
4. Y. Dvorkin, H. Pandžić, M. A. Ortega-Vazquez, and D. S. Kirschen, "A hybrid stochastic/interval approach to transmission-constrained unit commitment", *IEEE Trans. Power Syst.*, vol. 30, no. 2, pp. 621-631, Mar. 2015.
5. H. Pandžić, Y. Dvorkin, T. Qiu, Y. Wang, and D. S. Kirschen, "Toward cost-efficient and reliable unit commitment under uncertainty", *IEEE Trans. Power Syst.*, vol. 31, no. 2, pp. 1-13, June 2015.
6. R. Fernandez-Blanco, Y. Dvorkin, and M. A. Ortega-Vazquez, "Probabilistic security-constrained unit commitment with generation and transmission contingencies", *IEEE Trans. Power Syst.*, vol. PP, no. 99, Apr. 2016.
7. Y. Dvorkin, M. A. Ortega-Vazquez, D. S. Kirschen, "Wind generation as a reserve provider", *IET Gen., Transm., Distrib.*, vol. 9, no. 8, pp. 779-787, May 2015.
8. J. D. Lyon, Kory W. Hedman, and M. Zhang, "Reserve requirements to efficiently manage intra-zonal congestion", *IEEE Trans. Power Syst.*, vol. 29, no. 1, pp. 251-258, Jan. 2014.
9. P. Yu, B. Venkatesh, "Fast security and risk constrained probabilistic unit commitment method using triangular approximate distribution model of wind generators", *IET Gen., Transm., Distrib.*, vol. 8, no. 11, pp. 1778-1788, Nov. 2014.
10. S. Lou, S. Lu, Y. Wu, and Daniel S. Kirschen, "Optimizing spinning reserve requirement of power system with carbon capture plants", *IEEE Trans. Power Syst.*, vol. 30, no. 2, pp. 1056-1063, Mar. 2014.
11. J. Rameshkumar, S. Ganesan, M. Abirami, S. Subramanian, "Cost, emission and reserve pondered predispatch of thermal power generating units coordinated with real coded grey wolf optimisation", *IET Gen., Transm., Distrib.*, vol. 10, no. 4, pp. 972-985, Mar. 2016.
12. H. Pandzic, Y. Dvorkin, Y. Wang, T. Qiu, and D. S. Kirschen, "Effect of time resolution on unit commitment decisions in systems with high wind penetration", *Proc. PES Gen. Meet.*, 27-31, July 2014.
13. Zh. Wang, Q. Bian, H. Xin, and D. Gan, "A distributionally robust co-ordinated reserve scheduling model considering CVaR-based wind power reserve requirements", *IEEE Trans. on Sustain. Energy*, vol. 7, no. 2, pp. 625-639, Apr. 2016.

14. P. N. Beuchat, J. Warrington, T. H. Summers, and M. Morari, “performance bounds for look-ahead power system dispatch using generalized multistage policies”, *IEEE Trans. Power Syst.*, vol. 31, no. 1, pp. 474-484, Jan. 2016.
15. F. Wang, and Kory W. Hedman, “Dynamic reserve zones for day-ahead unit commitment with renewable resources”, *IEEE Trans. Power Syst.*, vol. 30, no. 2, pp. 612-620, Mar. 2015.
16. J. Saez-Gallego, J. M. Morales, H. Madsen, T. Jonsson, “Determining reserve requirements in DK1 area of Nord pool using a probabilistic approach”, *Energy*, vol. 74, pp. 682-693, Sep. 2014.
17. K. D. Vos, J. Driesen, “Dynamic operating reserve strategies for wind power integration”, *IET Renew. Power Gen.*, vol. 8, no. 6, pp. 598–610, Aug. 2014.
18. W. Wei, J. Wang, and Sh. Mei, “Dispatchability maximization for co-optimized energy and reserve dispatch with explicit reliability guarantee”, *IEEE Trans. Power Syst.*, vol. 31, no. 4, pp. 3276-3288, July 2016.
19. J. M. Morales, M. Zugno, S. Pineda, Pierre Pinson, “Electricity market clearing with improved scheduling of stochastic production”, *Europ. J. Operat. Research*, vol. 235, no. 2, pp. 765-774, June 2014.
20. J. M. Morales, M. Zugno, S. Pineda, and P. Pinson, “Redefining the merit order of stochastic generation in forward markets”, *IEEE Trans. Power Syst.*, vol. 29, no. 2, pp. 992-993, Mar. 2014.
21. A. Nasri, S. J. Kazempour, A. Conejo, M. Ghandhari, “Network-constrained AC unit commitment under uncertainty : a Benders’ decomposition approach”, *IEEE Trans. Power Syst.*, vol. 31, no. 1, pp. 412-422, Jan. 2016.
22. H. Falsafi, A. Zakariazadeh, S. Jadid, “The role of demand response in single and multi-objective windthermal generation scheduling: a stochastic programming”, *Energy*, vol. 64, pp. 853-867, Jan. 2014.
23. F. A. Campos, A. M. S. Roque, E. F. Sánchez-Úbeda, and J. P. González, “Strategic Bidding in Secondary Reserve Markets”, *IEEE Trans. Power Syst.*, vol. 31, no. 4, pp. 2847-2856, July 2016.
24. M. Najafi, M. Ehsan, M. Fotuhi-Firuzabad, A. Akhavein, K. Afshar. “Optimal reserve capacity allocation with consideration of customer reliability requirements”, *Energy*, vol. 35, no. 9, pp. 3883- 3890, Sep. 2010.
25. P. Wang, L. Goel, “Reliability- based reserve management in a bilateral power market”, *Elect. Power Syst. Res.*, vol. 67, no. 3, pp. 185- 189, Dec. 2003.
26. A. Ahmadi-Khatir, M. Fotuhi-Firuzabad, L. Goel, “Customer choice of reliability in spinning reserve procurement and cost allocation using well-being analysis”, *Elect. Power Syst. Res.*, vol. 79, no. 10, pp. 1431-1440, Oct. 2009.
27. A. Ahmadi-Khatir, R. Cherkaoui, “A probabilistic spinning reserve market model considering Disco’ different value of lost load”, *Elect. Power Syst. Res.*, vol. 81, no. 4, pp. 862- 872, Apr. 2011.
28. T. W. Haring, D. S. Kirschen, G. Andersson, “Efficient allocation of balancing and ramping costs”, *Proc. Power Syst. Comput. Conf. (PSCC)*, 18-22, Aug. 2014.
29. A. I. Negash, T. W. Haring, and D. S. Kirschen, “Allocating the cost of demand response compensation in whole sale energy markets”, *IEEE Trans. Power Syst.*, vol. 30, no. 3, May 2015.
30. J. Morales, A. Conejo, J. Perez- Ruiz, “Economic valuation of reserves in power systems with high penetration of wind power”, *IEEE Trans. Power Syst.*, vol. 24, no. 2, pp. 900-910, May 2009.

31. A. J. Conejo, M. Carrion, J. M. Morales, “Decision making under uncertainty in electricity markets”, *Inter. Series in Oper. Res. & Manage. Science*, Springer, 2010.
32. Reliability Test System Task Force, “The IEEE reliability test system 1996. A report prepared by the reliability test system task force of the application of probability methods subcommittee”, *IEEE Trans. Power Syst.*, vol. 14, no. 3, pp. 1010-1020, Aug. 1999.
33. M. Yousefi Ramandi, K. Afshar, A. Shokri Gazafroudi, N. Bigdeli, “Reliability and Economic Valuation of Demand Side Management Programming in Wind Integrated Power Systems”, *Inter. J. of Elec. Power & Energy Syst.*, vol. 78, pp. 258-268, Jan. 2016.
34. A. L. Motto, F. D. Galiana, A. J. Conejo, and J. M. Arroyo, “Network constrained multiperiod auction for a pool-based electricity market”, *IEEE Trans. Power Syst.*, vol. 17, no. 3, pp. 646–653, Aug. 2002.
35. G. Strbac, D.S. Kirschen, “Who should pay for reserve?”, *Electr. J.*, vol. 13, no. 8, pp. 32-37, Oct. 2000.
36. B. Kirby, E. Hirst, “Allocating the costs of contingency reserves”, *The Electr. J.*, vol. 16, no. 10, pp. 39–47, Dec. 2003.
37. L.M. Xia, H.B. Gooi, J. Bai, “A probabilistic reserve with zero-sum settlement scheme”, *IEEE Trans. Power Syst.*, vol. 20, no. 2, pp. 993–1000, May 2005.
38. Ancillary Services Unbundling Electricity Products – An Emerging Market, Report EURO Electric, 2004. (24.05.2017).
39. Settlements & Billing-Configuration Guide for: CG CC 7056 Flexible Ramp Cost Allocation, CAISO, V. 5.3, 2017.