

## Exploring the Mechanisms of Catalyst Synthesis

Elena Vasquez, Lucas Brooks

University of California, Los Angeles, USA

**Abstract** 7KLVVWXG\LQYHVWLJDWHVWKHXVHRIFHQW  
ULIXJDOFDVWLQJ  
PHWKRGRWIDEULFDWHIXQFWLRQDOO\JUDGHGDOXPL  
QLXP\$SOOR\DQG  
\$6L&SFRPSRVLWHIRUK\GURWXUELQHEXFNHWDSOLF  
WLRQ7KH  
VWXG\LQFOXGHVWKHGHVVLJQDQGIDEULFDWLRQRIDS  
HUPDQHQWPRXOG7KH  
PRXOGZDVSWLQWRXVHDQGWKHEXFNHWVRI\$SOOR\D  
QG\$  
6L&SFRPSRVLWHZHUFVDFVWWDQGPDKLQHGQWLV  
SHFLPHQV  
6RPHVSHFLPHQVZHUHJLYHQ7KHDWWUHDWPHQWDQG  
WKHVSHFLPHQV  
ZHUHSUHSUDHUGIRUGLIIHUHQW[DPLQDWLRQVDFFRU  
GLQJO\7KH6L&S  
SDUWLFQHVZHUHIRXQGWREHPRUHDWLQQHUSHULSK  
HURIWKHEXFNHW7KH  
PD[LXPDKDUGQHVVRISV&DVW\$DQGS6L&SFRPSRVLWH  
ZDVUHFVDFVWWDQGWKHEXFNHWVRI\$SOOR\DQ  
G%51  
UHVSHFWLYHO\QGWKHEXFNHWVZHUHDSUHFLDW  
HGWR%51DQG  
%51IRU\$DOOR\DQGS6L&SFRPSRVLWHUHVSHFWLYHO\  
,WZDVREVHUYHGWKDWWKHXOWLPDWHWHQVLOHVW  
UHVVDQGLHOGWHQVLOHVWUHV  
SUHGLFWLRQFXUYHVVKRZWKHVDPHWUHQG

**Keywords** \$DOOR\6L&SFRPSRVLWHFHQWULIXJDO  
FDVWLQJSHOWRQEXFNHWVWXUELQHEODGH

.,1752"8&7,21

9,DOXPLQLXP DOOR\ DQG \$6L&S FRPSRVLWH  
WKURXJK  
1WKLVVWXG\WKHIRFXVLVRQSURSHUWHQKQDQFHP  
HQWRIS  
PDQXIDFWXULQJQDQGWKHEXFNHWVZHUHDSUHFLDW  
XHVIRU3HOWRQEXFNHW  
DSSOLFDFWLRQ7KHVHDFKIRUORFDOO\VRXUFHGPD  
WHULDOVIRU6PDOO  
+GURSRZHU 6+3 WXUELQH FRPSRQHQWV DQG  
V\VVHPV SURGXFWLRQ DQG WKHLU  
PDQXIDFWXULQJ WHFKQRORJLHV LV YHU\  
FULWLFDFWRHQHUVXVWDLQDELQW\Q6XE6DKD  
UDQ\$IUFD66\$ 6+3 WHFKQRORJ\ GRPHVWLFDFWLRQ  
LV WKH NH\ WR WKH SHUHQQLDO  
SRZHUSUREOHPQWKHUHJLRQ  
\$WKHRUHWLFDOPLFURK\GURHOHFWULFSODQWG  
HVLJQIRURIJULG DSSOLFDFWLRQV ZDV FDUULHG  
RXW WR SURGXFH D JUHQ SRZHU IRU  
UHPRWHIDUPVRUFRWWDJH

:LOOLDPV6(EKRWD3K'FDQGLGDWHDQG)UHGGGLH,QDPEDRSV  
VRFLDWH  
SURIHVVRUDUHZLWKWKH8QLYHUVLW\RI.ZD=XOX1DWDQO'XUE  
DQ6RXWK\$IUFD  
SKRQH HPDLO ZLOO\PRRQ#\DKRRFRP  
LQDPEDRI#XN]QDF]D  
7\$%/(  
,,5(9,(

\$ VWXG\ RQ WKH PRGHOOHQJ DQG YDOLGDWLRQ RI  
UHVXOWV HPSLULFDQO\ XVLQJ ORFDOO\  
DYDLODEOH PDWHULDOV LQ .HQ'D ZDV FDUULHG  
RXW >@ ,Q WKH VWXG\ VWUHVU UHGXFWRQ RI  
ZDV DFKLHYHG E\ PRGL\QJ WKH SURLOH RI WKH  
3HOWRQ EXFNHW \$  
UHF\FOHGDQXPLQLXPDOOR\ZDVIRXQGDZDVWRZLV  
KVDQDQ WKH VWUHVVRU 03DSURGXFHGE\  
WKHJHQHUDWHG N:RI SRZHU >@ \$ 3LFR 3HOWRQ  
WXUELQH ZDV GHVLJQHG DQG PDQXIDFWXUH  
XVLQJ FKRSSHG JODVV ILEUHV UHLQIRUFHG HSR[\  
PDWUL] FRPSRVLWH DV WKH EXFNHW PDWHULDO >@  
\$ OLWUH  
FDSDFLW\WVRUDJHWDQNLQDQVWRUH\WRZHUZDVXV  
HGDVDZDWHU VRXUFH WR RSHUDWH WKH  
WXUELQH ,Q WKH VWXG\ N: ZDV JHQHUDWHG RXW  
RI WKH N: WKDW LW ZDV WKHRUHWLFDQO\  
GHVLJQHGIRU,QWKHGHVVLJQVWXG\RIIDYDDQG6LYD  
&\$7,\$ 9 GHVLJQ DQG PRGHOOHQJ VRIWZDUH ZHUH  
XVHG WR GHVLJQ DQ RSWLPLVHG 3HOWRQ  
WXUELQH FRQVLGHULQJ WKUHH PDWHULDOV LQ  
WKH  
DQDO\VLV>@(IILFLHQF\AQGVWUHVVLQHUODWLRQ  
WRWKHQXPEHURI  
EXFNHWVZHUHVWXGLHGQWKHZRUN,QWKHWKU  
HEXFNHWPDWHULDOV VHOHFWHGWHHO FDUULG  
LURQ DQG ILEUJODVV UHLQIRUFHG SODVWL  
PDWUL]WKHVWXG\FRQFOXGHGWKDWILEUJODVV  
UHLQIRUFHGSODVWL  
PDWUL]VKRZVH[FHSLRQDOSHUVRUPDQFHFRPSDUH  
GWRFDVWLURQ  
,WLVREYLRXVWKDWORWRIRUWKHRUHWLFDQO\GU  
RWXUELQHGHVVLJQ  
ZRUNVKDYHEHHQVWXGLHG+RZHYHURQO\OLWUOH  
LVNQRZQZKHQ LW FRPHV WR DOXPLQLXP DOOR\  
DQG WKHLU FRPSRVLWHV IRU WKH  
IDEULFDWLRQRID3HOWRQWXUELQHEXFNHW&RQVL  
GHULQJWKHSUHVHQW DSSOLFDFWLRQ RI  
DOXPLQLXP DOOR\ V DQG WKHLU FRPSRVLWHV  
K\SRWKHWLFDQO\WKLVVWXG\VVHVWKLWJURXSRI

DWHULDOVYHUVWLOH  
LQ3HOWRQWXUELQHEXFNHWSSOLFQDWRQ

*A. Application of A356 Alloy and A356-SiCp Composite Suitability for a Pelton Turbine Bucket*

3UHYLRXV VWXGLHV RIK\GUR WXUELQH  
SODQWV UHYHDOHG WKDW VLOW HURVLRQ  
DIIHFVW WKH XQGHUZDWHU FRPSRQHQWV ZKLFK  
LQFOXGH  
WXUELQHEODGHJUHDW\>@,QVRPHFDVHVZDWHU  
LVVWRUHLQD  
UHVHUYRLURULQDVHWWOLQJEDVLQWREHXVHGZ  
KHQWKHQHGDULVHV  
2YHUSDHULRGRIWLPVHGLPHQWZLWKVLOWDQG  
KDUGDEUDVLYH  
VDQGDVWVHFRPSRQHQWVHWWOHLQWKHUHVH  
UYRLUVRUEDVLQV7KLV SUREOHP PXVW EH  
WDNHQ FDUH RI ZLWK WKH XVH RI VHGLPHQW  
VHWWOLQJ\VVHPVLQSRZHUSODQWV+RZHYHUD  
ORWRXQVHWWOHLQ  
VHGLPHQWSDVVHVWVWKURXJKWXUELQHVHYHU\HD  
UDQGWXUELQHSUDWV DUH H[SRVHG WR VHYHUH  
HURVLRQ 7KLV VHGLPHQW VKRXOG EH  
SUHYHQWHGIURPSDVVLQJWKURXJKWKHWXUELQ  
HELVQFRUSRUDWLQJ WKH VHGLPHQW VHWWOLQJ  
VVVHPV LQ WKH SRZHU SODQW +RZHYHU WKHUH  
DUH VWLOO SRVVLELOLWLHV RI XQVHWWOHLQ  
VHGLPHQW SDVVVLQJ  
WKURXJKWKHWXUELQHDQGWKLVRFXXUHQHFHD  
XVHVHULRXVHURVLRQ  
WRWKHQRI]JOHV\VVHPDQGWKHWXUELQHEODGHE  
XFNHW

*B. Functionally Graded Manufacturing Technique: Centrifugal Casting Technique*

7KH FHQWULIXJDO FVWLQJ WHFKQLTXH ZDV  
FKRVHQ GXH WR LWV PHFKDQLFDO DQG  
PLFURVWUXFWXUDO HQKDQFLQJ DGYDQWJHV  
7KH SURFHVV DLGV PLFURVWUXFWXUH  
JUDGLHQW DQG KDUGQHVV LQ DOOR\V  
HYHQZLWKRXWUHLQIRUFPHQWQGWKHUHIRUH  
JLYHVWKHPDWHULDOD EHWWHU ZHDU DQG  
FRUURVLRQ UHVLVWDQFH >@ 7KH PHFKDQLFDO

SURSHUWLHVRIQXPLQLXP±VLOLFQDOOR\VDUH  
RIWHQLPSURYHGE\ FVWLQJ WHFKQRORJ\ >@  
4XLWH RIWHQ K\SRHXWHFWLF DQG QHUU  
HXWHFWLF\$O6LDOOR\VDUHDSSOLHGZKHQFRUUR  
VLRQUHVLVWDQFHQDQ  
JRRGFVWDELOLW\DUHQHGHGZLWKDVPDODPR  
XQWRI0JDQG&X IRU KHDW WUHDWPHQW  
HQKDQFHQW ,W KDV EHHQ UHYHDOHG WKDW  
FHQWULIXJDOFVWLQJFDQLQFUHDVHUXSWXUHVW  
UDLQEDQ

$$,,,0(7+2^2/2^* < 2)7+(678' <$$

7KHVWXG\LVPHWKRGLFDOO\GLYLGHGLQWRWU  
HHIDEULFDWLQRRI WKH 3HOWRQ WXUELQH  
EXFNHW SHUPDQHQW PRXOG FHQWULIXJDO  
FVWLQJ RI WKH EXFNHW DQG  
FKDUDFWHULVDWLQR RI WKH 3HOWRQ  
WXUELQHEXFNHWPDWHULD

*A. Fabrication of Pelton Turbine Bucket*

7KHIDEULFDWLQRRIWKH3HOWRQWXUELQHEXFN  
HWKDVWZRVWDJHV  
3URGXFWLQRISHUPDQHQWPRXOGDQGFHQWULIXJ  
DOFVWLQJRIWKH  
3HOWRQEXFNHW7KH'PRGHORWKHEXFNHWLVVKRZ  
QLQ)LJ ,Q WKLW VWXG\ WKH EXFNHW ZDV  
GHVLJQHG IRU D FDSDFLW\ RI  
N:WXUELQHSRZHU

3URGXFWLQRIRXOG

7KHPRXOGZDVGHVLJQHGZLWK6ROLGZRUNVVRIW  
ZDUHZKHUH  
WKH,\* (6ILOHVRIWKHPRXOGFRPSRQHQWVZHUHJHQH  
UDWHG7KH SDUWV RI WKH PRXOG ZHUH PDFKLQHG  
DFFRUGLQJ WR WKH VSHFLILFDWLQRV LQ ,QLWDO  
\*UDSKLFV ([FKDQJH 6SHFLILFDWLQRV  
,\* (6ILOHV7KH&\$RIWKHPRXOGDVGHVLJQHGQGSUR  
GXFHG  
DUHVKRZQLQ)LJVDQDQGEUHVSHFWLYHO\

0RXOG0DWHULD

)LJ

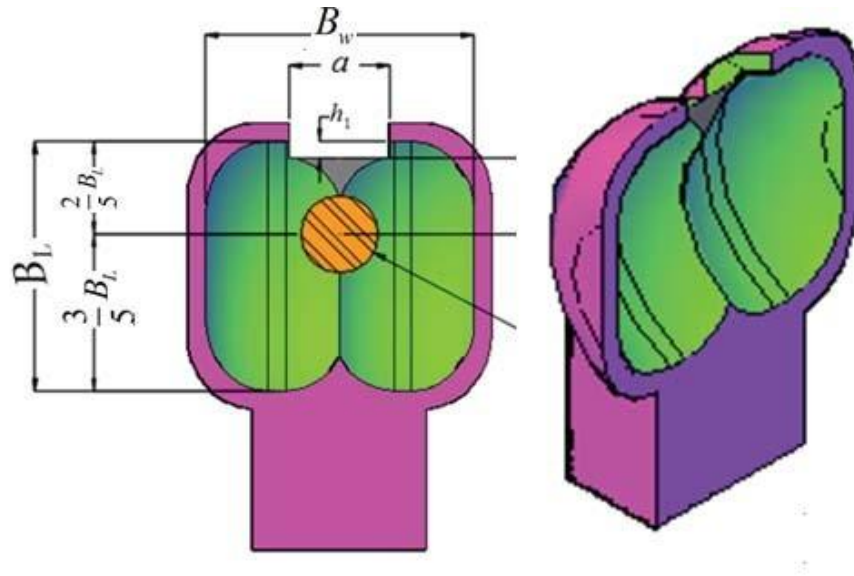

)LJ7KHGHVLJQSDUDPHWHUVRIDEXFNHW

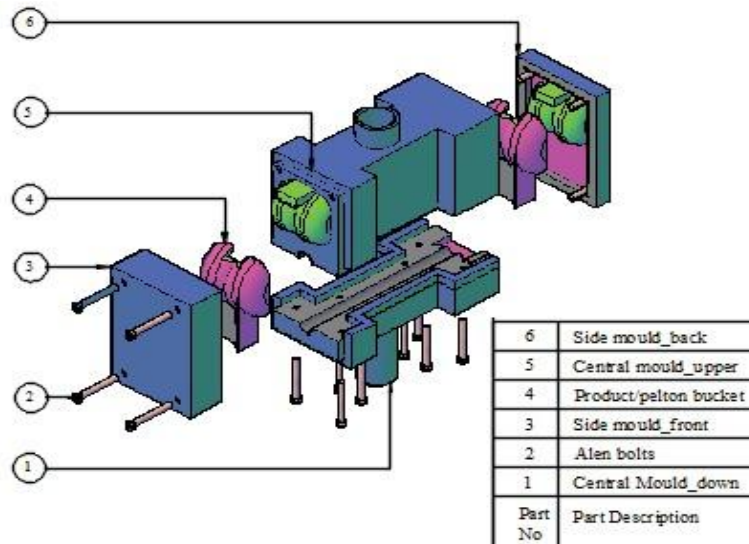

D

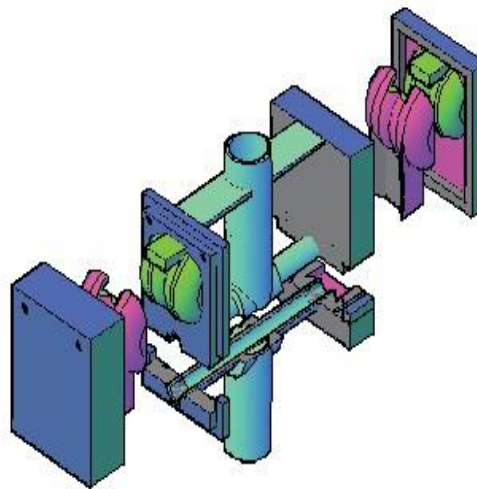

E

)LJD([SORGHGGLDJUDPRIWKH3HOWRQEXFNHWPRXOGDVGHVLJQHGE([SORGHGGLDJUDPRIWKH3HOWRQE  
XFNHWPRXOGDVIDEULFDWHG

$$\frac{7\%/(, \&+(0,\&\$&20326,7,212)7+(2+160\$7(5,\$/86(*)257+(3(721\%8\&.(7028^r}{(OHPHQW \& \quad 0Q \&U : 9}$$

*B. Centrifugal Casting of Pelton Bucket*

7KHFKHPLFDOPRPSRVLWLRQRISXVHGLVVKRZQLQ7DE DGGLWLRQ  
OH

”

$$\frac{7\%/(, \&\$/2<\&+(0,\&\$&20326,7,21}{(OHPHQWV \&X 0J 0Q 6L )H \quad 7L \quad =Q \quad \$O}$$

&DVWLQJRIS\$OOR\

&OD\ JUDSKLWH FUXFLEOH ZDV XVHG WR  
SURFHVV \$ DOOR\  
+H[DFKORURHWKDDQHZDZDSSOLHGDW&IRUGHJDDVVL  
QJRIWKH PROWHQ PHWDO WR SUHYHQW K\GURJHQ  
HQWUDSPHQW 7KH PROWHQ  
PHWDOZDVVXSHUKHDWHGWR□&ZKLFKLVDERYHLW  
VOLTXLGXV WHPSHUDWXUH EHIRUH SRXULQJ LW  
LQWR D VSLQQLQJ PRXOG DQG D VWDWLRQDU\  
UHFWDQJXODU PRXOG IRU JUDYLW\ FVWLQJ 7KH  
3HOWRQ  
EXFNHWSHUPDQHQWPRXOGZDVSUHKHDWHGWR&D  
QGURWDWHG  
DWUSPGXULQJSRXULQJDQGVROLGLILFDWLRQ7KHU  
RWDWLRQ  
ZDVVWRSSHGILYHPLQXWHVDIWHUSRXULQJ

&DVWLQJRIS\$6L&S&RPSRVLWH

7KHVDPHPHOWLQJFRQGLWLRQVIRUWKH\$DOOR\DV  
VWDWHG DERYH ZHUH IROORZHG IRU WKH FVWLQJ  
RI WKH \$6L&s  
FRPSRVLWH7KH□P6L&SDUWLFOHZDVSUHKHDWHG

R□& EHIRUH LQVHUWLQJ LW LQWR WKH \$ PROWHQ  
7KH PL[WXUH ZDV  
VWLUUHGXZLWKDQHOHFWULFPRWRUGULYHQLP SHO  
OHUDWDVSHHGRI  
USP7KHSUWLFOHIIHGUDWHWRWKHPROWHQPHWD  
OLVDERXWJPV DQG WKH VWLUULQJ FRQLQXHV IRU  
PLQXWHV DIWHU WKH SDUWLFOHV



)LJ7KHIDEULFDWHG3HOWRQEXFNHWPRXOGFRPSRQH  
WV

,QWKHPRXOGFRQILJXUDWLRQLWLVGHVLJQHGWRS  
URGXFWZR FVWLQJV LQ RQH RSHUDWLRQ 7KH  
DUUDQJPHQW LV VXFK WKDW WKH  
IDFHVDUHLQWKHVDPHGLUHFWLRQDVGHSLFWHGLQ  
)LJ





7KH KHDW WUHDWPHQW RI \$ FDQ EH FODVVILHG  
LQWR WKUHH EDVHGRQVRDNLQJWHPSHUDWXUHV6RDNLQJDWDK  
LJKWHPSHUDWXUH RI  
&>@>@VRDNLQJWHPSHUDWXUHVOLJKWO\EHORZW  
KH HXWHFWLF WHPSHUDWXUH DW & >@>@ DQG  
WKH VRDNLQJ WHPSHUDWXUH DW & 4XLWH RIWHQ  
K\SRHXWHFWLF DQG QHDU  
HXWHFWLFSO6LDOOR\VDUHDSSOLHGZKHQFRUURVL  
RQUHVLVWDQFHDQG  
JRRGFDVWDELLOW\DUHQHHGHGDQGZLWKDVPDOOT  
XDQWLW\RI0J DQG &X IRU KHDW WUHDWPHQW  
HQKDQFHQHW ,Q FHUWDLQ KHDW WUHDWPHQW  
FRQGLWLRQV DV LQ WKH FDVH RI WKH 7  
WUHDWPHQW RI  
\$\$UHFLSLDWLWRQRI0J6LDQGWKDWWRIVLQFRQRFFX  
U>@

7KH KDUGQHV RI ERWK WKH DOOR\ DQG  
FRPSRVLWH VDPQHV LQFUHDVHG DSSUHFLDEO\  
DIWHU WKH KHDW WUHDWPHQW 0D[LXP  
KDUGQHV DQG %51 IRU WKH DOOR\ DQG  
FRPSRVLWH  
UHVSHFWLYHO\ZDVUHFUGHGWDERXWPPPIURPWK  
HLQQHUIDFH LQ ERWK VDPQHV /HVVHU KDUGQHV  
YDOXH ZHUH UHFUGHG DW  
DERXWPPPIURPWKHLQQHUIDFHLQDOOWKHVDP  
OHV7KLVV  
GXHWRWKHUDSLGVROLGLLFDWLRQDWWKHLQQH  
UVXUIDFHSKULSKHU\  
IDFLOLWDWHGE\FRROLQJFDXVHGE\PRXOGURDWL  
RQ7KHKDUGQHV LQFUHDVH UHFUGHG LV GXH WR  
VXSHUVDWXUDWH VROLG VROXWLRQ  
SURGXFWLRQWKDWRFFXUHGGSULQJWKHVRDNLQ  
JRI\$DOOR\DW  
&IRUIRXUKRXUV7KLVSURFHVVDXVHVWKHGLVVR  
OXWLRQRI KDUGHQHQJ HOHPHQWV0J6L LQ WKH  
PDWUL[ LQWR JOREXODU  
SULPDU\SOVSKHURLGLVDWLRQRIHXWHFWLFLVOLF  
RQDQGFVWLQJ  
KRPRJQLVDWLRQ>@LJVKRZVWKHKDUGQHV  
HQQVLQWKH  
VDPQHV

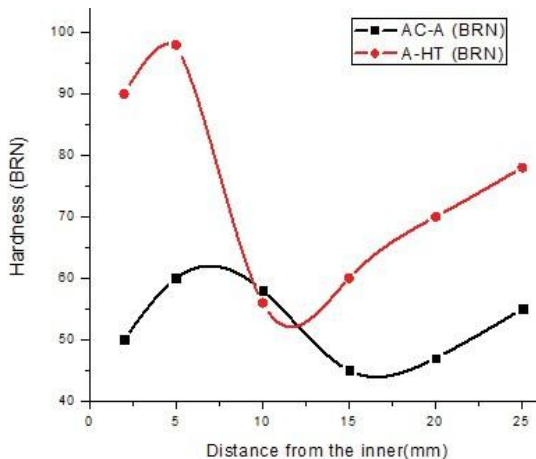

D

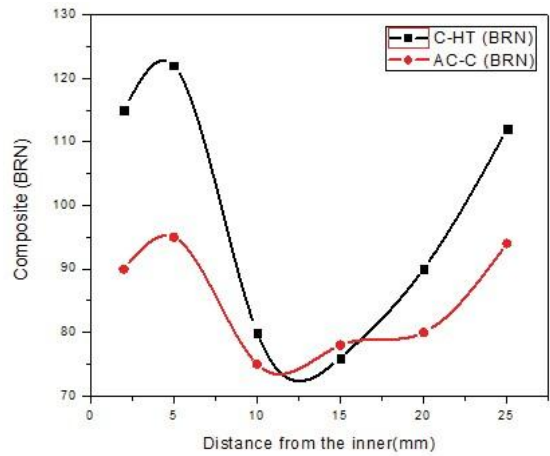

E

)LJ%ULQHOOPLFURKDUGQHVVSORWIRUD\$DOOR\DVFD  
VWDQGHQHW  
WUHDWHGDQGES6L&sDVFDVWDQGHQHWUHDWHGZ  
KHUHS&  
DVFDV\$DOOR\7 \$DOOR\KHDWWUHDWHG&& \$V  
FDVW\$6L&FRPSRVLWH&+7 \$6L&FRPSRVLWH  
KHDWWUHDWHG

7KH GLVVROXWLRQ RI 0J6L  
6SKHURLGLVDWLRQ DQG KRPRJQLVDWLRQ RI  
HXWHFWLF VLQFRQ LQ \$ KDSSHQV ZLWKLQ  
ILYHPLQXWHVVRDNLQJDW&

<LHOG6WUHQJWK<6DQG8OWLPDWH7HQVLOH6WU  
HQJWK876 3UHGLFWLRQV  
7KH VWUHQJWK RI \$7 DQG \$6L&7 FDQ EH

$$YS \ xVHN \ x \quad n$$

ZKHU<6LHOGVWUHQJWK9+1±9LFNHUVKDUGQHV  
QXPEHU  
DQGVWUHQJWKDUGHQHQJH[SRQHQW7KH<6DQG876  
SUHGLFWLRQFXUYHVIRUWKHVDPSOHVDUHVKRZQL  
Q)LJV

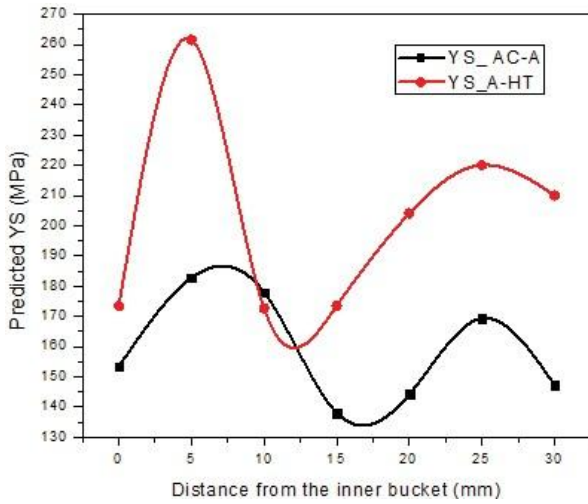

D

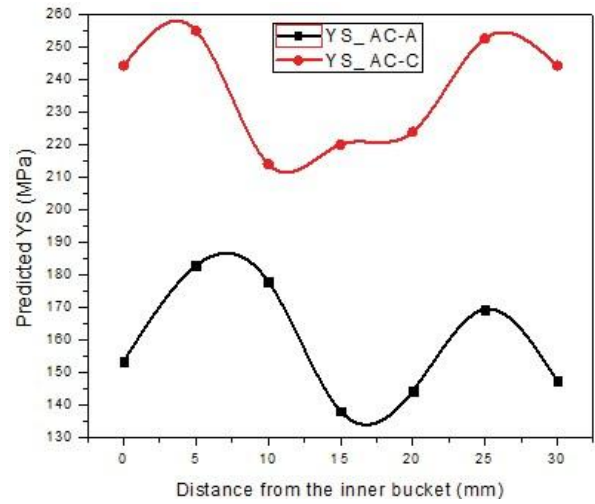

D

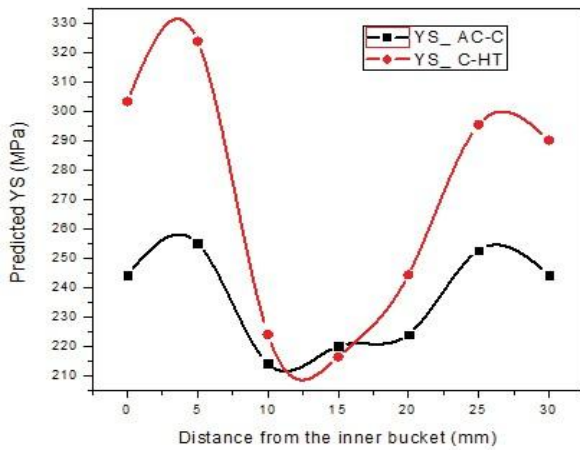

E

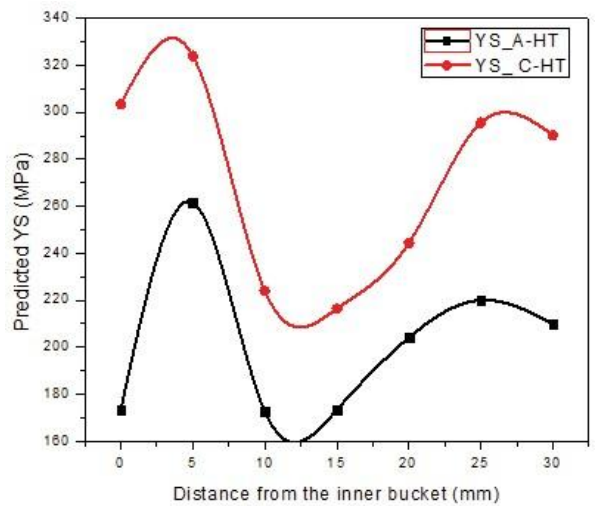

E

)LJ<LHOGVWUHQJWKSUHGFLWLRQRID\$DVFDVW<6B\$&\$DQG  
KHDWWUHDWHG<6B\$&+7DQGE\$6L&SDVFDVW<6B\$&DQG

)LJ<LHOGVWUHQJWKSUHGFLWLRQRID\$DVFDVW<6B\$&\$DQG

KHDWWUHDWHG<6B\$&+7

\$6L&sDVFDVW<6B\$&DQGE\$KHDWWUHDWHG<6B\$&+7

DQG\$6L&sKHDWWUHDWHG<6B\$&+7

\$JDLQ WKH <6876 UDWLR FDQ EH SUHGFLWHG LQ WHUPV RI Q XVLQJDQG

$$YS \frac{UTS}{a-n} \exp n^{\delta/4} n_n$$

$$UTS \frac{YS n_n}{a \exp n^{\delta/4}}$$

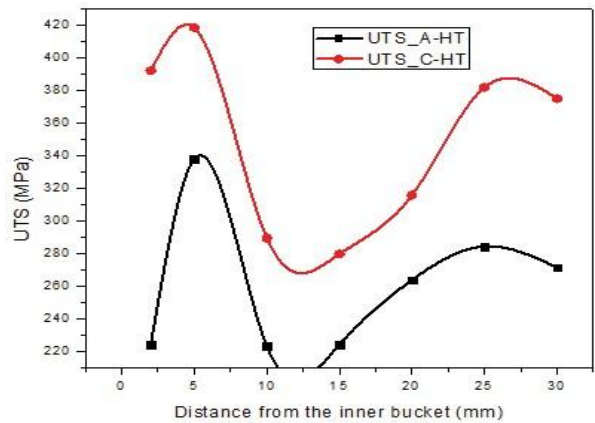

)LJ876SUHGLFWLRQRIKHDWWUHDWHGD\$876BS+7DQG  
\$6L&s876B&+7

)URP)LJVLWZDVREHVUYHGWKDWWKH<6DQG876  
DSSUHFLDWHGJUHDWO\DFURVVWKHVXUIDFHIRUER  
WK\$DOOR\DQG  
\$6L&sFRPSRVLWHVVDIWHUKHDWWUHDWPHQW

7KH DXWKRUV KHUHE\ DFNQRZOHGJH WKH  
&HQWUH IRU (QJLQHHLQJ 3RVWJUDGXDWH  
6WXGLHV PDQDJPHQW DQG VWDII RI  
WKH8QLYHUVLW\RI.ZD=XOX1DWDO

93527(&7,9(&2\$7,1\*2)3(/721%8&.(7

5)(5(1&(6

'HVSLWHWKHZHDUDQGFRUURVLRQUHVLVWDQFH  
RIWKH\$DOOR\ DQG \$6L&s FRPSRVLWH WKH\ DUH  
VWLOO YHU\ PXXFK  
VXVFHSHWLEOHWRVHDZDWHUFRUURVLRQDQGVLO  
WHURVLRQRYHUWLPH )RU EHWWHU RSHUDWLRQ  
SHUIRUPDQFH DQG OLIHVSDQ FRDWLQJ WKH  
EXFNHW\VLQQUHVVXUIDFHZLWKWRXJKHUDQGGKDU  
GHQHGPDWHULDOLV UHFRPPHQGHG &RDWLQJ WKH  
WXUELQH ZLWK FHUPLF LV FRPPRQ  
DQGHIIHFWLYHGXHWRWKHSURYLVLRQRIWKHIROO  
RZLQJ SURWHFWLYH  
VHUYLFHWKHWXUELQHVXUIDFH:HDUDQGFRUU  
RVLRSURWHFWLRQ LPSLQJPHQW SURWHFWLRQ  
VLOW HURVLRQ SURWHFWLRQ DQG VXUIDFH  
KDUGQHV LPSURYHPPHQW 7KLV VWXG\  
UHFRPPHQGV D FHUPLF FRDWLQJ RI \$O2  
LPSODQWHG )H PLFURJUDLQV DQG PLFURDUF  
R[LGDWLRQ\$2RUSODVPHOHFWURO\WLFRLGDWL  
RQ3(2

: 6 (EKRD \$ & (ORND(ERND DQG ) / ,QDPEDR (QUJ  
VXVWDLQDELOLW\WKURXJKGRPHVWLFDWLRQRIHQHUJ\WHF  
KQRORJLHVLRQWKLUG ZRUGFRXQWULHVLRQ\$IUFLDQ  
*Industrial and Commercial Use of Energy (ICUE), 2014 International  
Conference on the "Energy efficiency in buildings".SS*  
:6(EKRD

) ,QDPEDR(OHFWULFVLW\LVXIIILFHQFVLQ\$IUFLD  
\$SURGXFWRILQDGHDXDHPDQXIDFWXULQJFDSDFLW\$IUFLD  
Q-RXUQDORI  
6FLHQFH7HFQRORJ\,QQRVWDLRQDQGHYHORSHPHQWYROSS  
+/LX'0DVHUDDQG/(VVHU:RUOG+GURSRZHU'HYHORSHPHQW  
5HSRUW8QLWHLG1DWLRQ,QGXVWULDO'HYHORSHPHQW2UJDQLV  
DWLRQ  
81,2DQG,QWHUWLRQDO&HQWUHRQ6PDOO+\GURSRZHU,&6+3  
\*RLFHDQO,JQDWLR(IILFLHQF\,PSURYHPPHQWRI3HOWRQ:KHH  
ODQG &URVVORZ 7XUELQHV LQ 0LFUR+\GUR 3RZHU 3ODQV  
&DVH 6WXG\ *International Journal of Engineering and Computer Science  
YROSS*

%:LOOLDP69DVXDQ60DQMRW\*UHHQ0HFKDWURQLFV3URMH  
FW3HOWRQ  
:KHHO'ULYHQ0LFUR+\GUR3ODQW0HFKDQLFDO(QJLQHHLQJ8Q  
LYHUVLW\RI2WWDZD  
5 1 0ELX 6 0 DUDQJD DQG + 1GLULWX 3HUIRUPDQFH RI  
\$OXPLQLXP\$SOOR\%DVHG%XFNHVW7RZDUGV%HQGLQJ)RUFH  
VRQ 3HOWRQ 7XUELQHV LQ *Sustainable Research and Innovation  
(SRI) Conference*1DLUREL.HQ'DSS  
,\$.0.KDELUXO%6DKQHZD]DQGS&DURRTXHSGYDQFHG  
&RPSRVLWH 3HOWRQ :KHHO 'HVLQJ DQG 6WXG\ LWV  
3HUIRUPDQFH IRU  
3LFR0LFUR+\GUR3RZHU3ODQW\$SSOLFVWLRQ *International  
Journal of Engineering and Innovative Technology (JEIT), YROSS*

1,51DYDDQG763UDVDG'HVLJQDQ6WDWLF\$QDO\VLVRI3HOWR  
Q 7XUELQH%XFNHVW *International Journal of Science Technology and  
Management, YROSS*  
\$&9LHLUD3'6HTXHLUD-5\*RPHVDQ6\$5RFKD'U'60LGLQJ  
:HDURISO\$OOR\6L&S)XQFWLRQDOO\*\UDGHG&RPSRVLWHV,QIO  
XHQFHRI 3URFHVVLRQJ&RQGLWLRQV *Wear YROSS±*  
E\ 0HDQV RI 4XDOLW\ ,QH] DQG 3UREDEOH <LHOG  
6WUHQJWK *AFS International Cast Metals Research Journal,  
YROSS*  
7RXJKQHVVLRQ\$O6LDQ6\$O6L&X&DVW\$OORV3DUW,(IIFW  
RI  
3URFHVV9DULDEOHVDQ60LFURVWUXFWXUH *International  
Journal of Impact Engineering, YROSS*  
SS

9,&21&/86,21

7KLVVWXG\FRQFOXGHVWKDW  
L 7RJHQXLQHO\WXUQDURXQGWKHSUHQQLDOSR  
ZHULVXHVLRQ  
66\$SRZHUVRXOGEHJHQHUDWHGIURPWKHDEXQ  
GDQWVWVDOO K\GUR SRWHQWLDQV ZLWK WKH  
DSSOLFVWLRQ RI LQGLJHQRXV  
WHFKQRORJ\DQGPDWLUDOV  
LL 8VH RI FHQWULIXJDO FVWLQJ PHWKRQ DQG  
KHDW WUHDWPHQW  
LPSURYHGKHPFKDQLFDOSURSHUWLHVRIWK  
H\$DOOR\DQG \$6L&s FRPSRVLWH PDNLQJ WKHP  
PRUH VXLWDEOH IRU  
3HOWRQEXFNHW\$SSOLFVWLRQ  
LLL +HDWWUHDWHG\$DOOR\DQGS6L&sFRPSRVLWHZL  
OO EH VXLWDEOH IRU WXUELQH PDWHULDQV  
IRU D ZDWHU VWRUDJH  
WXUELQH\VVHP7KLVLVGXHWRWKHPQLPDOS  
HUFHQWJHRI VLOW LQ WKH VWRUHG ZDWHU  
DQG WKH HQKDQFHG FRUURVLRQ DQG  
ZHUUHVLRQDQFH SURSHUWLHVRIWKHPDWHU  
LDQV  
LY 7R IXUWKHU LPSURYH WKH OLIH VSDQ RI WKH  
EXFNHW KDUG  
VXUIDFHFRDWLQJVKRXOGEH\$SSOLHG

\$&.12:/(\*(0(176