

Optimization of Advanced Suspension Systems

E. Raghavendra, A. K. Sahil, P. Nalini

National Institute of Automotive Technology, Bengaluru, India

Abstract—In the process to cope with the challenges faced by the automobile industry in providing ride comfort, the electronics and control systems play a vital role. The control systems in an automobile monitor various parameters, controls the performances of the systems, thereby providing better handling characteristics. The automobile suspension system is one of the main systems that ensure the safety, stability and comfort of the passengers. The system is solely responsible for the isolation of the entire automobile from harmful road vibrations. Thus, integration of the control systems in the automobile suspension system would enhance its performance. The diverse road conditions of India demand the need of an efficient suspension system which can provide optimum ride comfort in all road conditions. For any passenger vehicle, the design of the suspension system plays a very important role in assuring the ride comfort and handling characteristics. In recent years, the air suspension system is preferred over the conventional suspension systems to ensure ride comfort. In this article, the ride comfort of the adaptive suspension system is compared with that of the passive suspension system. The schema is created in MATLAB/Simulink environment. The system is controlled by a proportional integral differential controller. Tuning of the controller was done with the Particle Swarm Optimization (PSO) algorithm, since it suited the problem best. Ziegler-Nichols and Modified Ziegler-Nichols tuning methods were also tried and compared. Both the static responses and dynamic responses of the systems were calculated. Various random road profiles as per ISO 8608 standard are modelled in the MATLAB environment and their responses plotted. Open-loop and closed loop responses of the random roads, various bumps and pot holes are also plotted. The simulation results of the proposed design are compared with the available passive suspension system. The obtained results show that the proposed adaptive suspension system is efficient in controlling the maximum over shoot and the settling time of the system is reduced enormously.

Keywords—Automobile suspension, MATLAB, control system, PID, PSO.

I. INTRODUCTION

IN the automobile sector, the term ride comfort is defined as the transportation of an automobile passenger in such an easy a manner that the trip will be a pleasure and not a hardship [1]. A survey among 20,000 car owners revealed that their interest on ride comfort stands third after endurance and economy of operation. Numerous researchers proposed various suspension systems to improve ride comfort. In 1933, Broulhet [2] surveyed the various proposals of independent

wheel suspensions. His experiments lead to the conclusion that the automobile can be driven on the modern roads without it experiencing any kind of vibration. Maurice Olley claims that the

motion of a car is never the true picture of the road surfaces but is generated by the car frequencies excited by that road surface [3]. He took into account the main frequency, tire frequency and unsprung mass frequency to analyze the comfort in an independent suspension system. The analysis might have been enough to predict the degree of comfort but the authors failed to consider various types of road surfaces. The three sources of disturbances are ride, controllability and noise and vibration [4]. To optimize the performance of the vehicles, it is necessary to compare the ride characteristics of various cars and determine the changes required to be made to enhance the performance. Observation, experimental and mathematical analysis are three effective ways of analysis of any system.

A suspension system is employed basically to isolate the vehicle from the road irregularities and provide a comfortable ride for passengers. The conventional suspension systems used in most of passenger vehicles are passive; leaf springs being the most commonly employed. Even though the leaf springs proved themselves to be strong and apt for suspension systems, they experienced failure in various conditions. The design and metallurgical reasons for fracture of leaf springs were found to be the major reasons for failure [5]; it was determined that the fracture initiated from the center hole of the leaf spring. Energy based on the variational method was found effective to analyze the geometric nonlinearity of uniform leaf springs considering the effect of material property variations [6] by adapting updated Lagrangian analysis. The fatigue life and damage calculation under variable amplitude loading was evaluated using two different mean stress correction factors, Morrow and SWT [7]. The Finite element analysis results often deviate from the experimental and theoretical values. The test rig results and FE analysis results of Z-type leaf springs were compared [8] and a correlated FE model and damage analysis methodology is coined which can be used for test specifications and verifications of the same. Even though the semi-elliptical leaves were used extensively, various researches were carried out on other designs to replace it.

The attempt to replace the passive suspension systems with active and semi-active systems was popular among the researchers. In the late 1980's and early 1990's, extensive researches on active and semi-active suspension systems were done. That was the era of luxury cars. Surveys were done on the application of optimal control techniques in suspension systems, extensively on active suspension systems [9]. The survey showed that active suspension systems have a potential to improve ride quality and handling characteristics. The various parameters that are responsible for ride discomfort were discussed and dynamic analysis and uncertainty analysis were performed on a one dimensional quarter-car model with 2 degrees of freedom with the software FAMOUS based on fuzzy arithmetic [10]. These analyses gave a better picture of the intensity of vibrations caused

by body mass, body spring tension, shock absorber, wheel mass, and tire spring tension. The scope of vibration control in automobile was vast that various experiments were performed. Experiments on active seat suspension proved its efficiency [11].

Various controllers and control algorithms were extensively used in active and semi-active suspension systems. A few of them were successful but were not practical enough to be implemented in a passenger vehicle. Air springs were proven to be more effective in providing ride comfort to the passengers in passenger vehicles. Many researches were conducted in an attempt to control the stiffness of the air springs. A new analysis method was proposed to optimize the air spring characteristics and the bush dynamic characteristics and thus balance ride comfort, handling and stability [12]. The various equations of continuity, energy and state of gas were checked for the air spring, pipe and auxiliary chamber. After the experiments the results showed that the diameter of the orifice has an effect on the resonant frequency. The design of air springs has a major role in their efficiency. The geometry of structures of the air springs and the characters of changing shape in an air spring were examined [13]. The changing volume of the air spring was obtained by using numerical calculations and the relationship curve between the applied force on the air spring and the displacement of the air spring were obtained. The methods used for obtaining the non-linear mechanical properties of the air spring were practical and effective. Based on their previous research, Hostens et al. [14] proposed a new improved passive suspension system with additional air volume and variable damping. The advantages and disadvantages of the air springs with additional air volumes were discussed and it was concluded that they provide higher improved ride comfort, but they are difficult in packaging under the seat. A dynamic model was created to estimate the dynamic characteristics of the vehicle [15]. Based on the experiments, it was found that, the non-linearity of the pressure receiving area should be considered during large displacements. At lower frequencies, the dynamic stiffness of the air spring is almost equal to the stiffness without orifice and the damping characteristics are neither viscous nor quadratic but proportional to the velocity exponent. Air springs provide change in stiffness coefficient by varying the volume and thus provide a controlled variable spring rate. The dynamic and mathematical air spring models were done and were analyzed [16]. OptiY SIMULINK was used to optimize the parameters to model an air spring [17]. The results show that the results obtained are similar to that of a passive system.

In this study, we have observed that the air springs provide a more comfortable ride and an active suspension system can provide better handling characteristics. Thus, an adaptive air suspension system is the solution for providing better ride comfort for passengers.

II. METHODOLOGY

A. Mathematical Modelling

A quarter-car model, as shown in Fig. 1, is considered for the problem. It is assumed that, the quarter-car model has exactly one fourth of the complete mass of the vehicle. For convenience of analysis, the pitch and the roll angles are considered to be very less. The suspension system is modelled as a linear spring with a

damper. The tire is modelled as a linear spring with damping. The rotational motion of the wheel is neglected. The tire is considered to be always in contact with the road surface.

The equations of motion for the sprung and unsprung masses are given as [18]:

$$\ddot{x}_1 + \frac{c_a}{m_s} \dot{x}_1 + \frac{k_a}{m_s} x_1 = \frac{c_u}{m_s} \dot{x}_2 + \frac{k_u}{m_s} x_2 + \ddot{z} \quad (1)$$

$$\ddot{x}_2 + \frac{c_u}{m_u} \dot{x}_2 + \frac{k_u}{m_u} x_2 = \ddot{z} \quad (2)$$

TABLE I
STATE VARIABLES AND VALUES

Parameter	Description	Values
m_s	Mass of the car body	221 Kg
m_t	Mass of the tyre	31 Kg
c_a	Damping of spring	600 N/m/s
c_t	Damping of tyre	1118 N/m/s
k_a	Stiffness of spring	14230 N/m
k_t	Stiffness of the tyre	122500 N/m
x_1	Displacement of the car body	To be determined
x_2	Displacement of the tyre	To be determined
z	Road disturbance	0.1m step input
u_a	Force of hydraulic actuator	

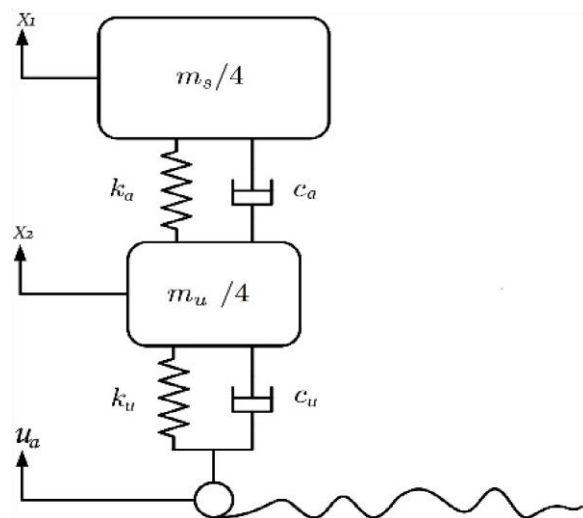

Fig. 1 Quarter-car vehicle suspension model

B. PID Controller Design

The Proportional Integral and Derivative (PID) controller works on the feedback loop system. The system considered in this paper is a Multiple Input Multiple Output (MIMO) system since the vehicle may be subjected to various amplitudes of loads from various road conditions. Thus, the open-loop response of the system is obtained, as shown in Fig. 2. The control input is obtained as follows:

$$U(s) = \frac{e(s)}{G(s)} \quad (3)$$

where, K_p , T_i and T_d are proportionality constant, integral time and derivative time and $e(t)$ is the error.

of the system cannot be predicted accurately. The main purpose of the Bode plot is to verify the stability of the system. Thus, the tuning is done in such a way to assure the stability of the system. The obtained values from the Bode plot are:

- Critical Gain $K_{cr} = 11.2$ dB
- Critical frequency $\omega_c = 0.407$ Hz
- Critical period $P_{cr} = 2\pi/\omega_{cr} = 15.437$

The Ziegler-Nichols tuning is shown in Table II and Table III [18]:

TABLE II
ZIEGLER-NICHOLS TUNING

Type of Controller	K_p	T_i	T_d
P	$0.5K_{cr}$	∞	
PI	$0.45K_{cr}$	$0.83P_{cr}$	
PID	$0.6K_{cr}$	$0.5P_{cr}$	$0.125P_{cr}$

TABLE III
ZIEGLER-NICHOLS TUNING VALUES

Type of Controller	K_p	T_i	T_d
P	1.815	∞	0
PI	1.452	12.8127	0
PID	2.178	7.7185	2.00681

Fig. 3 Bode plot of the presented open-loop system

C. PID Controller Tuning

The controller tuning is one of the most tedious processes in the control system. For a given system, the open-loop response is obtained from MATLAB. The response clearly portrays the maximum overshoot, settling time of the oscillations due to the load and displacement of the system. The main focus in this research will be to reduce the displacement, overshoot and minimize the settling time so that the passengers experience no discomfort due to any kind of external loads. For an ideal system, the Bode plot is shown in Fig. 3, and the required critical gain and critical frequency values for the particular system are obtained. The Ziegler-Nichols tuning system is the most common tuning system used.

From the Bode plot, the gain margins and phase margins are obtained. These margins are much needed, because the behaviour

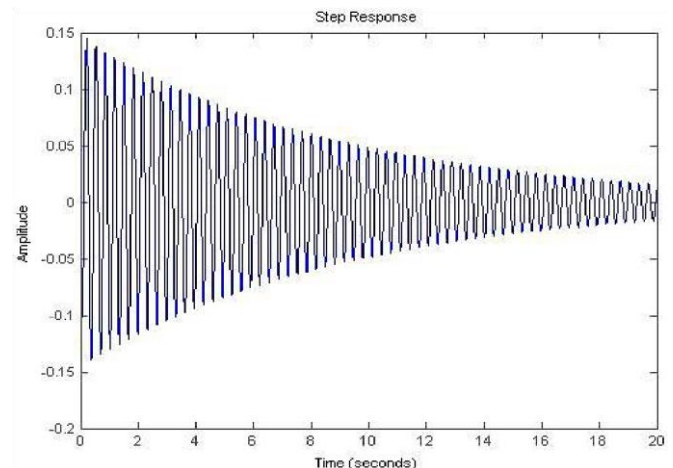

Fig. 4 Closed-loop response of the system after tuning

TABLE IV
MODIFIED ZIEGLER-NICHOLS TUNING

Controller Parameters	K_p	T_i	T_d
Some Overshoot	$0.33K_{cr}$	$P_{cr}/2$	$P_{cr}/3$
No Overshoot	$0.2K_{cr}$	$P_{cr}/2$	$P_{cr}/3$

Thus, based on Ziegler-Nichols tuning, for this system, $K_p = 1.1979$, $T_i = 7.7185$, $T_d = 2.5728$

Even though this method is simple, since it does not require a process model, this method is restricted to processes that are

of marginal stability, as observed in Fig. 5. For processes with correspondingly large overshoots and undesirable set point changes, a more conservative method is used; that is, the modified Ziegler-Nichols tuning technique (Table IV). However, neither of the above methods provides efficient results. The reason is the complexity of the system. The differential equation is of fourth order and when such higher order equations of motion are dealt, genetic algorithms provide better and accurate results. Thus, PSO is used [19]. It is a computational method that optimizes a problem by iteratively trying to improve the solution with regard to the expected quality; 500 to 20000 iterations were carried out,

obtaining optimal control, manual tuning of the gain values will be recommended by the authors. The PSO is time consuming and practically tiring process for complex systems of multiple input and multiple output. It is obtained that $K_p = 20060.175$, $K_i = 12800.97$, $K_d = 100500.8$.

Fig. 6 Closed-loop response of the system after effective tuning

A Simulink model of the system is presented in Fig. 8. The presented model clearly describes the adaptive suspension system. The Simulink model of the PID controller is also shown in Fig. 9.

B. Road Profiles and Disturbances

standards are taken. The standards vary from Class A to Class H. Since the road profiles at various regions cannot be predicted in advance, the uncertainty of the profiles is presented in the ISO

A	–	–
B	32	
C	128	
D	512	
E	2048	
F	8192	32768
G	32768	131072
H	131072	–
	$n_0=0.1$ cycles/m	$\Omega_0=1$ rad/m

standards. In the road models, power spectral density has been used to describe the properties of random data [20].

C. MATLAB Simulation

The basic differential equations are simplified into state space equations so that they can be used in the MATLAB schema for simulation. The required closed-loop responses of the system for random road profiles and provided disturbances were obtained.

IV. RESULTS AND DISCUSSION

The simulations of the system, considering various road profiles and disturbances show that PSO algorithms are better suited for the MIMO system. Basic tuning methodologies such as Ziegler-Nichols tuning method or modified Ziegler-Nichols tuning method prove to be less efficient than the PSO algorithm. These tunings would be helpful in Single Input Single Output (SISO) systems.

The closed-loop response with the Zeigler-Nichols tuning, as shown in Fig. 4, depicts an unexpected overshoot, worse than the open-loop. This behaviour is observed because of the complexity of the system as well as the loading conditions. A quarter consists of two masses, a suspension and a tire which is constantly in contact with the road surface. Such complexity is not dealt with in the Zeigler-Nichols method.

Again, the modified Zeigler-Nichols method shows a reduced overshoot compared with that of Zeigler-Nichols tuning method, as seen in Fig. 6, but is still way too high compared with the expected response. The aim of this research is to reduce the overshoot and bring down the displacement which is clearly not satisfied by both the above tuning methods.

To control such complex systems, the controller needs competitive and efficient tuning method. The PSO is one competitive method. It can be observed in Fig. 7 that, the overshoot is vastly reduced by the controller which is tuned by the PSO algorithm. When the same is applied for the ISO 8608 standard random road profiles, the displacement and overshoot of the system is vastly reduced, as can be seen in Figs. 11 (a) and (b). Still, the users may observe that the system never settles completely. Also, the genetic algorithms take too much time for the iterations which is a practical difficulty.

Keeping the iterative time constraint aside, the PSO proves efficient in controlling the system. The random road outputs are the proof that the controller can be efficient in any kind of roads. The dynamic loading response and the controlled responses of seven classes of random roads are plotted. Class A refers to a good road, gradually reducing to Class G, which refers to the worst road. The roads are classified good, medium and worst based on their surface irregularities.

The comparative results, as seen in Table VI, show that an adaptive system can be more efficient in providing ride comfort and control characteristics. The overall displacement can be reduced and unwanted vibrations can be damped efficiently by the system. The settling time of the entire system has also improved enormously proving, the adaptive system is more efficient and suitable for every road condition.

COMPARATIVE RESULTS OF PASSIVE AND ADAPTIVE SYSTEMS

Parameter	Passive System	Adaptive System	Improvement
Displacement (m)	0.019	0.0036	88.23%
Peak (m)	0.164	0.00236	98.4%

TABLE VI

Even though the PSO algorithm proved efficient, the computational complexity is too high while solving complex problems, which results in the huge time consumption. For efficient operation and optimal results, one must opt for manual tuning which is a trial and error method. The simulation results clearly show that, an adaptive system can be very efficient in reducing the displacement and thereby providing better ride comfort to the passengers. Also, the tuning methodologies are restricted for simple single input single output systems only. For complex systems with multiple inputs and multiple outputs, we suggest manual tuning is efficient. Manual tuning is both practical and time efficient. Also, when the simulation results are

applied for a practical implementations, to ensure the safety of the system, manual tuning is preferred.

REFERENCES

- [1] Hess, S., "Automobile Riding-Comfort" SAE Transactions, 1924.
- [2] Bodeau, A., Bollinger, R., and Lipkin, L., "Passenger-Car Suspension Analysis" SAE Transactions, Vol. 64, 1956.
- [3] J.J. Fuentes, H.J. Aguilar, J.A. Rodri'Guez, E.J. Herrera, "Premature Fracture In Automobile Leaf Springs", Engineering Failure Analysis 16 (2009) 648–655.
- [4] Dipendra Kumar Roy And Kashi Nath Saha, "Nonlinear Analysis Of Leaf Springs Of Functionally Graded Materials", Procedia Engineering 51 (2013) 538 – 543
- [5] Y.S. Kong, M.Z. Omar, L.B. Chua, S. Abdullah, "Fatigue Life Prediction Of Parabolic Leaf Spring Under Various Road Conditions", Engineering Failure Analysis 46 (2014) 92–103.
- [6] Mahmut Durus, Levent Kirkayak, Aykut Ceyhan, Kagan Koza, "Fatigue Life Prediction of Z Type Leaf Spring and New Approach to Verification Method", Procedia Engineering 101 (2015) 143 – 150.
- [7] D. Hrovat, "Survey of Advanced Suspension Developments and Related Optimal Control Applications", Automatica, Vol.33, No. 10, 1997.
- [8] Werner Schiehlen, Igor Iroz, "Uncertainties in Road Vehicle Suspensions", Procedia IUTAM 13 (2015) 151 – 159.
- [9] Zengkang Gan, Andrew J. Hillis, Jocelyn Darling, "Adaptive Control of an Active Seat for Occupant Vibration Reduction", Journal of Sound and Vibration 349 (2015) 39–55.
- [10] Katsuya Toyofuku, Chuuji Yamada, Toshiharu Kagawa, Toshinori Fujita, "Study on dynamic characteristic analysis of air spring with auxiliary chamber", JSAE Review 20 (1999) 349}355.
- [11] Ouyang Qing and Shi Yin, "The Nonlinear Mechanical Properties of an Airspring", Mechanical Systems and Signal Processing (2003) 17(3), 705–711.
- [12] I. Hostens, K. Deprez, H. Ramon, "An Improved Design of Air Suspension for Seats of Mobile Agricultural Machines", Journal of Sound and Vibration 276 (2004) 141–156.
- [13] Feng-Xiang Lia, Wei-Min Yang and Yu-Mei Ding, "Simulation of Static Test of Air-spring", Advanced Materials Research Vols 11-12 (2006) pp 713-716.
- [14] Viktor Gavriloski, Jovana Jovanova, Goce Tasevski, Marjan Djidrov, "Development of a New Air Spring Dynamic Model", 2014 FME Transactions, Vol 42, 305 – 310.
- [15] Haider J. Abid, Jie Chen, and Ameen A. Nassar, "Equivalent Air Spring Suspension Model for Quarter-Passive Model of Passenger Vehicles", Hindawi Publishing Corporation, International Scholarly Research Notices, Volume 2015, Article ID 974020.
- [16] Senthilkumar Mouleeswaran, "Design and Development of PID Controller Based Active Suspension System for Automobiles", PID Controller Design Approaches – Theory, Tuning and Application to Frontier Areas, ISBN 978-953-51-0405-6, 2012.
- [17] Wissam H. Al-Mutar, Turki Y. Abdalla, "Quarter-car Active Suspension System Control Using PID Controller Tuned by PSO", Iraq J. Electrical and Electronic Engineering, Vol. 11, No. 2, 2015.
- [18] The Vibrations Induced by Surface irregularities in road pavements – a 6.