

# Optimization of Advanced Power Conversion Systems

**Dr. Rohan K. Patel, Prof. Shreyas R. Desai**  
*Indian Institute of Technology Bombay, Mumbai, India*

## ABSTRACT

The paper presents a special function improved Flyback converter is operate with better efficiency and compact size, which is prevail over most of the basic flyback converter downsides, and also keeping its inexpensiveness and lucidity. In certain, the converter permits the MOSFET OFF voltage to be less in amount and clamped to the input, thus healing the transformer leakage energy. As a result of effect, the duty cycle can be increase to unity, thus reducing the voltage stress across the output rectifier, and minimizing both the magnetizing inductance and the transformer bias current values. Moreover, to the auxiliary mosfet, the magnetizing current will negative, abolish the discontinuous conduction mode (DCM) of the basic Flyback and permits a smaller magnetizing inductance is to be selected. Besides, in contrast with the basic Flyback, the energy is supplied to the secondary side not only from the magnetizing inductance, but also from the introduced series capacitor, minimizing the transformer energy necessity. The improved converter makes also the soft-transitions possible for both mosfet. For all these reasons, as a more effective and compact size approximate, this topology shows better fulfillments in high power density inexpensive applications. This paper also presents practical design deliberation of high frequency transformers for flyback converters hiring High Frequency Transformer (HFT). In order to give insight to the reader, practical design examples are also provided.

**KEYWORDS:** Flyback Converter, discontinuous conduction mode (DCM), High Frequency Transformer (HFT)

## 1. INTRODUCTION

Nowadays, due to its simplicity, low parts count and low cost, the Flyback converter is widely used [1-2]. However, the voltage stress across the switch is high for this topology and it becomes higher and higher when the duty-cycle approaches unity. As a consequence, it is a challenge for the conventional Flyback to operate at an high duty-cycle value, with benefits on lowered voltage stress across the output rectifier, and reduced magnetizing inductance and transformer bias current values. Moreover, the transformer leakage energy generates a voltage spike across the mosfet, whose amplitude could cause its failure [3-5]. The greater the output power is, the larger the energy stored in the leakage inductance and the spike across the mosfet, thus limiting the maximum converter power. Furthermore, the mosfet in the Flyback converter is hard switched. Finally, in case of CCM operation, a lower limit is given to the magnetizing inductance [6]. All these issues greatly limit the efficiency of the converter, making it just suitable for very low-power applications.

In order to overcome these drawbacks this paper presents an higher efficiency, smaller size Flyback converter approach which employs an auxiliary switch and a capacitor in series to the primary windings. The new converter still keeps low part count and simplicity. The benefits introduced greatly overcome the slightly added complexity. By the means of the auxiliary switch and the series capacitor, the voltage across the mosfet is reduced and clamped to the input, and its value does no longer depend on duty-cycle. The output power can be thus increased and the duty cycle can be extended to unity, lowering the energy stored in the transformer and the voltage stress across the output diode, and allowing a smaller magnetizing inductance value to be selected for a fixed magnetizing current ripple. Furthermore, the auxiliary switch provides a current path for the magnetizing current to invert its direction during the converter OFF state, eliminating the discontinuous conduction mode of the conventional Flyback. Thereby, for the CCM operation, there is no longer the need to provide a minimum magnetizing inductance value to avoid the DCM operation. The introduced elements make it also possible to use the transformer leakage energy to fully remove the output capacitance mosfet energy and achieve zero voltage transitions (ZVT). All these issues make the improved converter a smaller and higher efficiency converter.

## 2. THE CONVERTER TOPOLOGY

Fig. 1 shows the improved Flyback converter topology. In comparison with the basic Flyback, a capacitor CS is added in series to the primary windings, and an additional switch is placed in parallel to said series connection.

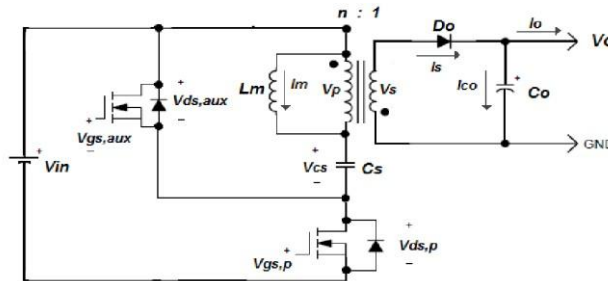

Fig. 1: Implemented Flyback converter

By the means of the auxiliary switch and the series capacitor, the voltage across the mosfet is reduced and clamped to the input, and its value does no longer depend on duty-cycle. The auxiliary switch conducts during the entire primary mosfet OFF period, allowing the two mosfet to switch on and off alternatively.

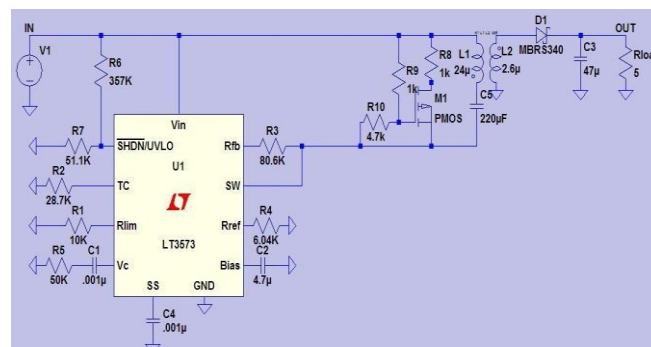

Fig. 1: Implemented Improved Flyback converter

## 3. OPERATING PRINCIPLE

During the primary switch ON state, the primary windings voltage is positive and lower than input, due to the series capacitor (CS) voltage drops. As in a conventional Flyback converter this positive voltage switches the output diode (DO) off, causing the load energy to be entirely supplied by the output capacitor. Due to the primary windings positive voltage, the magnetizing current builds up and flows in the series capacitor, charging it. Thus, in this period, both the transformer and the series capacitor are storing energy. During the primary mosfet OFF state the auxiliary switch is ON; the capacitor voltage then appears across primary windings, reversing the transformer polarity. The output rectifier can thus conduct, providing an energy path from the transformer to the load, as in the conventional Flyback. Due to the reverse transformer polarity, the magnetizing current starts to decrease, thus indicating the transfer to the secondary side of the previously stored transformer energy. If the magnetizing current falls to zero, it is able to become negative, by starting to flow in the auxiliary mosfet; the discontinuous conduction mode of operation, which exists in the conventional Flyback converter, is thus eliminated. Further, in order to be the charge in the series capacitor correctly balanced, a negative discharging current has to flow in the series capacitor via the auxiliary mosfet and the primary windings. Thus, in this period even the series capacitor supplies to the secondary side the energy taken from the input during the ON time.

## 4. STEADY STATE ANALYSIS

For the steady-state analysis purpose we assume ideal switches and diodes, and a constant voltage on CS. By balancing the flux in the magnetizing inductance, the mean voltage across the series capacitor is derived:

$$V_{CS} = D \cdot V_{IN} \quad (1)$$

The voltage across the transformer during the two converter states (referred to the primary switch), are thus given by:

$$V_{P,(OFF)} = -V_{CS} = -V_{IN} \cdot D \quad (2)$$

$$V_{P,(ON)} = V_{IN} - V_{CS} = V_{IN} \cdot (1 - D) \quad (3)$$

By the means of transformer and diode D O, the primary windings off voltage (2) is reflected to the output, The improved converter transfer function is thereby:

$$V_o/V_{in} = D/n \quad (4)$$

In order to calculate the average current flowing in the secondary side during the primary switch OFF period, we balance the charge in the output capacitor:

$$I_o \cdot D = (I_{S,OFF} - I_o) \cdot (1 - D) \quad (5)$$

The OFF period averaged secondary current ( $I_{S,OFF}$ ) is thus given by:

$$I_{S,OFF} = I_o / (1-D) \quad (6)$$

Further, in order to calculate the magnetizing current mean value, we apply the charge balance law to the series capacitor:

$$I_m \cdot D = ((I_{S,OFF} / n) - I_m) \cdot (1 - D) \quad (7)$$

Where  $I_m$  is the mean magnetizing current. By substituting (6) for  $I_{S,OFF}$  in (7), we obtain:

$$I_m = I_o / n = P_o / V_{IN} \cdot D \quad (8)$$

Where we also used (4) to obtain the last term on the right. The magnetizing current ripple is given by:

$$\Delta I_{Lm} = V_{IN} \cdot (1-D)D \cdot T_s / L_m \quad (9)$$

Where  $T_s$  is the switching period.

The output diode off voltage can be calculated as:

$$V_{D,OFF} = (V_{P,(ON)} / n) + V_o = V_o / D \quad (10) \text{ where}$$

(3) and (4) have been used.

## 5. COMPARISON WITH THE CONVENTIONAL FLYBACK

A tight comparison is carried out below to demonstrate the benefits introduced by the improved topology over the conventional Flyback converter. In order to provide a valid comparison, we assume two converters with the same electrical specifications, i.e. the same input voltage, the same output voltage and output power. Each paragraph shows and demonstrates a single benefit introduced by the discussed topology.

### I. REDUCED MOSFET VOLTAGE STRESS

In the conventional Flyback converter the mosfet off voltage is given by:

$$V_{OFF} = V_{IN} / (1-D) \quad (11)$$

This value is greater than input voltage and it diverges when duty cycle approaches unity. On the other hand, for the improved converter both the switch off voltages are reduced and clamped to  $V_{IN}$ , thus allowing to select two mosfets with breakdown voltage ratings very close to the input voltage, and to supply more power to the load. Further, the lowered and clamped mosfet voltage allows the improved converter to extend the duty-cycle. The benefits introduced employing an higher duty-cycle are explained in the following II, III, IV paragraphs.

### II. REDUCED OUTPUT RECTIFIER VOLTAGE STRESS

For the conventional Flyback the output diode off voltage is given by:

$$V_{D,OFF} (CONV) = (V_{P,(ON)} / n) + V_o = V_o / D \quad (12)$$

Where  $V_{P,(ON)}$  is equal to the input voltage, and where we have used the conventional Flyback output to input transfer function [1]. Eq. (12) is the same as (10) for the improved Flyback. Thus, for the same output voltage, the extended duty cycle allows the improved converter to reduce the output diode voltage stress.

### III. SMALLER MAGNETIZING INDUCTANCE AND AC LOSSES

For the basic Flyback the magnetizing ripple current can be calculated as:

$$\Delta I_{Lm} = V_{IN} \cdot D \cdot T_s / L_m \quad (13)$$

By comparing (13) with (9), it is seen that for the same input voltage and switching frequency, by employing an higher duty-cycle, the magnetizing current ripple for the improved converter is lowered, thus allowing a small magnetizing inductance value to be selected, and smaller AC losses to be present in the core.

#### IV. REDUCED TRANSFORMER CORE SIZE

Since the improved and conventional Flyback secondary circuits are identical, the secondary averaged current (6) is the same for both converters. However, in the conventional Flyback this current is supplied entirely by the magnetizing inductance. The averaged magnetizing current (referred to primary side) for the conventional Flyback is thus given by:

$$I_{m,conv} = I_s / n = I_o / (1-D).n = P_o / V_{IN} . D \quad (14)$$

Where we used the conventional Flyback output to input transfer function, to calculate the last term. Eq. (14) is equal to (8), obtained for the improved converter. However, by employing an higher duty-cycle value, the improved converter shows a lower transformer bias current, so allowing to reduce the transformer core and gap sizes. Further, the thinner core gap allows the leakage flux to be reduced, speeding up the input to output energy transfer process and increasing the efficiency.

#### V. DCM OPERATION ELIMINATED

As previously seen, during the OFF period the auxiliary switch allows the magnetizing current to invert its direction, as a difference from the conventional Flyback. Thus, the discontinuous conduction mode (DCM) does no longer exists for the improved converter, allowing to eliminate the minimum value constrain for the magnetizing inductance, necessary in the conventional Flyback to avoid the DCM operation.

#### VI. REDUCED TRANSFORMER ENERGY REQUIREMENTS

For the conventional Flyback the mean power transferred to the secondary side by the transformer during the OFF period is given by:

$$\begin{aligned} P_{m,conv} &= I_m . V_{P,OFF} = (P_o / V_{IN}.D) . (V_{IN} . (D/1-D)) \\ &= P_o + P_o . D/1-D = P_o + P_{CO} \end{aligned} \quad (15)$$

Where, is the mean power absorbed by the output capacitor during the OFF period to replace the charge supplied to the load during the ON time, so calculated:

$$P_{CO} = (I_{S,OFF} - I_o).(V_o) = P_o . D/1-D \quad (16)$$

Where  $I_{S,OFF}$  is given by (6). Thereby, from (15), as expected for the conventional Flyback, the transformer supplies both the load power ( $P_o$ ) and the output capacitor power ( $P_{CO}$ ). On the other hand, for the improved converter, the power supplied by the transformer during the OFF period is given by:

$$P_{m,prop} = I_m . V_{P,OFF} = (P_o/V_{IN}.D).(V_{IN}.D) = P_o \quad (17)$$

Thus, in the improved converter the transformer has just to supply the energy to the load, so allow reducing the transformer energy requirements. On the other hand, the energy to the output capacitor is supplied by the introduced series capacitor. As a demonstration we write:

$$\begin{aligned} P_{CS} &= (I_s/n - I_m).(V_{IN}.D) = (I_s/n - D).(V_{IN}.D) \\ &= P_o . D/1-D = P_{CO} \end{aligned} \quad (18)$$

According to (16).

#### 6. ZERO VOLTAGE TRANSITIONS

The auxiliary switch makes it possible to achieve soft switching transitions for both mosfet. To understand this issue we look at the dead times preceding each mosfet turning on. When primary switch is turned off the current in the transformer is positive. This current cannot interrupt abruptly, because a primary leakage inductance is present.

Thus, it starts to flow into the primary mosfet output capacitor, charging it. When the primary mosfet voltage reaches the input voltage value, the body diode of the auxiliary switch starts to conduct, carrying the leakage inductance energy. The auxiliary switch voltage is thus clamped to zero and it can be switched on at zero

voltage. When the primary switch is turned off the current in the transformer is negative. In fact, during the OFF period the current is supplied to the secondary side by the magnetizing inductance and the series capacitor, thus generating an inverted current. This current cannot interrupt abruptly, because a primary leakage inductance is present. Thus, it starts to flow into the auxiliary mosfet output capacitor, charging it. When the auxiliary mosfet voltage reaches the input voltage value, the body diode of the primary switch starts to conduct carrying the leakage inductance energy. The primary switch voltage is thus clamped to zero and it can be switched on at zero voltage.

## 7. SIMULATION RESULTS

For 24V input and 5V 1A output, the conventional Flyback and the improved converter have been simulated and compared to verify the theoretical analysis. The component and parameter values employed are given in tab.I.

Table 7.1 Simulated Converters Specifications

Parameters	Improved Flyback	Conventional Flyback
Specifications		
Duty cycle	90%	45%
Turn ratio	8 : 1	7.5 : 1
Primary and secondary leakage inductance	100nH	
Primary inductance	10 $\mu$ H	470 $\mu$ H
Series capacitor	10 $\mu$ F	Not present
Mosfet output capacitance	200pF	

The simulator involved is LTspice XVII, supplied by Linear Technologies. The conventional Flyback is operated in DCM. All the simulation results showed are for the full load condition.

Fig.7.1 shows the primary mosfet voltage of the improved and the conventional Flyback. The OFF voltage, due to the improved topology, is reduced and clamped to the input. Note that for the improved converter for a magnetizing inductance value about fifty times lower (see Tab 7.1), the current ripple is only ten times higher (see Fig.7.1), thus demonstrating the reduced ripple existing when the two converters employ the same magnetizing inductance value.

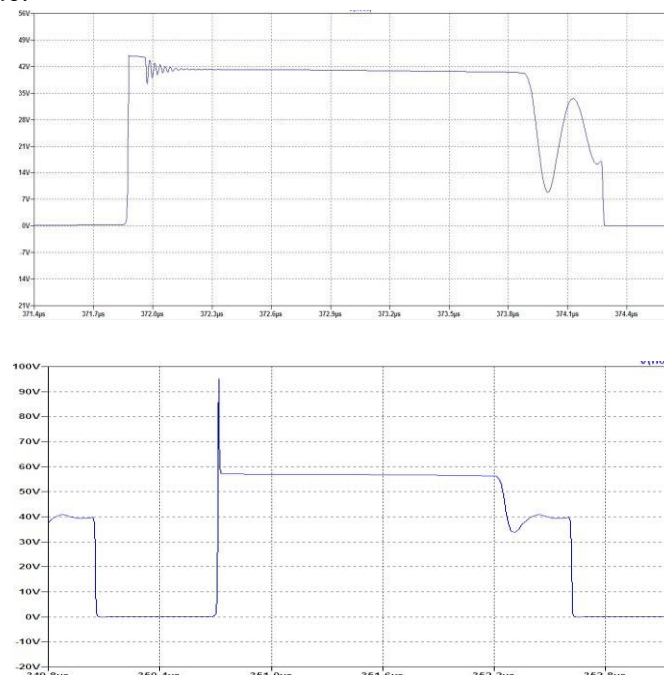

Figure 7.1: Primary mosfet voltage for the improved converter (top) and for the conventional Flyback (bottom).



Fig.7.2 shows the output voltage of the improved and the conventional Flyback. The OFF voltage, due to the improved topology, is reduced and clamped to the input.

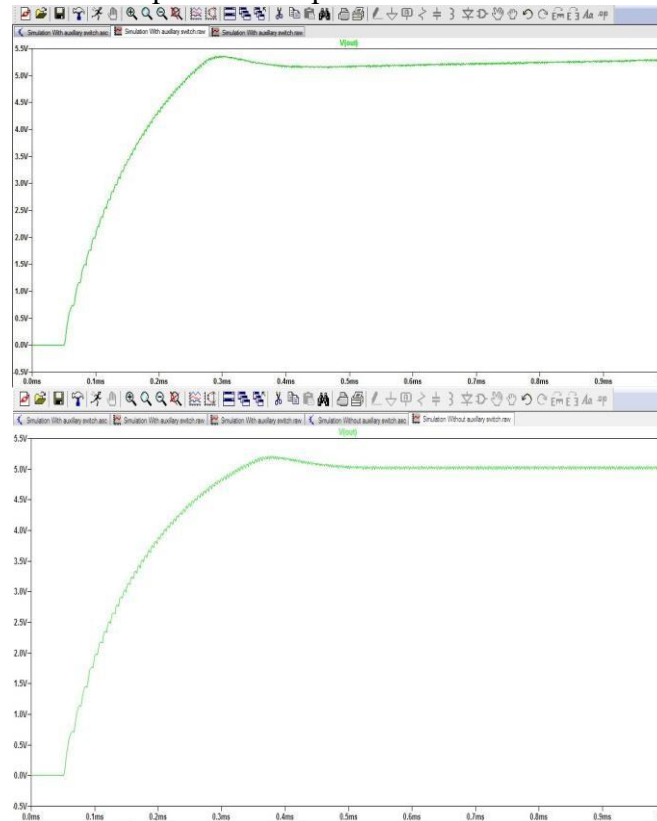

Figure 7.2: Output voltage for the improved converter (top) and for the conventional Flyback (bottom).

## 8. CONCLUSIONS

In this paper an higher efficiency smaller size Flyback converter, providing a reduced and clamped to VIN mosfet off voltage and the consequent capability to extend the duty cycle to unity, has been shown. As a consequence of the increased duty, the reduced output diode voltage stress, the lowered magnetizing current and transformer bias current have been proved. Due to the auxiliary switch, the DCM operation does no longer exist for the improved Flyback and moreover the series capacitor aids the transformer to supply the energy to the secondary side. Furthermore, ZVS transitions have been positively investigated for both mosfets. All these key features have been obtained maintaining the conventional Flyback simplicity, low parts counts and low cost. Thus, it can be concluded that the improved topology is a promising solution to increase the conventional Flyback output power and reduce its related size, making this converter particularly suitable for higher power density very low-cost applications

## REFERENCES

- I. C. Pesce and J. Riedemann, "A DC-DC Converter Based On Modified Flyback Converter Topology" *IEEE LATIN AMERICA TRANSACTIONS*, vol. 14, no. 9, pp. 3949-3956 SEPTEMBER 2016.
- II. Farnaz Ghodousipour, Navid Golbon and Gerry Moschopoulos "A DC-DC Converter with Dual Flyback Converter Topology" *IEEE 978-1-4673-4355-8/13 pp. 1999-2014* , 2013.

- III. Jeong Sang Yoo, Taeyoung Ahn, Gyeongbu Yu, Jongmin Lee, and Jaehak Lee, “A Study on Novel Active Clamp Snubber Applied DC-DC Quasi Resonant Flyback Converter to Effectively Reduce Switch Voltage Surge” *IEEE 78-1-5386-3246-8/17*, 2017.
- IV. Ju-Suk Kang, Young-Ho Kim, Sun-Jae Youn, Chung-Yuen Won and Yong-Chae Jung “Active Clamp Flyback Inverter Considering Leakage Inductance of Transformer for Photovoltaic AC Modules” *IEEE Vehicle Power and Propulsion Conference, Oct. 9-12,2012, Seoul, Korea, pp. 13791383, October 2012.*
- V. G. M. Ponzio, G. Capponi, P. Scalia and V. Boscaino, “An Improved Flyback Converter” *IEEE 978-14244-3388-9/09*, 2009.
- VI. K. Soltanzadeh, M. Dehghani and R. Riahi, “Dual-passive snubber dual-switch forward converter” *IEEE ELECTRONICS LETTERS*, Vol. 53 No. 15 pp. 1064–1066, 20th July 2017.
- VII. Ashraf A. Mohammed and Samah M. Nafie, “Flyback Converter Design for Low Power Application” *IEEE International Conference on Computing, Control, Networking, Electronics and Embedded Systems Engineering, 2015, 978-1-4673-7869-7/15, pp. 447-450, 2015.*
- VIII. Sung-Sae Lee, Seong-Wook Choi, and Gun-Woo Moon, Member, IEEE, “High Efficiency ActiveClamp Forward Converter With Transient Current Build-Up (TCB) ZVS Technique” *IEEE TRANSACTIONS ON INDUSTRIAL ELECTRONICS, VOL. 54, NO. 1, 0278-0046, pp. 310-318. February 2007.*
- IX. Hyeon-Seok Lee, Hyung-Jin Choe, Seok-Hyeong Ham, and Bongkoo Kang, Member, IEEE, “High-Efficiency Asymmetric Forward-Flyback Converter for Wide Output Power Range” *IEEE Transactions on Power Electronics, DOI 10.1109/TPEL.2016.,0885-8993, 2015.*