

Comparative Analysis of Vibration Suppression Techniques in Active Suspension Systems

Ethan Welles, Ava Moreno

Massachusetts Institute of Technology, Cambridge, USA

Abstract—In this paper, vibration control response of passenger seat in quarter car model having three degrees of freedom is studied. Three different control strategies are taken into account using Adaptive Neuro Fuzzy Inference System (ANFIS) controller. In first case, ANFIS controller is applied in main suspension of active quarter car model. In second case, passenger seat suspension is assembled with ANFIS controller. Finally, both main and passenger seat suspensions are integrated with ANFIS controller. Simulation work under random road excitations is performed using passive and controlled quarter car models for performance comparison of passenger ride comfort. Ride comfort analysis is also compared as per ISO 2631-1 criterion. The obtained simulation responses are compared taking passenger seat acceleration and displacement response in time and frequency domain for the selection of best control strategy in designed quarter car model.

Keywords—Active suspension system, ANFIS controller, passenger ride comfort, quarter car model.

I. INTRODUCTION

VEHICLE ride comfort is dependent on the effectiveness of suspension system in minimizing the vertical vibrations transmitted from road surface to vehicle body. The overall vehicle performance in terms of ride comfort and road holding ability is controlled by the type of assembled suspension system such as passive, semi-active or active type [1], [2]. The road induced vibration suppression capabilities of traditional passive and semi-active suspension systems is limited and shows controlling in a certain frequency range only. Thus desired working results related to passenger and vehicle structure safety cannot be achieved during running period on various speeds and road profiles. Active suspension system can provide desired vehicle performance over a large frequency range and can adjust the supplied damping force instantly by actuators depending on the intensity of vibrations sensed by the assembled sensors. Active and semi-active controller based technology has been also used in vehicle suspension system and seat suspension [3]-[8].

In past, various developed linear and non-linear control algorithms have been used in vehicle active suspension systems and they provide varying results in vibration suppression. Fialho and Balas [9] selected the adaptation factor where a combination of nonlinear backstepping and linear parameter-varying technique were used in active quarter car model. Huang and Lin [10] used a neural network based sliding mode controller. Lauwerys et al. [11] applied μ -

approximation based adaptive sliding mode controller for vibration control of active quarter car system. Salem and Aly [13] studied the effectiveness of Fuzzy and PID control using simulation work in active quarter car model. Shirjoposht et al. [14] proposed an optimal law and used Extended Kalman Filter for states estimation in an active quarter car model. Sun et al. [15] developed finite-frequency method based on the Kalman–Yakubovich–Popov lemma. Heidari and Homaei [16] used back propagation neural network technique for designing PID controller. Rosli et al. [17] used Active Force Control with Iterative Learning as well as a PID controller for practical implementation in active quarter car model. Emam [18] designed PID controller based on the fuzzy self-tuning mechanism for an active quarter car suspension system. Devdutt and Aggarwal [19] compared the passenger ride comfort issues in active quarter car model with a hybrid fuzzy – PID controller with coupled rules. Park [20] compared the performance of three fuzzy sliding mode controllers with each other in active suspension system having different boundary layers and sign function. Devdutt [21] used self tuning fuzzy controller in active quarter car suspension system having three degrees of freedom.

The main objective of this paper is to compare the passenger ride comfort taking passive and active quarter car models with three degrees of freedom. The ANFIS controller is designed for integration in active quarter car models. The designed controller is assembled in main suspension system, passenger seat suspension system as well as in both main and passenger seat suspension system. Simulation work is performed for performance comparison of passenger ride comfort under random road excitation in time and frequency domain respectively.

II. ACTIVE QUARTER CAR MODEL

Here, a quarter car active suspension model with 3 degrees of freedom is designed for evaluating the dynamic performance. It is assumed that the tyre remains in direct contact with the road surface. The assembled spring, damper and the actuators constitute the parts of an active suspension as shown in Fig. 1. In this model, the roll and pitch motions of the vehicle are ignored while the vertical motions of passenger seat, sprung mass and unsprung mass are selected for analysis purpose.

synthesis based controller in quarter car test-rig of active suspension. Huang and Chen [12] developed a functional

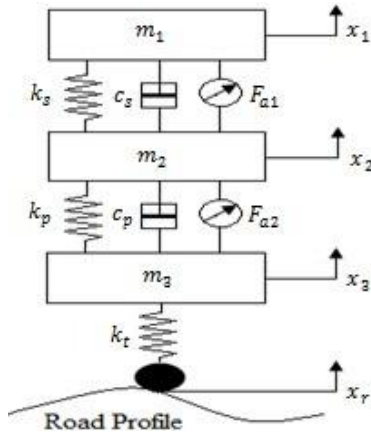

Fig. 1 Active quarter car model

For fully controlled quarter car model:

$$0 \quad (1)$$

$$(2)$$

$$(3)$$

where m_1 and m_2 are the mass of passenger seat, sprung mass and unprung mass respectively, c_s and c_p are damper damping coefficients of passenger seat suspension and main suspension while k_s and k_p are spring stiffness of passenger seat suspension and main suspension respectively. F_{a1} and F_{a2} are supplied control force in passenger seat suspension and main suspension respectively. Here, x_1 , x_2 and x_3 are the displacements of the considered masses in quarter car model and x_r represents the road excitation.

III. ANFIS CONTROLLER DESIGN

ANFIS controller contains the advantage of fuzzy controller as well as neural network. Neural networks are highly successful in dealing with mathematical data whereas fuzzy logic shows computational effectiveness in incorporating human expertise related to the control system being modeled. Thus ANFIS controller in combination with neural network and fuzzy controller show enhanced capability by adopting learning ability based on mathematical data. The structure and fuzzy if-then rules of FIS in ANFIS controller is automatically built depending on the selected MFs shapes and input output pairs based on the neural network learning algorithm. The integration of ANFIS controller in designed active quarter car model with two inputs and one output is shown in Fig. 2. The ANFIS controller architecture for the same is shown in Fig. 3. It is a two input one output model. Here, a circle presents a fixed node while a square

presents an adaptive node whose parameters are updated continuously during the training or adaptation process.

Each of the two crisp inputs e and de to the ANFIS controller has been represented by five linguistic terms with the total combinations of $5 \times 5 = 25$ rules. As per first-order Sugeno inference system, the output generated by each rule can be written as:

where, $i = 1, 2, 3, \dots, 25$. The two inputs e and de are related to the linguistic labels A_i and B_i while u_i is the output from the ANFIS controller, $\{f_1, \dots, f_{25}\}$ are the consequent parameters.

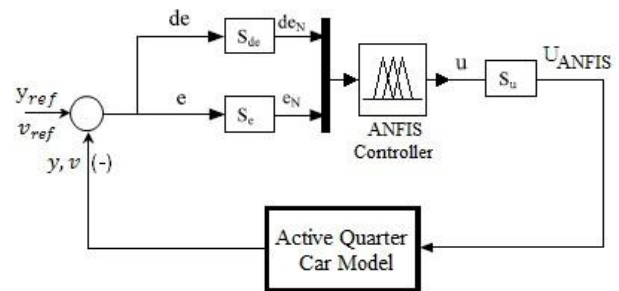

Fig. 2 ANFIS controller in active quarter car model

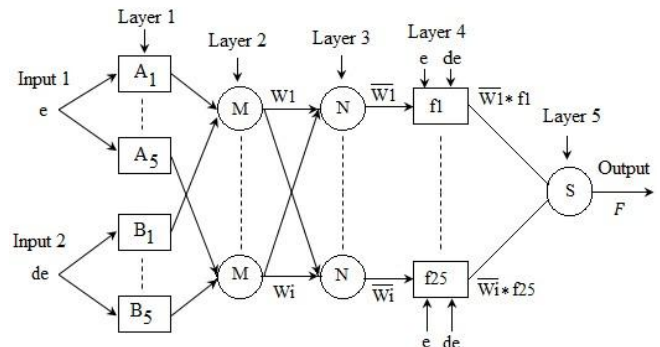

Fig. 3 Five layer ANFIS structure for active quarter car model

The detailed function of each layer of designed five layer ANFIS controller is discussed here. Layer 1 receives the defined two inputs to perform fuzzification function having each node as the adaptive node with a square shape. Here, five selected triangular fuzzy MFs are implemented for each input. Each node shows the degree of membership of the inputs with matching portions and the calculation work of the corresponding membership values is done in this layer. Layer 2 is also known as rule layer. Each node in layer 2 is a fixed node (non adaptive) with a circular shape and labeled M. It contains 25 nodes and performs the work of a simple multiplier for fuzzy inference. Each node calculates the firing strength of each fuzzy rule. This layer provides the output through cross multiplication of all the input signals. Layer 3 is the normalization layer with 25 fixed nodes with a circular shape and labeled N. Here, the normalized firing strength of each node is calculated as the ratio of the firing strength of the rule to the total of all rules firing strength. Layer 4 is also known as defuzzification layer. Each node in this layer

is an adaptive node with a square shape and connected to the corresponding normalization node of layer 3. Each node in this layer also receives the two inputs and . The output from each node in this layer is equal to the product of the output from each node of layer 3 (normalized firing strength) and a first order polynomial which are the functions of the two input signals. Layer 5 is a single fixed node and labeled S. This node computes the summation of all incoming signals from layer 4 and generates the overall output of the ANFIS controller.

The mathematical data set selected for training was 170 rows having input and output values. The number of epoch was fixed

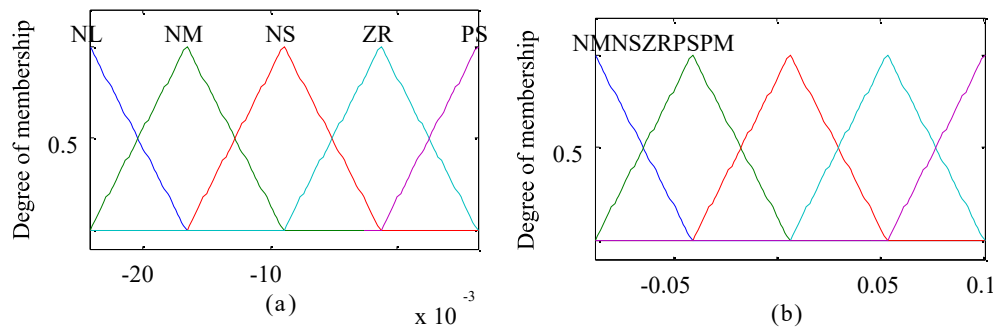

Fig. 4 Membership functions for (a) error signal (), (b) derivative of error signal ()

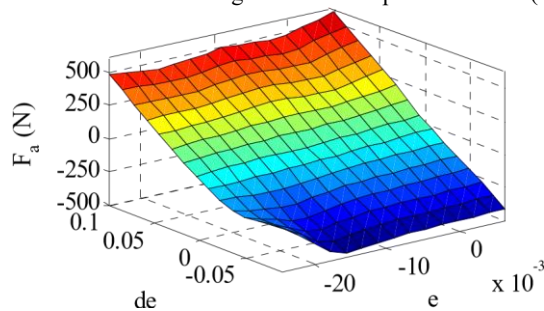

Fig. 5 Input/ output ANFIS surface plot

IV. SIMULATION WORK AND RESULTS

For vibration analysis work, passive and active quarter car Simulink models with ANFIS controller were developed in MATLAB-Simulink environment taking mathematical equations. The vehicle speed was fixed as 40 km/hr and simulation time as 4 seconds to obtain the passenger seat vibration response in terms of acceleration and displacement values. The random road profile used for running vehicle excitation is shown in Fig. 6.

The values of the selected parameters in quarter car model are as: $m_s = 75 \text{ kg}$, $m_{us} = 325 \text{ kg}$, $c_s = 40 \text{ kg/s}$, $k_{us} = 850 \text{ N/m}$, $k_s = 1550 \text{ N/m}$, $k_{us} = 7550 \text{ N/m}$, $c_{us} = 20 \text{ 000 N/m}$ and $c_s = 180 \text{ 000 N/m}$ respectively.

A. Simulations for Random Road Profile

Simulation results of passenger seat acceleration and displacement in passive and active quarter car models are shown in Fig. 7. It can be observed that fully suspension controlled (FSC) active quarter car model with ANFIS controller provide best response in vibration reduction of passenger seat compared to passive, main suspension controlled (MSC) and passenger seat

as 50 for training purpose. The number of selected triangular shape membership functions was 5 each for the selected two input variables and as shown in Fig. 4. This resulted into formation of 25 ($5 \times 5 = 25$) number of rules. The inputs and are represented by five linguistic terms, such as NL: Negative Large, NM: Negative Medium, NS: Negative Small, ZR: Zero, PS: Positive Small and PM: Positive Medium respectively. Fig. 5 shows the surface plot of the designed ANFIS controller with two inputs and one output respectively.

suspension controlled (PSSC) cases. The mathematical results of graphical response are presented in Table I. It can be seen that fully controlled suspension system provide much improved response in terms of passenger seat acceleration and displacement values out of the various considered strategies.

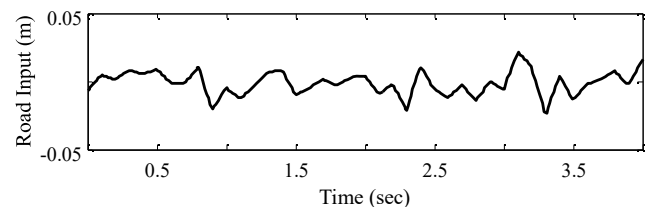

Fig. 6 Random road profile

TABLE I
SIMULATION RESULTS UNDER RANDOM ROAD PROFILE

Controller Type	Acceleration (m/s^2)		Displacement (m)	
	Peak	RMS	Peak	RMS
Passive	1.4130	0.6566	0.0187	0.0090
PSSC	0.7341	0.2669	0.0054	0.0040
Improvement (%)	48.05	59.35	71.12	55.56
MSC	0.6088	0.2600	0.0031	0.0028
Improvement (%)	56.91	60.40	83.42	68.89
FSC	0.4333	0.1333	0.0015	0.0023
Improvement (%)	69.33	79.70	91.98	74.44

B. Spectral Density Analysis

The power spectral density results of passenger seat were calculated using time domain response of the selected various quarter car models. The spectral densities of passenger seat acceleration and displacement response are shown in Fig. 8. It

can be seen that fully controlled active quarter car model with ANFIS controller achieved best performance in frequency domain compared to passive and other controlled strategies.

damping force compared to passenger seat suspension observed that fully controlled suspension with ANFIS controller in main as

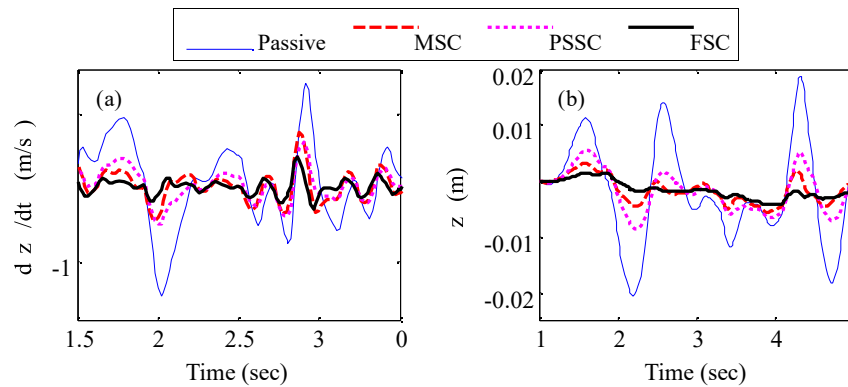

Fig. 7 Passenger seat response (a) acceleration (b) displacement

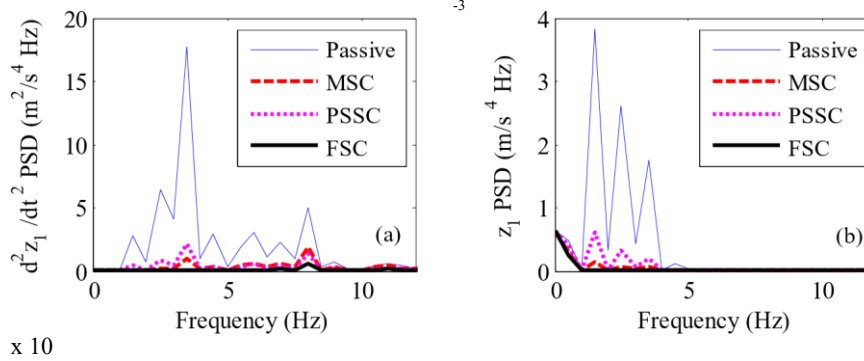

Fig. 8 PSD response of passenger seat under random road profile (a) acceleration (b) displacement

C. Controllers Response

The damping force supplied by ANFIS controller as well power consumed in various suspension alternatives is shown in Figs. 9-12. It can be seen from Figs. 9 and 10 that ANFIS controller in main suspension system provides high values of controlled system.

Figs. 10 and 11 show damping force supplied by ANFIS controller in case of fully suspension controlled active quarter car model in main and passenger seat suspension respectively. The assembled controllers performance in terms of four different criterion such as integral of square error (ISE), integral of time multiplied absolute error (ITAE), integral of absolute error (IAE) and integral of time multiplied square error (ITSE) respectively are tabulated in Table II. It can be

well as in passenger seat suspension system provide best performance on IAE, ITAE, ISE and ITSE criteria.

TABLE II
CONTROLLER RESPONSE UNDER RANDOM ROAD PROFILE

Controllers	Performance			
	IAE	ITAE	ISE	ITSE
Passive	0.0373	5.89E-04	0.0847	1.21E-03
PSSC	0.0269	3.02E-04	0.0599	6.11E-04
Improvement (%)	27.88	48.73	29.28	49.50
MSC	0.0244	2.49E-04	0.0530	4.87E-04
Improvement (%)	34.58	57.72	37.43	59.75
FSC	0.0242	2.44E-04	0.0521	4.67E-04
Improvement (%)	35.12	58.57	38.49	61.40

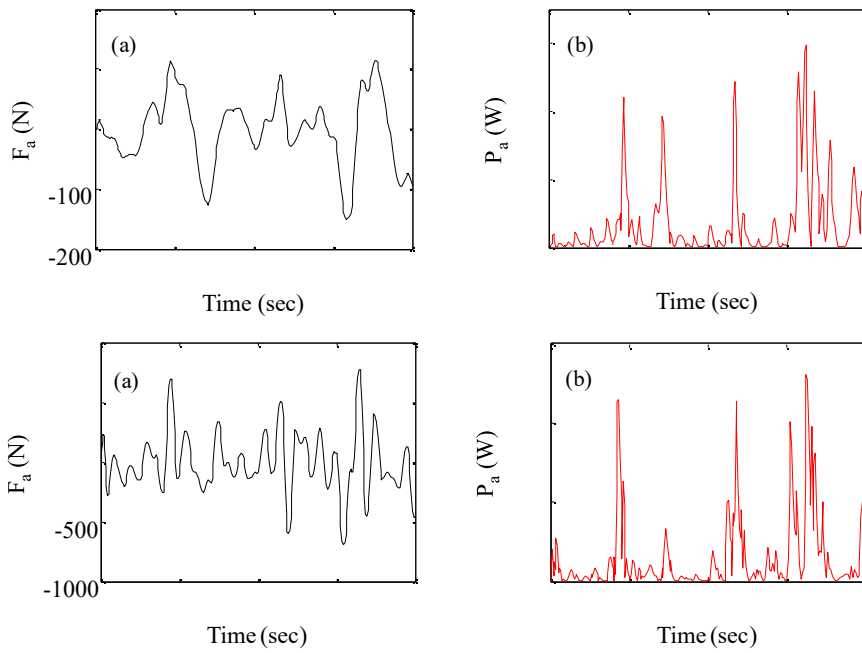

Fig. 9 Main suspension controlled (a) Damping force supplied by ANFIS controller (b) Power consumed by ANFIS controller
Fig. 10 Passenger seat suspension controlled (a) Damping force supplied by ANFIS controller (b) Power consumed by ANFIS controller

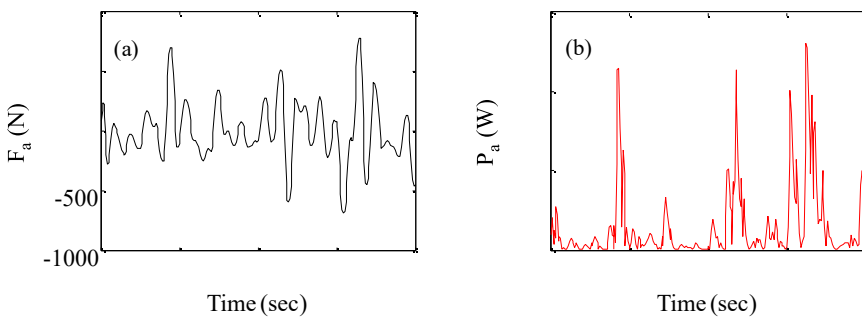

Fig. 11 Fully suspension controlled (a) Damping force supplied by ANFIS controller in main suspension (b) Power consumed by ANFIS controller in main suspension

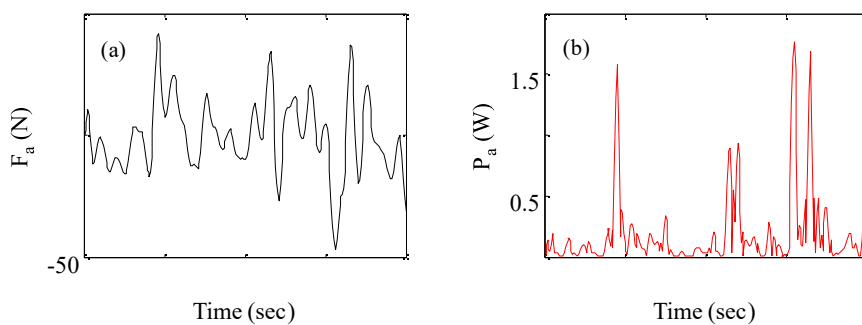

Fig. 12 Fully suspension controlled (a) Damping force supplied by ANFIS controller in passenger seat suspension (b) Power consumed by ANFIS controller in passenger seat suspension



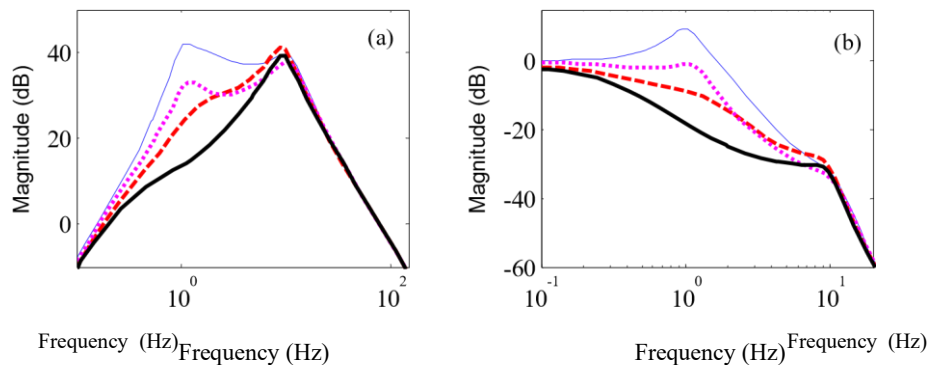

Fig. 13 Bode plot (a) Passenger seat acceleration (b) Passenger seat displacement

V. FREQUENCY RESPONSE ANALYSIS

The graphical response in frequency domain of passenger passive quarter car model for passenger seat, sprung mass and unsprung mass respectively. Frequency response analysis provides valuable information regarding response of the system at the resonance frequency values. All controlled suspension systems with ANFIS controller provide superior response in reduction in amplitude of frequency near passenger seat resonance values i.e. 0.9321 Hz. But the response provided by fully controlled suspension system is best compared to other designed quarter car models in frequency domain.

VI. RIDE COMFORT EVALUATION AS PER ISO 2631-1

Travelling passengers in vehicles are subjected to vibration exposure generating ride discomfort, injury to body parts as well as health risks depending on the intensity and duration of transmitted vibrations to human body. Thus, passenger whole body vibration is calculated taking frequency weighted acceleration magnitude as per international standard recommended in ISO2631-1 [22]. It also helps the vehicle manufacturers in following and meeting the set national and international automotive standards and guidelines which are necessary for developing safe vehicles. In this study, the criterion selected for ride comfort evaluation taking road induced generated vibration signals into account are frequency Weighted RMS acceleration (WRMS), Maximum Transient Vibration Value (MTVV) and Vibration Dose Value (VDV) respectively. It can be seen from Table III that calculated values WRMS, MTVV and VDV of fully controlled active suspension system with ANFIS controller are much lower compared to passive

Fig. 13. The 3 resonance frequency values for the designed

suspension system and other controlled strategies showing the effectiveness of proposed controller in providing better ride comfort and safety of passengers.

TABLE III
COMPARISON AS PER ISO 2631-1 STANDARD

Controller Type	Criterion		
	WRMS	MTVV	VDV
Passive	0.4414	1.0572	3.4242
PSSC	0.2272	0.7861	1.7985
Improvement (%)	48.53	25.64	47.48
MSC	0.1958	0.5562	1.4137
Improvement (%)	55.64	47.39	58.71
FSC	0.1255	0.4533	0.9614
Improvement (%)	71.57	57.12	71.92

VII. CONCLUSIONS

The present paper was related to the comparative analysis of passenger ride comfort in quarter car model with three degrees of freedom. The designed ANFIS controller was applied in main and passenger seat suspensions respectively. The simulation results in graphical and mathematical results showed the effectiveness of fully controlled suspension system under random road excitations compared to other cases. In conclusion, fully controlled suspension system with ANFIS controller can be used in vehicles for getting high ride comfort and safety of travelling passengers.

REFERENCES

- [1] Ahmadian M and Pare C “A quarter-car experimental analysis of alternative semi active control methods”, *J. Intell. Mater. Syst. Struct.*, Vol. 11, No. 8, 2000, pp. 604–612.
- [2] Devdutt and Aggarwal, M L, “Fuzzy control of passenger ride performance using MR shock absorber suspension in quarter car model”, *International Journal of Dynamics and Control*, Vol. 3, No. 4, 2015, pp. 463-469.
- [3] Devdutt and Aggarwal, M L “Active Vibration Control of Passenger Seat with HFPIDCR Controlled Suspension Alternatives”, *World Academy of Science, Engineering and Technology*, Vol. 10, No. 5, 2016, pp. 916-23.
- [4] Devdutt and Aggarwal, M L. “Hybrid Fuzzy-PID Control of a SemiActive Quarter Car System, MR *International Journal of Engineering and Technology*, Vol. 6, No. 2, 2014, pp. 21-26.
- [5] Devdutt and Aggarwal, M L “Comparative Analysis of Passenger Ride Comfort Using Various Semiactive Suspension Alternatives”, *International Journal of Recent advances in Mechanical Engineering*, Vol.3, No. 3, 2014, pp. 79-89.
- [6] Devdutt and Aggarwal, M L “Passenger seat vibration control of a semiactive quarter car system with hybrid Fuzzy – PID approach”, *International Journal of Dynamics and Control*, Vol. 5, No. 2, 2017, pp. 287-296.
- [7] Wu J D and Chen R J “Application of an active controller for reducing small-amplitude vertical vibration in a vehicle seat”, *Journal of Sound and Vibration*, Vol. 274, No. 3–5, 2004, pp. 939–951.
- [8] Maciejewski I “Control system design of active seat suspensions”, *Journal of Sound and Vibration*, Vol. 331, No. 6, 2012, pp.1291–1309.
- [9] Fialho I, Balas G J “Road adaptive active suspension design using linear parameter-varying gain-scheduling”, *IEEE Transactions on Control System Technology*, Vol. 10, No. 1, 2003, pp. 43–54.
- [10] Huang S J, Lin W C “A neural network sliding controller for active vehicle suspension”, *Materials Science Forum*, Vol. 440-441, 2003, pp. 119-126.
- [11] Lauwerys C, Swevers J, Sas P “Robust linear control of an active suspension on a quarter car test-rig”, *Control Engineering Practice*, Vol. 13, No. 5, 2005, pp. 577-586.
- [12] Huang, S J and Chen, H Y “Adaptive sliding controller with self-tuning fuzzy compensation for vehicle suspension control”, *Mechatronics*, Vol. 16, 2006, pp. 607–22.
- [13] Salem, M MM and Aly, AA “Fuzzy control of a quarter-car suspension system”, *World Academy of Science, Engineering and Technology*, Vol. 3, No. 5, 2009, pp. 224-229.
- [14] Shirjoposht, N P, Hassanzadeh, I, Hashemzadeh, F and Alizadeh, G “Optimal active suspension control based on a quarter-car model: an analytical solution”, *International Journal of Vehicle Safety (IJVS)*, Vol. 5, No. 1, 2010, pp. 1-20.
- [15] Sun, W, Gao, H and Kaynak, O “Finite frequency H_∞ control for vehicle active suspension systems”, *IEEE Trans. Control Syst. Technol*, Vol. 19, 2011, pp. 416–22.
- [16] Heidari M and Homaei H, “Design a PID Controller for Suspension System by Back Propagation Neural Network”, *Hindawi Publishing Corporation Journal of Engineering*, Volume 2013, Article ID 421543, 9 pages.
- [17] Rosli R, Mailah M, and Priyandoko G “Active Suspension System for Passenger Vehicle using Active Force Control with Iterative Learning Algorithm”, *WSEAS Trans. Syst. Control*, Vol. 9, 2014, pp. 120-129.
- [18] Emam A S “Fuzzy Self Tuning of PID controller for active suspension system”, *Advances in Powertrains and Automotives*, Vol. 1, No. 1, 2015, pp. 34-41.
- [19] Devdutt and Aggarwal M L “Active Vibration Control of Passenger Seat with HFPIDCR Controlled Suspension Alternatives”, *World Academy of Science, Engineering and Technology*, Vol. 10, No. 5, 2016, pp. 91623.
- [20] Park S and Rahmdel S “A new fuzzy sliding mode controller with autoadjustable saturation boundary layers implemented on vehicle suspension”, *International Journal of Engineering-Transactions C: Aspects*, Vol. 26, No. 12, 2013, pp. 1401-1410.
- [21] Devdutt “Self-Tuning Fuzzy Control of Seat Vibrations of Active Quarter Car Model”, *World Academy of Science, Engineering and Technology*, Vol. 11, No. 5, 2017, pp. 1053-1059.
- [22] ISO: 2631-1, Mechanical vibration and shock – evaluation of human exposure to whole – body vibration; 1997.