

# Impact Dynamics of Composite Materials

Amira H. Al-Khateeb, Riad F. Al-Ghamdi

King Fahd University of Petroleum and Minerals, Dhahran, Saudi Arabia

**Abstract**—Carbon fiber reinforced polymers are widely used to strengthen steel structural elements. These structural elements are normally subjected to static, dynamic and fatigue loadings during their life-time. CFRP laminate is commonly used to strengthen these structures under the subjected loads. A number of studies have focused on the characteristics of CFRP sheets bonded to steel members under static, dynamic and fatigue loadings. However, there is a gap in understanding the bonding behavior between CFRP laminates and steel members under impact loading. This paper shows the effect of high load rates on this bond. CFRP laminate CFK 150/2000 was used to strengthen steel joints using Araldite 420 epoxy. The results show that applying a high load rate significantly affects the bond strength but has little influence on the effective bond length.

**Keywords**—Adhesively-bonded joints, Bond strength, CFRP laminate, Impact tensile loading.

## I. INTRODUCTION

STRENGTHENING of steel structures using carbon fiber reinforced polymers (CFRPs) has been widely undertaken in recent years. CFRP is an excellent method for strengthening deteriorated structures compared to conventional methods [1], [2]. The bond between CFRP and steel members is the major parameter. A number of studies have examined the effect of the bond between CFRP (sheet and laminates) and steel joints under static loadings [3]-[5]. The effect of fatigue loading on CFRP sheets has also been studied [6], [7]. As deteriorated steel members are usually subjected to impact loading, they need to be strengthened using CFRP laminates. The effect of impact loading on CFRP sheet-steel joints has been studied to find the ultimate joint strength and the effective bond length[8]. However, there is a lack of understanding of the effect of impact loading on the bond between CFRP laminate and steel members. This paper studies the effect of impact loading on adhesively-bonded CFRP-steel double-strap joints. The results focus on the maximum bond strength, effective bond length and failure modes. The dynamic results are then compared with static results to find the enhancement percentage.

## II. MATERIAL PROPERTIES

In order to prepare the adhesively-bonded double-strap specimens, low modulus CFRP was used to strengthen the steel joints using Araldite 420 epoxy. The tensile strength and modulus of elasticity of the CFRP and Araldite 420 were 2900MPa, 165GPa and 32MPa, 1.9GPa respectively.

## III. PROCEDURE OF SPECIMEN PREPARATION

A total of 54 CFRP-steel double-strap specimens were prepared in this program to find the effect of static and dynamic loading on the joint properties. The dimensions of the steel plates were 200mm long, 16mm thick and 40mm wide, the CFRP dimensions were different bond lengths, 1.4mm thick and 20mm wide. The same preparation procedure was followed for both static and dynamic samples. Each specimen was prepared by bonding two steel plates together using Araldite 420 epoxy; the surface of the jointed steel plates was sandblasted to remove oil, paint and grease along the bond length. The surface was then cleaned with acetone to remove all remaining dust and to ensure good chemical bonding. The adhesive layer was then applied along the required length and CFRP laminate was attached on one side of the joint. After the epoxy set (about 24 hours), the same procedure was followed for the other side of the specimen. Care was taken to attach the CFRP on the centerline of the specimen to avoid any eccentricity in loading. The specimens were cured for 7-10 days to obtain the maximum capacity of the epoxy, as recommended by the manufacturer's technical sheet. A schematic view of a specimen is shown in Fig. 1.

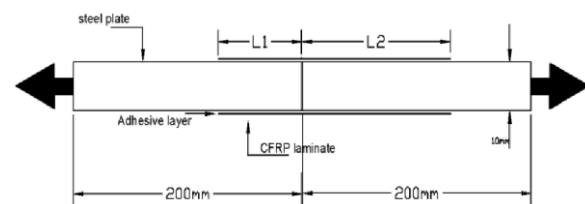

Fig. 1 Schematic view of the CFRP-steel double-strap specimen

## IV. EXPERIMENTAL SET-UP AND TEST PROCEDURE

The main parameters used in this test program were the bond length and the load rates. As shown in Fig. 1, there were two lengths; L1 varied from 30mm to 130mm for the static tests and from 40 to 100mm for the dynamic tests, whereas L2 was constant and longer than L1 for all specimens, to ensure that failure occurred in the shorter side. For the quasi-static specimens, an MTS 250kN machine was used at Swinburne University of Technology. The specimens were set up for

displacement control and the machine monitored the resisting load, and the load rate for the quasi-static specimens was 2mm/min. For the dynamic specimens, a fabricated tensile impact rig was used. This impact rig was fabricated for tensile impact tests at Monash University in 2011[9]. A schematic view of the fabricated rig is shown in Fig. 2.

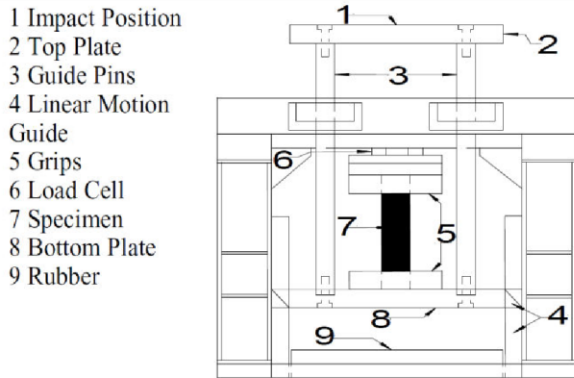

Fig. 2 Schematic view of the fabricated tensile impact rig [8]

The high velocity was generated by dropping a mass of 300Kg from a height of 0.575m on this rig. The velocity was then calculated as follows:

$$v = \sqrt{2gh}$$

where:  $v$ : is the velocity in (m/sec);  $g$ : is the gravity ( $m/sec^2$ );  $h$ : is the height of dropping mass (m). Therefore, for the height of 0.575m the generated velocity is 3.35 m/sec.

### V. TEST RESULTS

Two load rates were adopted in this test program: 2mm/min represents the static loading and 3.35m/sec represents the impact loading. The results showed a significant increase in load-carrying capacity between these two load rates.

#### A. Static Test Results

A total of 33 CFRP-steel double-strap joints were tested under quasi static load. The experimental static results for the double-strap joint specimens are summarized in Table I.

As shown in Table I, three specimens were tested for each length. The average load is the mean of three loads. From the table the maximum bond strength, effective bond length and failure mode can be discussed in detail as follows:

#### 1. Maximum Failure Load

It is obvious that the higher bond length gives a higher joint capacity up to a certain bond length. The joint capacity appears to be constant at bond length of 110mm and beyond, which means that 110mm is the effective bond length. Fig. 3 shows the relation between maximum load capacity in kN and bond length in mm.

TABLE I  
TEST RESULTS OF DOUBLE-STRAP JOINTS UNDER STATIC TENSILE LOAD

Specimen label	$L_1$	$L_2$	Max Load capacity (kN)			Failure mode
			$P_1$	$P_2$	Average Load (kN)	
S30	30	100	41	40.9	41.0	De-bonding
			41.1	49.2		
			49.2	50.5		
S40	40	100	52.5	50.5	50.7	De-bonding
			50.5	52.2		
			52.2	59		
S50	50	100	58.8	57.6	60.0	De-bonding
			59	57.6		
			57.6	70.5		
S60	60	100	70.5	59.1	69.1	De-bonding
			59.1	75		
			75	36.4		
S70	70	110	77.8	70	76.5	De-bonding
			70	36.4		
			36.4	37.4		
S80	80	120	37.4	36.7	36.8	De-bonding
			36.7	36.8		
			36.8	30.6		
S90	90	130	30.6	33.5	33.5	De-bonding
			33.5	105		
			105	96		
S100	100	140	96	100	100.3	De-bonding
			100	106		
			106	99.9		
S110	110	150	99.9	108	108.0	De-bonding
			108	07.1		
			07.1	112		
S120	120	160	112	107	108.7	De-bonding
			107	08.5		
			08.5	09.3		
S130	130	170	09.3	09.5	09.5	De-bonding
			09.5	109.1		
			109.1	09.5		

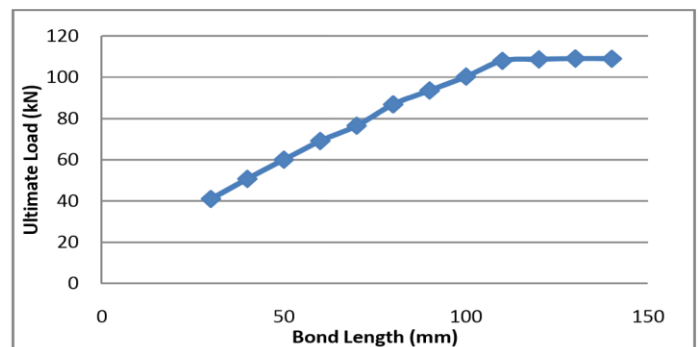

Fig. 3 Load vs. bond length for the quasi-static specimens

#### 2. Failure mode

complete de-bonding between steel and adhesive layer for all bond lengths, as shown in Figs. 5 (a) and (b).

In 2007 Zhao and Zhang summarized six possible failure modes for adhesively-bonded joints between steel and FRP [10]. The six failure modes are shown in Fig. 4. They can be defined as follows: (a) steel and cohesive layer interface failure, (b) cohesive layer failure, (c) FRP and adhesive debonding failure, (d) FRP delamination, (e) FRP rupture and (f) steel yielding failure.

In the current tests, the failure mode is shown to be

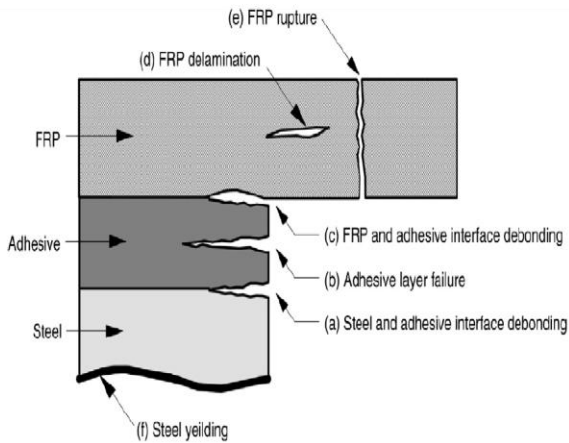

Fig. 4 The possible failure modes in adhesively-bonded joints[10]

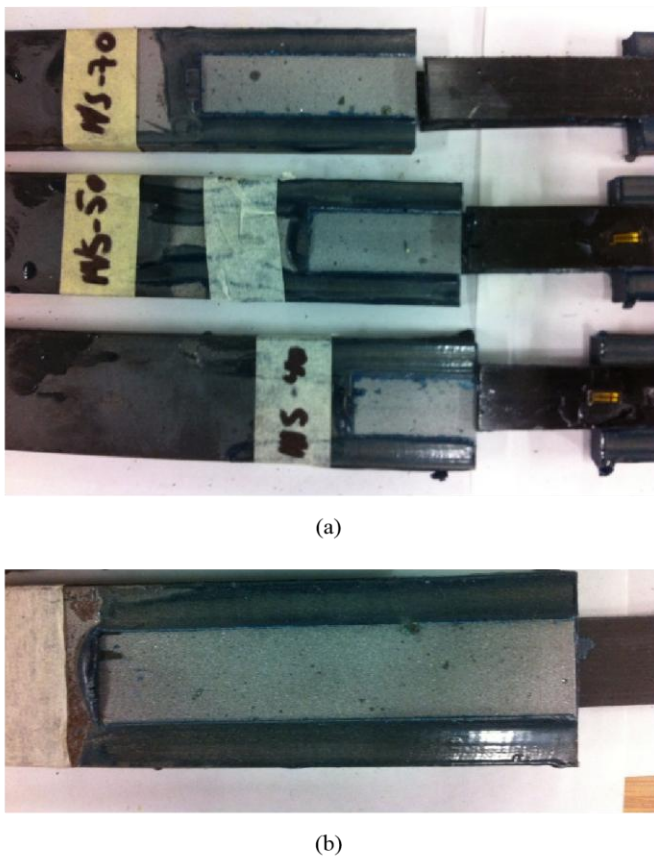

Fig. 5 De-bonding failure for the quasi-static specimens: (A) less than the effective bond length, (B) beyond the effective bond length

**B. Dynamic Test Results**

A total of 21 CFRP-steel double-strap joints were tested under impact load; the load rate as 3.35m/sec. The experimental results of the dynamic test are summarized in Table II.

The results focus on the maximum capacity of the double-strap joints with different bond lengths; each bond length was tested three times and the average loads are shown.

TABLE II  
TEST RESULTS OF DOUBLE-STRAP JOINTS UNDER DYNAMIC TENSILE LOAD

Specimen label	L <sub>1</sub>	L <sub>2</sub>	Max Load capacity (kN)		Failure mode
			P <sub>1</sub> P <sub>2</sub> P <sub>3</sub>	Average Load (kN)	
S40	40	100	82.4	76.6	De-bonding+ adhesive failure
			72.1		
			75.4		
S50	50	100	100	100.3	De-bonding+ adhesive failure
			02.7		
			98.3		
S60	60	100	09.5	106.6	De-bonding+ adhesive failure
			04.7		
			05.8		
S70	70	110	10.1	113.9	De-bonding+ adhesive failure
			15.9		
			15.7		
S80	80	120	122	120.3	De-bonding+ adhesive failure+ FRP delamination
			21.8		
			17.2		
S90	90	130	29.2	131.1	De-bonding+ adhesive failure+ FRP delamination
			30.5		
			132		
S100	100	140	31.9	130.3	De-bonding+ adhesive failure+ FRP delamination
			31.7		
			29.0		

The results can be summarized as follows:

**1. Maximum Failure Load**

A significant increase is shown in the high-speed tests; the load capacity increased by 50% compared with the static test for the short bond lengths, whereas this percentage became less as the bond length increased and reached close to the effective bond length. This significant increase can be attributed to the fact that the shear capacity of the adhesive shows a significant increase under high strain rates [11]-[13]. Fig. 6 shows the effect of impact load on joint capacity against the bond length for the impact test. The effect of impact loading on the effective bond length is also shown in Fig. 6. The effective bond length for static loading is 110mm, while it is 90mm for dynamic loading. This increase in the joint capacity of CFRP laminate-steel members has a good agreement with the same joint but using CFRP sheet, reported in 2011[8].

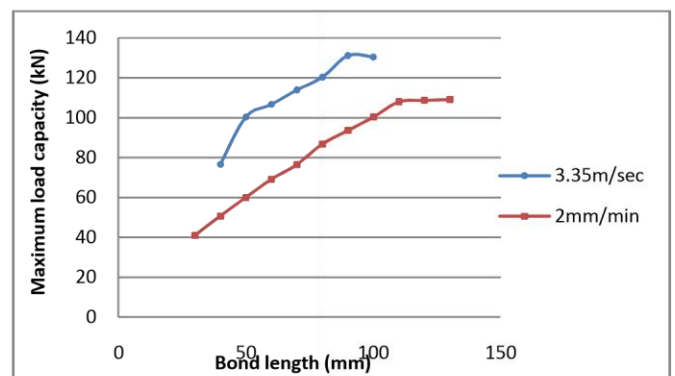

Fig. 6 Ultimate joint capacity vs. bond length for the two load rates

**2. Failure Mode**

Depending on the possible failure modes explained above

and shown in Fig. 4, the failure modes for the dynamic specimens were mixed between (a) adhesive-steel de-bonding and (b) adhesive layer failure for the specimens with bond lengths of less than the effective bond length. However, for specimens with bond lengths close to and beyond the effective bond length, the failure mode was mixed among (a) adhesivesteel de-bonding, (b) adhesive layer failure and (d) FRP delamination. This can be explained by the epoxy shear strength increase with the high load rates. Figs. 7 (a) and (b) show the failure mode of the dynamic specimens.



(a)



(b)

Fig. 7 Failure modes for the dynamic specimens: (a) De-bonding + adhesive failure, (b) De-bonding + adhesive failure + FRP delamination

## VI. CONCLUSION

This paper has investigated the effect of high load rate on the bond between CFRP laminate and steel plate. The results showed a significant increase in the load-carrying capacity compared to that in static loading. The ratio of dynamic maximum capacity to

the static maximum capacity for each length studied was higher for the short lengths and became less as the bond length increased. The dynamic specimens were 50% higher than the static specimens in terms of the maximum capacity of the joint. The failure mode was also different in the case of dynamic loading, due to the increase in adhesive shear strength. Impact loading had little effect on the effective bond length.

## REFERENCES

- [1] L. C. Hollaway and P. R. Head, "The future for the advanced polymer composite in the civil infrastructure," Chapter 9 in *Advanced Polymer Composites and Polymers in the Civil Infrastructure*, Oxford: Elsevier Science, 2001, pp. 287-292.
- [2] S. Xia and J. Teng, "Behaviour of FRP-to-steel bonded joints," in *Proceedings of the international symposium on bond behaviour of FRP in structures*, 2005, pp. 419-26.
- [3] S. Fawzia, X. L. Zhao, R. Al-Mahaidi, and S. Rizkalla, "Bond characteristics between cfrp and steel plates in double strap joints," *Advanced Steel Construction*, vol. 1, pp. 17-27, 2005.
- [4] C. Wu, X. Zhao, W. Hui Duan, and R. Al-Mahaidi, "Bond characteristics between ultra high modulus CFRP laminates and steel," *Thin-Walled Structures*, vol. 51, pp. 147-157, 2, 2012.
- [5] Y. Yu, S. Chiew, and C. Lee, "Bond failure of steel beams strengthened with FRP laminates—Part 2: Verification," *Composites Part B: Engineering*, vol. 42, pp. 1122-1134, 2011.
- [6] Y. J. Kim and K. A. Harries, "Fatigue behavior of damaged steel beams repaired with CFRP strips," *Engineering Structures*, vol. 33, pp. 1491-1502, 2011.
- [7] M. Bocciarelli, P. Colombi, G. Fava, and C. Poggi, "Fatigue performance of tensile steel members strengthened with CFRP plates," *Composite Structures*, vol. 87, pp. 334-343, 2, 2009.
- [8] H. A. Al-Zubaidy, X. L. Zhao, and R. Al-Mahaidi, "Effect of Impact Tensile Load on Strength of CFRP Bonded Steel Plate Joints," *Procedia Engineering*, vol. 14, pp. 1312-1317, 2011.
- [9] H. A.-A. B. Al-Zubaidy, "Behaviour of bond between CFRP sheet and steel under impact tensile loading," ed.
- [10] X.-L. Zhao and L. Zhang, "State-of-the-art review on FRP strengthened steel structures," *Engineering Structures*, vol. 29, pp. 1808-1823, 2007.
- [11] H. Al-Zubaidy, X.-L. Zhao, and R. Al-Mihaidi, "Mechanical Behaviour of Normal Modulus Carbon Fibre Reinforced Polymer (CFRP) and Epoxy under Impact Tensile Loads," *Procedia Engineering*, vol. 10, pp. 2453-2458, 2011.
- [12] T. Yokoyama and H. Shimizu, "Evaluation of impact shear strength of adhesive joints with the split Hopkinson bar," *JSME International Journal. Series A, Solid Mechanics and Material Engineering*, vol. 41, pp. 503-509, 1998.
- [13] S. L. Raykhere, P. Kumar, R. Singh, and V. Parameswaran, "Dynamic shear strength of adhesive joints made of metallic and composite adherents," *Materials & Design*, vol. 31, pp. 2102-2109, 2010.