

# Advancements in STATCOM Performance with Energy Storage

Amir Hossein Khodadadi, Yara F. Al-Mansoori

*Department of Electrical Engineering, University of Calgary, Canada*

**Abstract**—The use of Flexible AC Transmission System (FACTS) devices in a power system can potentially overcome limitations of the present mechanically controlled transmission system. Also, the advance of technology makes possible to include new energy storage devices in the electrical power system. The integration of Superconducting Magnetic Energy Storage (SMES) into Static Synchronous Compensator (STATCOM) can lead to increase their flexibility in improvement of power system dynamic behaviour by exchanging both active and reactive powers with power grids. This paper describes structure and behaviour of SMES, specifications and performance principles of the STATCOM/SMES compensator. Moreover, the benefits and effectiveness of integrated SMES with STATCOM in power systems is presented. Also, the performance of the STATCOM/SMES compensator is evaluated using an IEEE 3-bus system through the dynamic simulation by PSCAD/EMTDC software.

**Keywords**—STATCOM/SMES compensator, chopper, converter, energy storage system, power systems.

## I. INTRODUCTION

In recent years the progress in semiconductor technologies have led to the commercial availability of devices capable of very high power handling, leading to the concept of FACTS. Based on power electronics converter FACTS devices are capable of rapid regulation of various network quantities [1]. Among them, STATCOM can be employed to power quality improvement, power oscillations damping, transient and dynamic stability improvement [2]-[4], therefore providing reactive power support and regulating power flows in the network. A STATCOM can only absorb/inject reactive power and consequently is limited in the degree of freedom. By the addition of energy storage, STATCOM would have the ability to independently and simultaneously exchange both real and reactive power with a transmission system, enabling a STATCOM to perform several functions. Whereas the problems of uneven active power flow, transient and dynamic stability, sub-synchronous oscillations, and power quality issues can be impacted more effectively by active power control [5] this integration can be significantly. Among the different technologies for energy storage, SMES for power utility applications have received considerable attention due to their characteristics, such as rapid response, high power and high efficiency [6] and provides a number of benefits to

utilities: diurnal load leveling, damping slow power oscillations, spinning reserve and transient stability enhancement. However, in this paper integrated of SMES into STATCOM compensator. Adding SMES enhances the performance of a STATCOM and

possible reduces the MVA rating requirements of the STATCOM operating alone.

Specifically, this paper will:

- Present specifications and performance principles of the SMES and STATCOM/SMES compensator.
- Present benefits and enhances flexibility of integration of SMES into STATCOM.
- Compare the performance of proposed STATCOM/SMES compensator with alone STATCOM.

## II. OPERATION AND SPECIFICATION OF SMES

A SMES unit is a device that stores energy in the magnetic field generated by the dc current flowing through a superconducting coil [7]. A SMES system consists of a superconducting coil, the cryogenic system, and the power conversion or conditioning system (PCS) with control and protection functions [8]. Its total efficiency can be very high since it does not require energy conversion from one form to the other. Because of its benefits and unique characteristics, the SMES device is quite competitive with other energy storage technologies. Although SMES was initially considered as a diurnal energy storage device, other potential applications can be: dynamic and transient stability, frequency support, transmission capacity improvement, power quality enhancement.

## III. THE CONNECTION OF SMES TO AC POWER SYSTEM

As it can be seen from Fig. 1 a power conditioning system (PCS) connects the SMES unit to an ac power system and is used to charge/discharge the coil [8], [9]. A transformer provides the connection to the power system and reduces the operating voltage to acceptable levels for the PCS. Two types of power conversion system are commonly used. One option uses a Current Source Inverter (CSI) to both interface to the ac system and charge/discharge the coil. The second option uses a Voltage Source Inverter (VSI) to interface to the ac system and dc-dc chopper to charge/discharge the coil.

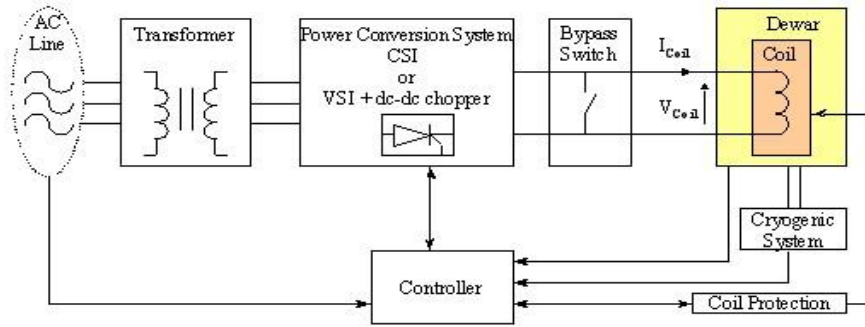

Fig. 1 The structure of SMES system

A. The Current Source Converter (CSC)

Due to its large inductance, the SMES coil acts like a current source. Therefore, it may also be directly connected to an ac system via a CSC as illustrated in Fig. 2. With a CSC, the energy management for the SMES coil is incorporated into the ac side current output control. CSCs are simpler to control because they are not feedback coupled through the ac side impedances.

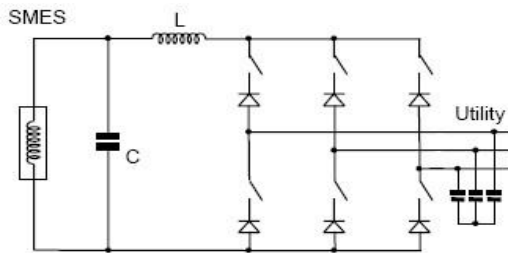

Fig. 2 The CSC topology

B. The Voltage Source Converter (VSC)

Fig. 3 shows in detail the chopper VSC topology. It used a two-quadrant chopper and a VSC linked with a dc voltage. The chopper changes the dc current from the SMES coil to dc voltage, and a VSC changes the dc voltage into a three-phase ac current [9], [10]. In all applications where fast power delivery and absorption are needed to increase ac system stability, the dc-dc chopper must be bi-directional. Control of the real and reactive powers were accomplished by controlling firing angles of the GTOs and the dc voltage that is determined by the duty ratio of the chopper.

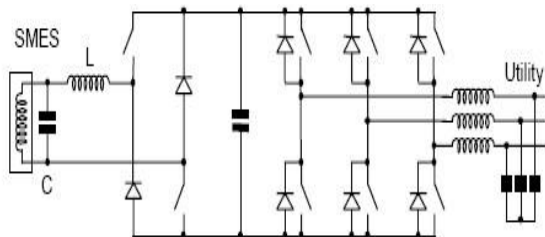

Fig. 3 The chopper - VSC topology

TABLE I

COMPARISON BETWEEN VOLTAGE AND CURRENT SOURCE CONVERTERS

Issue	VSC	CSC
Reactive power	Always full range available (no coil needed)	Minimum capacitive, but full range dependent on coil current
Capacitor Device	DC asymmetrical	AC Symmetrical (series diode)
AC system controls	complex	Easy, since decoupled
di/dt fault current	high	low
Implementation	easy	complex
Losses (inverter only)	lower	higher

Table I summarizes the differences between VSC and CSC.

IV. PROPOSED MODEL FOR THE STATCOM/SMES COMPENSATOR

A. General Concepts

In principle, STATCOM is a shunt connected device which injects reactive current into the ac system. Whereas the STATCOM can only absorb/inject reactive power, consequently is limited in the degree of freedom. The addition of SMES allows the STATCOM to inject and/or absorb active and reactive power simultaneously. A functional model of a STATCOM/SMES compensator is shown in Fig. 4. This model consists mainly of the STATCOM controller, the SMES coil and the dc-dc chopper is adopted as interface for two devices.

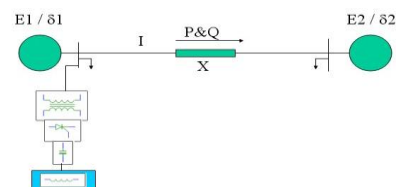

Fig. 4 General model of the proposed STATCOM/SMES compensator

*B. The Dc-Dc Chopper Operation in Order to Charge/Discharge SMES Coil*

There are three different modes of operation of the SMES coil. The first mode of operation is the charging of the SMES coil. The SMES coil charges relatively fast to its rated current. The second mode is the stand-by mode. In this mode the current in the SMES coil effectively circulates in a closed loop, which can also be called as a freewheeling mode. The third mode is the discharge mode, during which the SMES coil discharges into the dc-link capacitor. The three modes are shown in Fig. 5.

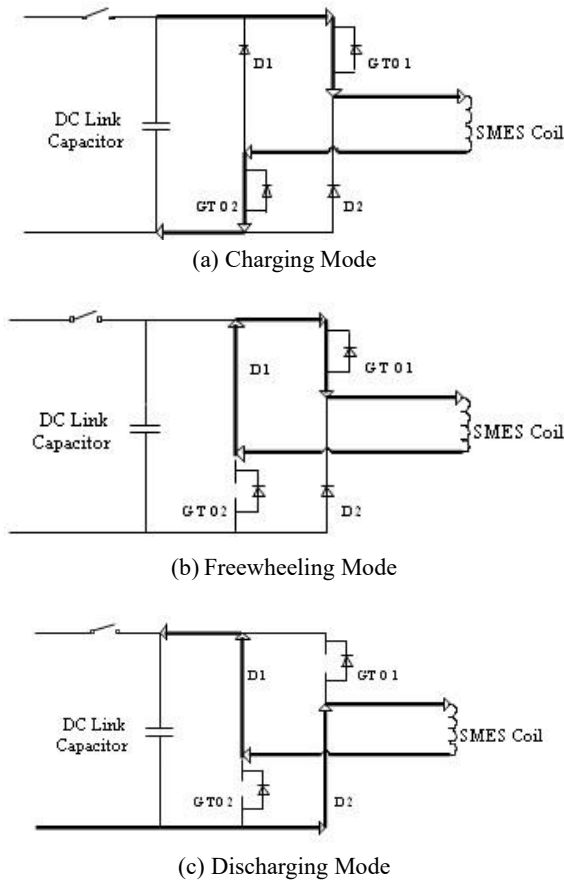

Fig. 5 (a), (b) and (c), Operating modes of SMES dc-dc chopper

**V. INCREASE THE BENEFIT OF EXISTING STATCOM BY ADDING WITH REAL POWER INJECTION**

The ability to rapidly damp oscillations, respond to sudden changes, dynamic and transient stability, power quality enhancement, correct load voltage profiles with rapid reactive power control and transmission capacity improvement are among the benefits of SMES system. The integration of SMES system into STATCOM can provide independent real and reactive power absorption/injection into/from the grid, leading to a more economical and/or flexible transmission control. The enhanced performance of a combined STATCOM/SMES compensator will have greater appeal to transmission service providers, as shown in Fig. 6.

The SMES can be added to a STATCOM to significantly improve the control actions of STATCOM. If a transmission line

experiences significant power transfer variations in a short time notice, a STATCOM/SMES compensator can be installed to relieve the loaded transmission line. The traditional STATCOM (without SMES) has only two possible steadystate operating modes: inductive (lagging) and capacitive (leading). Although both the STATCOM output voltage magnitude and phase angle can be controlled, they cannot be independently adjusted since the STATCOM has no active power capability. In the case of a STATCOM/SMES compensator, the number of operating modes is extended to four. These modes are namely, inductive with dc charge, inductive with dc discharge, capacitive with dc charge and capacitive with dc discharge, as shown in Fig. 7.

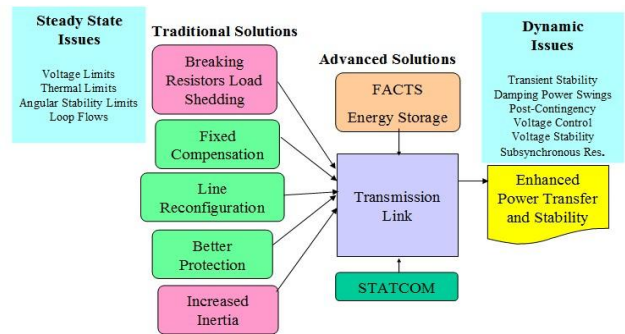

Fig. 6 Benefits of STATCOM with SMES

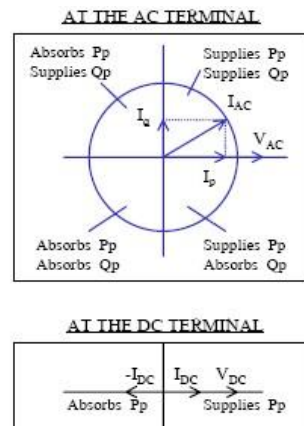

Fig. 7 STATCOM/SMES P-Q plane for each operating mode when it is connected to system in parallel

In Fig. 8 for the STATCOM, reactive power only operates in the vertical axis only. By addition of SMES, real power compensation can increase operating control of STATCOM. Therefore, by

using STATCOM/SMES compensator, real and reactive power can operate anywhere within PQ plane.

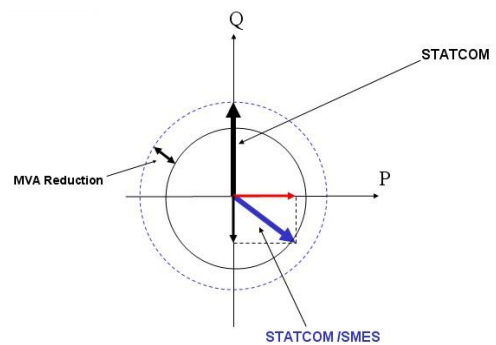

Fig. 8 Enhances functionality of STATCOM by addition of SMES

An advantage of using the STATCOM/SMES compensator for real power is that the STATCOM has a higher Q rating than P, and the SMES coil will affect only the P rating. P and Q sum orthogonally, so the effect on overall current of combining the SMES and STATCOM is less when both are used together, as shown in Fig. 8, than if both were used separately [8], [11]. The addition of real power transfer capability does not necessarily result in a large increase in the MVA rating of the converter, since the real power is in quadrature with the reactive power from the converter. The addition of real power capability may improve the performance of the converter enough that the total converter MVA rating could even be reduced.

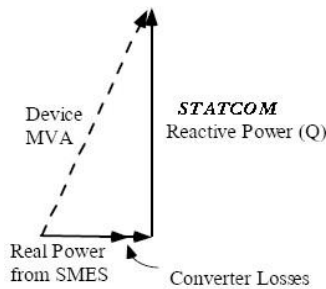

Fig. 9 Orthogonal Addition of SMES Real Power P and STATCOM Reactive Power Q

### VI. CONTROL SCHEME FOR THE STATCOM/SMES COMPENSATOR

The controller provides an active and reactive power command to achieve the desired system response. For optimal control of transmission capacity, it is desired to have a controller that can achieve independent active and reactive power responses [12]. To accomplish this goal, a proposed controller is developed that can produce the desired switching commands from independent active and reactive power commands. The control functions of the STATCOM/SMES compensator have two parallel independent parts for active power control and reactive power control. The active power control is to control the active power output of STATCOM/SMES compensator to suppress the generator rotor oscillation [13].

The reactive power control is to keep the terminal voltage at the reference value [13], [14]. Fig. 10 is the control blocks of the two parts. In Fig. 10 (a), the K in the first block is the multiplying factor. The second block is the resetting block which makes  $P_{out}$  zero when  $t \rightarrow \infty$ . The third block is a phase compensation block that will make  $P_{out}$  be synchronous with  $\Delta\omega$ . In Fig. 10 (b),  $K_{AVR}$ ,  $T_1$ ,  $T_2$ ,  $T_3$ , and  $T_4$  are the gain and time constants of the automatic voltage regulator. K is the negative feedback factor. In our case, there is no phase shift here with  $n=0$ .

### VII. RESULTS SIMULATION

The IEEE 3-bus system used to evaluate the dynamic performance of the proposed STATCOM/SMES compensator in form of a simplified single-line diagram is shown in Fig. 11. The base load used at bus 3 is a 750MW and 200Mvar load, and is modeled as a constant PQ. Each machine has a simple exciter,

and a simple governor is used for the machine at bus 1. The generators are modeled in detail by means of subtransient model.

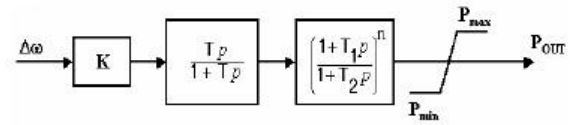

(a) Active power control function of STATCOM/SMES compensator

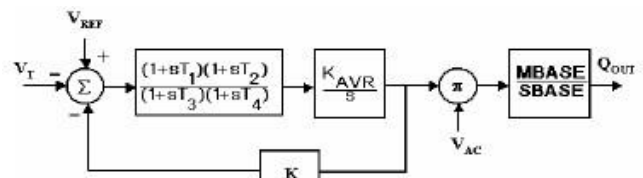

(b) Reactive power control function of STATCOM/SMES compensator

Fig. 10 Control function structure of STATCOM/SMES compensator

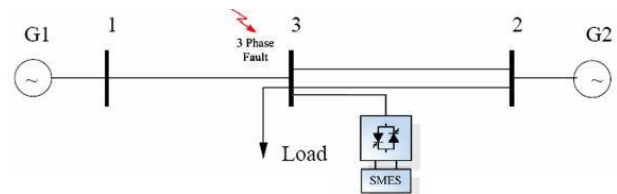

Fig. 11 IEEE 3-bus test system

In this case, a three-phase-to-ground fault at bus 3 is applied in the bulk power system (at  $t=0.1s$ ) and clearance of it. A 100Mvar STATCOM and a 200MJ/80MW were used in STATCOM/SMES compensator. The data for the STATCOM are given in Table II and used control scheme in [14]–[16] for STATCOM/SMES compensator.

TABLE II STATCOM DATA

$R_c (\Omega)$	$R_{trans} (\Omega)$	$X_{trans} (\Omega)$	$C (\mu f)$	$K_P$	$K_I$
0.64	0.54		0.121		

The simulation results were presented for operation on STATCOM/SMES compensator and alone STATCOM compensator in PSCAD/EMTDC software [17]. The specifications for active power variations, generator rotor angle variations and angular speed variations for generator connected to bus 1 are shown in Figs. 12, 13, and 14 respectively.

This results shows that STATCOM/SMES compensator is able to stabilize the system in a very short period and provide more damping in comparison with the case where the alone STATCOM was used.

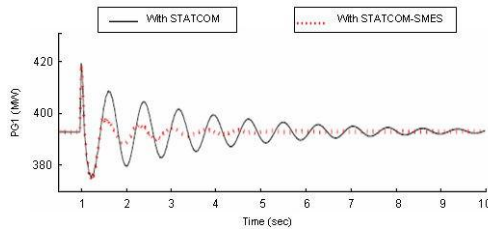

Fig. 12 Variation of generator active power

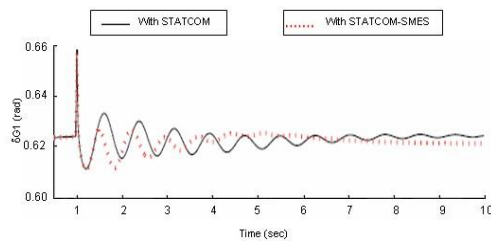

Fig. 13 Variation of rotor power angle

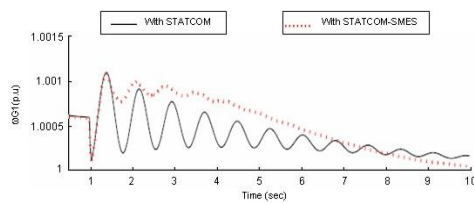

Fig. 14 Variation of angular speed

### VIII. CONCLUSION

This paper presents the specifications, operation of SMES system and STATCOM/SMES compensator. Also, benefits of integration of SMES system into STATCOM were presented. Combined STATCOM/SMES compensator would have the ability to independently and simultaneously, exchange both real and reactive power with a transmission system, enabling a single STATCOM to performance several functions. The simulation results show that STATCOM/SMES compensator has a more significant effect on the dynamic performance improvement compared to that alone STATCOM compensator.

### REFERENCES

- [1] N. G. Hingorani and L. Gyugyi, "Understanding FACTS Concepts and Technology of Flexible AC Transmission Systems", *IEEE Press*, 2000.
- [2] L. Gyugyi, "Dynamic compensation of ac transmission lines by solidstate synchronous voltage sources." *IEEE Trans. Power Delivery*, vol. 9, no. 2, pp. 904-911, April 1994.
- [3] L. Gyugyi, "Application Characteristics of Converter Based FACTS devices," *Power System Technology*, 2000. Proceedings. *Power Con 2000. International Conference*, vol.1, pp.391 - 396, 4-7 Dec. 2000.
- [4] P. Ribeiro, B. Johnson, M. L. Crow, A. Arsoy, and Y. Liu, "Energy storage systems for advanced power applications," *Proc. IEEE*, vol. 89, no. 12, pp. 1744–1756, Dec. 2001.
- [5] L. Zhang, C. Shen, Z. Yang, M. Crow, A. Arsoy, Y. Liu, S. Atcitty, "A comparison of the dynamic performance of FACTS with energy storage to a unified power flow controller," *IEEE Transactions on Power Deliver*, vol.6, pp.611-616, 2001.
- [6] V. Karasik, K. Dixon, C. Weber, B. Batchelder, G. Campbell, and P. Ribeiro, "SMES for power utility applications: a review of technical and cost considerations", *IEEE Trans on applied superconductivity*, vol.9, no.2, pp.541-546, June 1999.

- [7] R. Sedaghati, M. Hakimzadeh, M.H. Raouf, M. Mirzadeh, "Application of STATCOM-SMES Compensator for Power System Dynamic Performance Improvement," *International Journal of Electrical, Computer, Energetic, Electronic and Communication Engineering*, World Academy of Science, Engineering and Technology (WASET), vol. 8, no. 3, pp. 616-620, 2014.
- [8] R. Sedaghati, M. Hakimzadeh, A. Davodi, N. Javidtash, "Dynamic Modeling and Simulation of a STATCOM/SMES Compensator in Power Systems," *International Journal of Electrical, Computer, Energetic, Electronic and Communication Engineering*, World Academy of Science, Engineering and Technology (WASET), vol. 8, no. 5, pp. 798-801, 2014.
- [9] M.R. Shakarami, R. Sedaghati, M.B. Haddadi, "Analysis and Control of STATCOM/SMES Compensator in a Load Variation Conditions," *Advances in Electrical and Electronic Engineering (AEEE)*, vol. 12, no. 5, pp. 407-415, 2014.
- [10] R. Sedaghati, M. Hayatdavudi, M Eslami, "Analysis and Control of STATCOM/SMES Compensator in a Load Variation Conditions,"
- [11] R Sedaghati and H. Barati, "Improvement of Power System Dynamic Performance by Integration STATCOM/SMES," *The 2<sup>nd</sup> National Electrical Engineering Conference IAU, Najafabad Branch, Isfahan*, pp. 212-218, Feb 2010.
- [12] P. Ribeiro, B. Johnson, M. L. Crow, A. Arsoy, and Y. Liu, "Energy storage systems for advanced power applications," *Proc. IEEE*, vol. 89, no. 12, pp. 1744–1756, Dec. 2001.
- [13] H. Zhang, Y. Kang, P. Zhu, X. Kong, P. Liu, and J. Chen, "Theoretical analysis and experimental results on SMES in dynamic simulation test of power system," in *Proc. of IEEE Conf. Elect. Machines and Drives*, 2001, pp. 736-741.
- [14] Palo Alto, "Program on Technology Innovation: Modeling of SMES and Its Integration to the Power Grid," *EPRI Project Manager*, Oct 2005.
- [15] B.K. Johnson and H.L. Hess, "Incorporating SMES Coils into FACTS and Custom Power Devices," September 1998.
- [16] A. Arsoy, Y. Liu, S. Chen, Z. Yang, M.L. Crow, P.F. Ribeiro, "Dynamic Performance of a Static Synchronous Compensator with Energy Storage," *Tran. Power Systems*, vol.6, pp.605-610, 2001.
- [17] Manitoba HVDC Research Center, *PSCAD/EMTDC User's Manual*, 1988.