

Impact of Cutting Tool Geometry on Mechanical Properties of Friction Stir Welded Titanium Alloy 718

A. M. Kulkarni, R. S. Srinivas, S. B. Ramesh

Indian Institute of Technology, Mumbai, India

Abstract—A Friction stir welding tool is a critical component to the success of the process. The tool typically consists of a rotating round shoulder and a threaded cylindrical pin that heats the work piece, mostly by friction, and moves the softened alloy around it to form the joint. In this research work, an attempt has been made to investigate the relationship between FSW variables mainly tool profile, rotating speed, welding speed and the mechanical properties (tensile strength, yield strength, percentage elongation, and micro hardness) of friction stir welded aluminum alloy 5083 joints. From the experimental details, it can be assessed that the joint produced by using Triflute profile tool has contribute superior mechanical and structural properties as compared to Tapered unthreaded & Threaded tool for 1000rpm.

Keywords—Friction stir welding, Tool profile, Rotating speed, Strength, Speed ratio.

I. INTRODUCTION

FRICITION-STIR WELDING (FSW) is a solid state joining procedure, designed and demonstrated at The Welding Institute UK in December 1991 [1], that uses a third body tool to join two confronting surfaces. Heat is created between the tool and material which prompts a delicate district close to the FSW tool. It then mechanically intermixes the two pieces of metal at the joint's spot, and after that the softened metal (due to the elevated temperature) can be joined utilizing mechanical pressure. A non-consumable rotating tool with a specially designed pin and shoulder is inserted into the abutting edges of plates to be joined and traversed along the line of joint. The tool serves two primary functions: (a) heating of work piece, and (b) moving the material to produce the joint [2]. The heating is expert by friction between the tool and the work piece and plastic distortion of work piece. The confined heating softens the material around the pin and the combination of tool rotation and translation leads to movement of material from the front of the pin to the back of the pin [3]. Being a strong solid state joining procedure, friction stir welding offers various advantages like low distortion, absence of melt-related defects, high joint quality, and so forth when contrasted with other ordinary combination welding strategies [4].

With latest improvements in innovation of friction stir welding, it is currently conceivable to complete dissimilar welding of different sorts of steels with alloys of aluminum, magnesium, copper, titanium and other combinations [5].

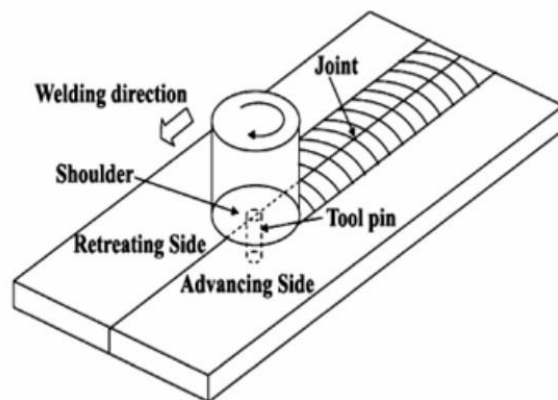


Fig. 1 Friction stir welding

The frictional heat generated by rotating the tool, stirring action of the pin plasticizes the material and the joint is produced by plastic deformation of the material. The pin turns as well as traverses along the weld's length, empowering to weld the two plates [6]. An investigation on effect of tool shape and welding parameters on the mechanical properties of a 5mm thick aluminum plates was done by [7]. Three shapes (triangle, square and round shapes) were utilized to weld the aluminum plates with diverse welding conditions. It has been found that increasing the rotational speed above 1000 rpm decreased the quality of joint notwithstanding have a poor welded surface. The hardness of the aluminum plates were observed to be higher when utilizing the triangle shape tool than other shapes. For a low rotation speed (560 rpm), the tool shape does not significantly influence the mechanical properties of the joints. Mechanical Properties and Temperature Distributions of Thin Friction Stir Welded Sheets of AA5083 were contemplated by [8]. Friction Stir welded (FSW), 0.8mm in thickness 5083 aluminum sheets have been considered. A special fixture, designed for ultra-thin sheets, and a simple cylindrical tool, was utilized. Mechanical properties demonstrate that yield stress off old specimens are below the base metal and by increasing in speed ratio (w/v) the average of micro hardness was diminished. Specimens were welded at speed ratio range of 18.58 to 34.84 have the best quality of tensile test and micro hardness. With speed rate decreasing microscopic defects may increase and with increasing of this rate up to 28.125 better mechanical properties achieved for Al 5083. The best welding results as far as mechanical and failure properties are in the 18.58 to 34.84 speed rate range. Experimental studies on friction stir welding of AA2011 and AA6063 aluminum combinations were researched by [9]. On assessment, it was found that welding quality (strength) enhances with increased tool rotation speed. Two distinctive tool pin geometries (square and hexagonal) and different process variables, i.e. rotational speeds

and welding rates were chosen for the investigation, by [10]. It was observed that square pin profile gave preferable weld quality over the other profile. Mechanical properties of the friction stir welded dissimilar aluminium alloy joints was studied by [11]. Dissimilar (5083 & 6061 sheets) FS welded joints were fabricated by varying the process parameters like rotational speed, traverse speed and axial force fixing the AA 5083 on the advancing side and AA 6061 on the retreating side. Two levels of these parameters have been chosen at 1000 rpm and 1600 rpm, 40mm/min and 160 mm/min and 2.5kN and 3.5kN for rotational speed, traverse speed, and axial force respectively. When the axial force is increased, the tensile strength is increased. This behaviour is due to the increased frictional heat and insufficient frictional heat. Higher weld results in faster cooling of the welded joints. In the present investigation the tensile strength and the hardness are observed to be more due to the ageing of the welded joints.

II. EXPERIMENTAL PROCEDURE

speeds results in poor heat generation and plastic flow of the material. This may have resulted in a weak interface at the joint. Higher the weld speeds lower the heat generation which

A. Material

The plates of 6 mm thickness AA5083-H111 aluminium alloy were cut into size 100 mm x 60 mm and machined with square butt joint configuration. The initial configuration was obtained by securing the plates in butt position using specially designed and fabricated fixture. Welding was carried out in a single pass using non-consumable tools made of High Speed steel. The chemical composition of the AA5083-H111 material used in the present study is given in Table I.

TABLE I
CHEMICAL COMPOSITION OF AA5083-H111 IN WT %

TABLE II FSW PROCESS PARAMETERS									
Process Parameter		Values/Types							
Material used		AA5083							
Type of Joint		Butt joint							
Thickness of the material (mm)		6							
Tool rotation speed(rpm)		600, 800, 1000							
Traverse speed(mm/min)		40, 160							
Dwell time(sec)		10, 20, 30							
Material	Mg	Mn	Si	Cr	Fe	Zn	Ti	Cu	Al
AA5083	4.5	0.7	0.4	0.15	0.4	0.25	0.15	0.1	Rest

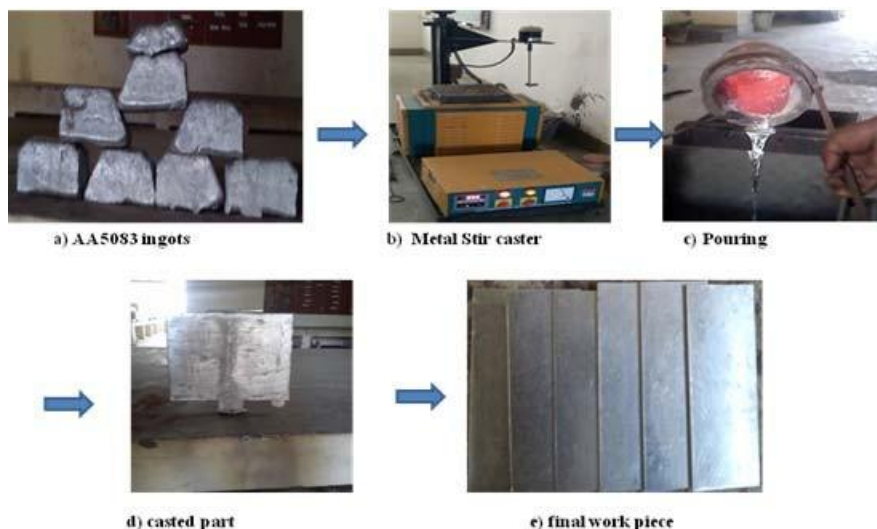


Fig. 2 Step by step procedure of material preparation

B. FSW

The welding was carried out in a 5-axis friction stir welding machine. Three different tools, viz Tapered unthreaded with cylindrical shoulder, Tapered Threaded with cylindrical shoulder, Triflute with cylindrical shoulder were used to fabricate the joints. Based on the literature, with availability of speeds on the machine, three different rotational speeds were selected to carry out the experiment. The welding parameters and tool dimensions are as shown in Table II.



Fig. 3 Friction Stir Welding Machine (Courtesy-IISc, Bangalore)

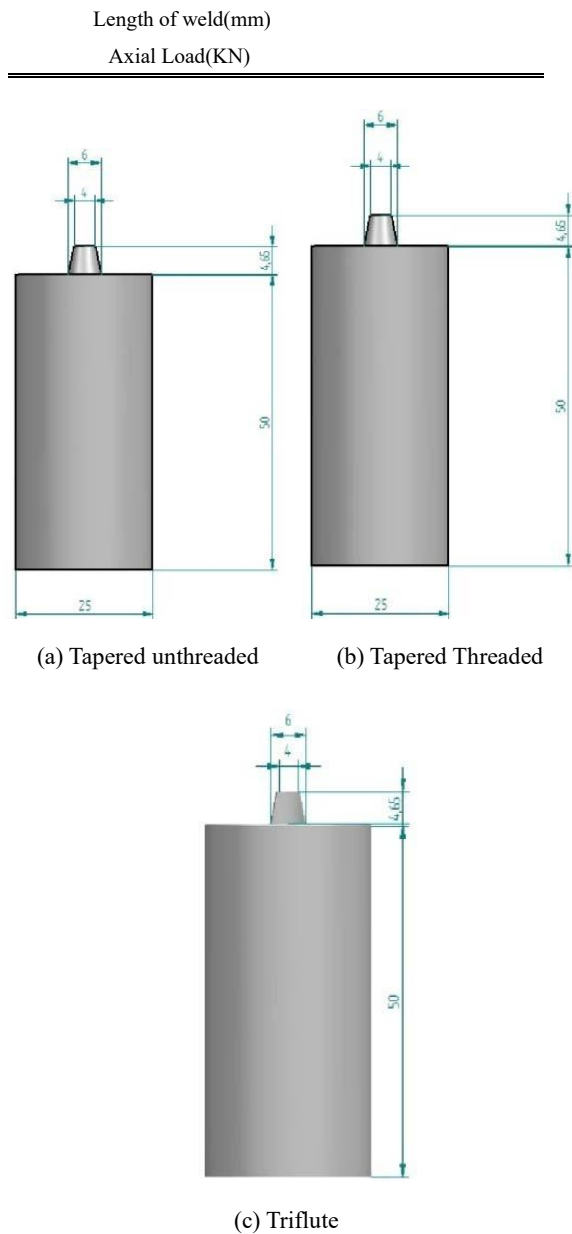


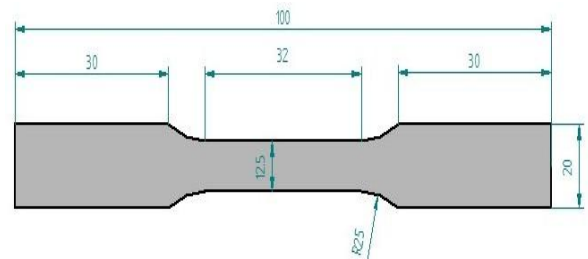
Fig. 4 Different tool profiles used

C. Methods

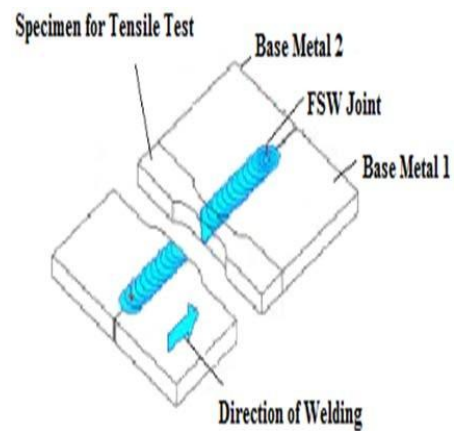
After FSW, the samples were cut to the required dimensions in order to prepare tensile specimens as shown in Fig. 5. ASTM E-13M guidelines were followed for preparing the tensile test specimens. Tensile test was performed to evaluate the mechanical properties of the joints. By using Universal Testing Machine (TUE-C-400) (40 T capacity), ultimate tensile strength of the specimens was recorded. The hardness of the weld samples was measured transverse to weld direction in such a way that it covers each and every zone generated at the both side of weld, i.e. advancing and retreating side. The load applied was 50gms. After welding the microstructure analysis of AA5083-H111 friction stirred channel was carried out with help of optical microscope. Keller’s reagent was used as etchant for the development of microstructure.

TABLE III
TOOL PARAMETERS AND DIMENSIONS

Parameters	Tool 1	Tool 2	Tool 3
Profile	Tapered unthreaded	Tapered Threaded	Triflute
Material	HSS	HSS	HSS
Shoulder diameter, mm			
Pin Diameter at Base, mm			
Pin Diameter at Tip, mm			
Pin Length, mm	4.7	4.7	4.7
Shoulder length, mm			
Plunge Depth, mm	4.8	4.88	4.84
Tool tilt angle, deg			
Side of weld	Single sided	Single sided	Single sided



(a) Tensile test specimen as per ASTM Standards



(b) Test specimen prepared perpendicular to FSW joint

Fig. 5 Tensile Specimen

III. RESULTS AND DISCUSSIONS

A. Non-Destructive Testing

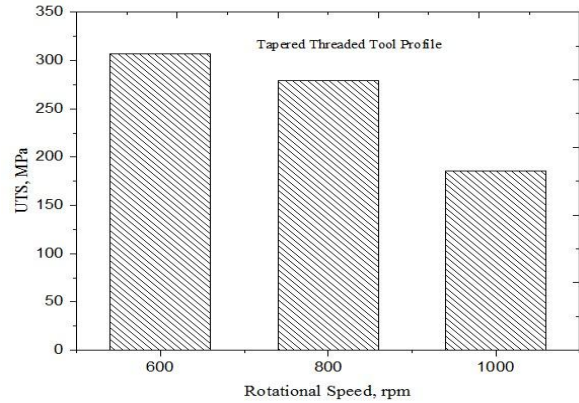
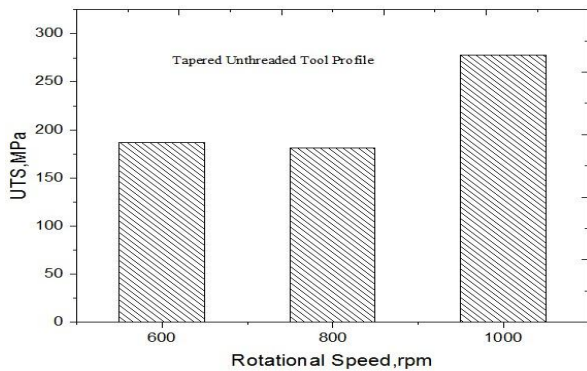
The friction stir welded samples were first visually inspected. Almost, all the joints welded with FSW were produced with a smooth surface finish. As a result of visual inspection on welded plates, surface type errors such as too much flash, galling, and lack of penetration have not been seen. When welding tool arrived at the end of the joint, it was allowed to run out the end of the workpiece, producing a tear out. These tear outs was trimmed away by sawing before further destructive tests. The welded joints are inspected visually by naked eyes to find the surface defects.

B. Tensile Test

After FSW all the specimens were tested to find out their ultimate tensile strength. Three specimens were tested for each combination of parameter and their average values were considered. All the results were plotted in the form of a bar chart ultimate tensile strength v/s Rotational speed as shown in Fig. 7. From the results of tensile test it can be studied that the ultimate tensile strength of the friction stir welded joint has been influenced by the tool profile of the welding tool.

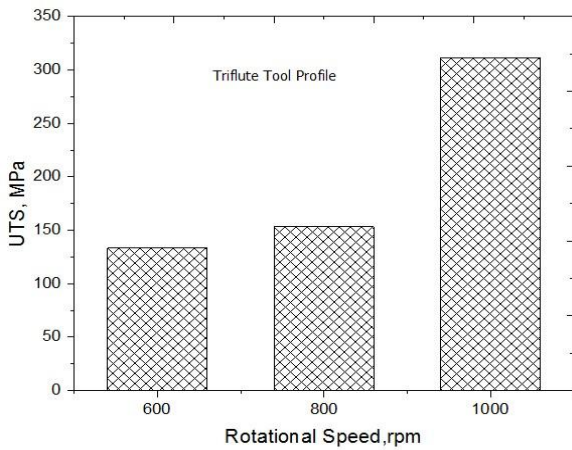


TABLE IV
TENSILE TEST RESULTS



(a) UTS vs Rotational speed for Tapered Unthreaded tool
(b) UTS vs Rotational speed for Tapered threaded tool

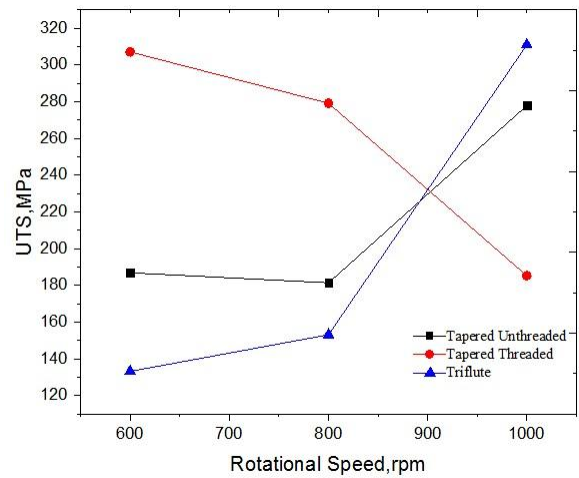
Tool	Surface morphology	Rotational speed, rpm	Yield Tensile Strength (MPa)	Ultimate Tensile Strength (MPa)	Percentage Elongation (%)
T1			159.99	186.88	2.6
T1			154.03	181.40	3.58
T1			203.65	277.82	11.73
T2			200.72	307.07	19.80
T2			186.28	279.09	10.30
T2			151.95	185.23	3.78
T3			99.72	133.18	1.75
T3			129.78	153.14	3.52
T3			176.08	310.91	19.88



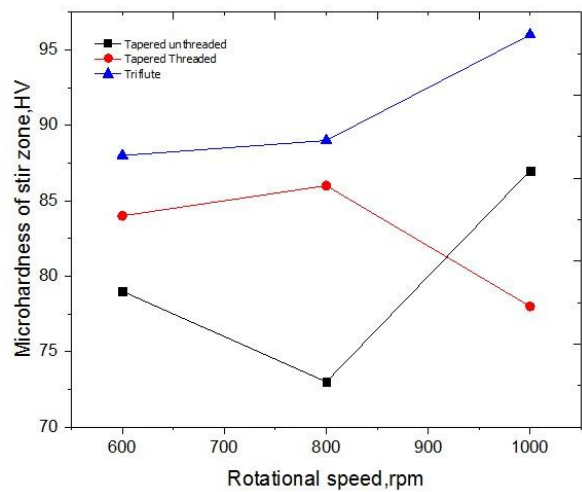
(c) UTS vs Rotational speed for Triflute tool

Fig. 7 (a)-(c) UTS vs Rotational speed for the tools used

The percentage change in the tensile strength is found to be 48.62% for Tapered unthreaded tool as the welding speed increases from 800 to 1000rpm, 65.77% for Tapered threaded and 33.36% for Triflute tool speed increases from 600 to rpm. It has been observed that the variation in tensile strength occurs for different tool profiles. The decrease in tensile strength has been found for tapered unthreaded tool profile and it has been increased for triflute tool profile in comparison with threaded tapered and Triflute. Different torque generated by Triflute profile may be responsible for increase in tensile strength, in comparison with rest of the profiles. The joint produced by using Triflute profile tool has given superior tensile properties as compared to Tapered unthreaded & Threaded tool for 1000rpm.



(a)



(b)

Fig. 9 (a) UTS vs Rotational speed, (b) Microhardness vs Rotational speed for the tools used

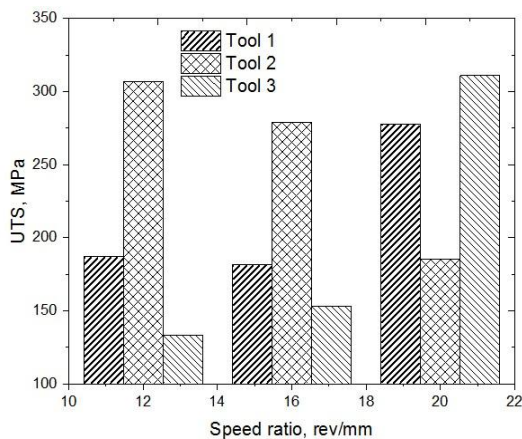


Fig. 8 UTS vs speed ratio for the tools used

C. Microstructure Results - Effect of Welding on Structural Properties of AA5083

Assessment of structural properties at different zones of the weldments using optical microscope was carried out. Microstructure of base metal consists of fine precipitates of alloying elements dispersed in the matrix of aluminium solid solution.

The grain size is small at the top of the weld, which was in region of the tool shoulder. The small size grains are obtained in case of triflute tool profile in correlation with Tapered unthreaded and threaded tool profiles. Small sized grains crosswise over entire weld shows that, high friction input is responsible for heating the weld over the temperature of recrystallization where the grain development happens. Uniform grain growth can be seen at high speed, 1000rpm in the event of Triflute tool profile, because of higher friction heat input and the tool profile may be responsible for exerting uniform heat input across the weld. From the above information it can be assessed that triflute tool profile operated at higher speeds may contribute in increase in mechanical and structural properties.

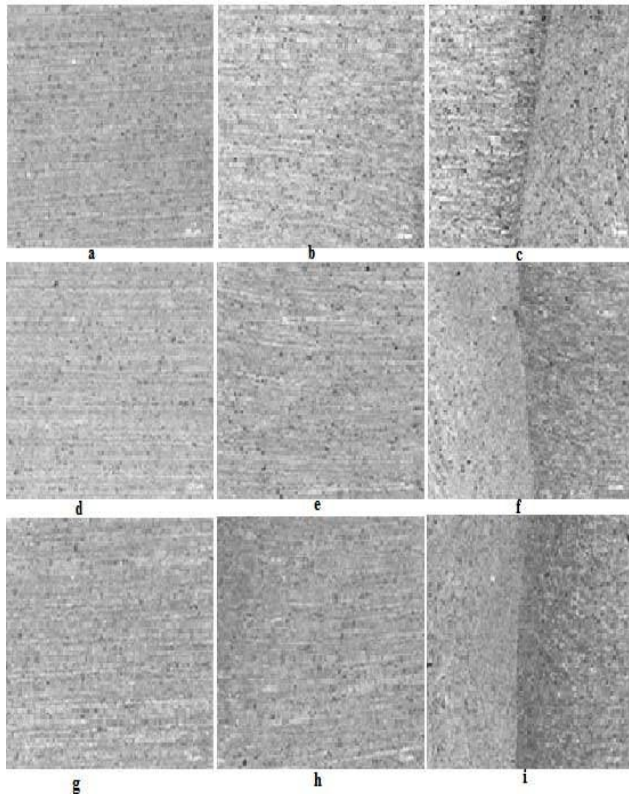


Fig. 10 (a)-(i) Tapered unthreaded, R S- 600rpm (a)-(c), 800rpm (d)-(f), 1000rpm (g)-(i)

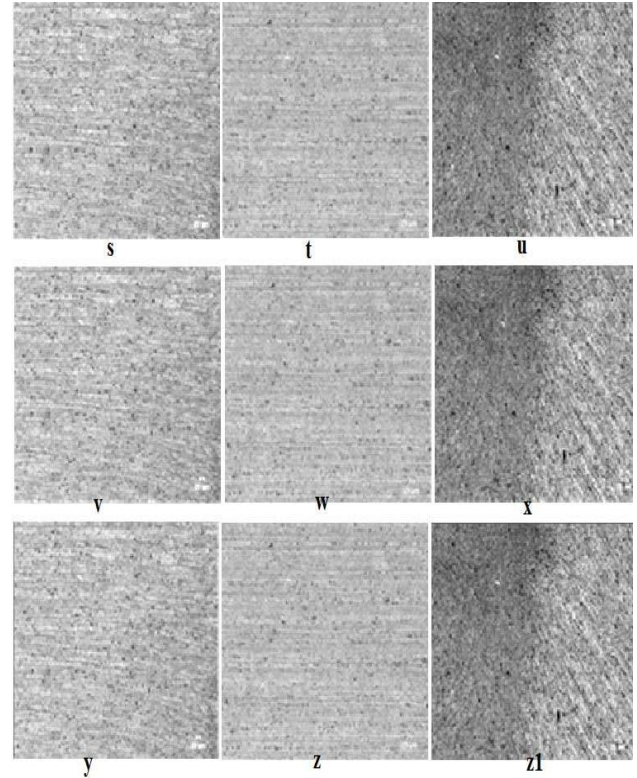
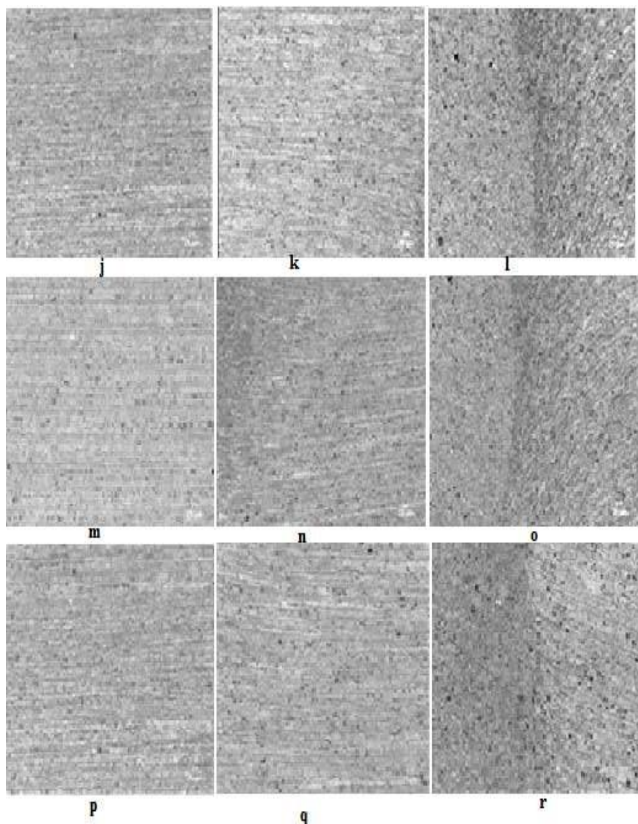


Fig. 10 (s)-(z1)Triflute, R S- 600rpm (s)-(u), 800rpm (v)-(x), 1000rpm (y)-(z1)



IV. CONCLUSIONS

From the investigation, it has been found that:

- For aluminium 5083, at 1000 rpm, tapered unthreaded tool profile is found to be the optimum tool, at 600 rpm, tapered threaded tool profile is found to be the optimum tool, at 1000 rpm, Triflute tool profile is found to be the optimum tool.
- It has been observed that the variation in tensile strength occurs for different tool profiles. The percentage change in the tensile strength is found to be 48.62 % for Tapered unthreaded tool as the welding speed increases from 800 to 1000rpm, 65.77% for Tapered threaded and 33.36 % for Triflute tool speed increases from 600 to 1000rpm. The decrease in tensile strength has been found for tapered unthreaded tool profile and it has been increased for triflute tool profile in comparison with other profiles.
- Assesment of structural properties at different zones of the weldments using optical microscope was carried out. Microstructure of base metal consists of fine precipitates of alloying elements dispersed in the matrix of aluminium solid solution.

REFERENCES

- [1] Thomas W.M, Nicholas E.D, Needham J.C, Murch M.G, Temple smith P and Dawes C.J, Friction stir welding, International patent application No.PCT/GB92102203 and Great Britain patent application No. 9125978.8, 1991.
- [2] R.S. Mishra, Friction Stir Welding and Processing, Materials Science Fig. 10 (j)-(r) Tapered threaded, R S- 600rpm (j)-(l), 800rpm (m)- and Engineering R, 50, Pp 1-78, 2005.
(o), 1000rpm (p)-(r)
- [3] M. Koilraj, V. Sundareswaran, S. Vijayan and S.R. Koteswara Rao, Friction stir welding of dissimilar aluminum alloys AA2219 to AA5083 Optimization of process parameters using Taguchi technique, Materials & Design, Vol. 42, Pp 1-7, 2012.
- [4] N.T. Kumbhar and G.K. Dey and K. Bhanumurthy, Friction Stir Welding of Aluminium Alloys, Barc News letter, Issue no. 321, Pp 1117, 2011.
- [5] T. DebRoy and H. Bhadeshia, Friction stir welding of dissimilar alloys - a perspective, Sci Technol Weld Joining, 15(4), Pp 266-270, 2010.
- [6] M. Peel, A. Steuwer, M. Preuss and P. J. Withers, Micro-structure, mechanical properties and residual stresses as a function of welding speed in aluminium AA5083 friction stir welds, Acta Materialia, 51, Pp 4791-4801, 2003.
- [7] Maen M. Al-rashdan, Influence of friction stir welding process and tool shape on strength properties of aluminium alloy joints, Recent advances in Industrial and manufacturing technologies, ISBN: 978-1-61804-1869, Pp 25-29.
- [8] S. Sattari, H. Bisadi, and M. Sajed, Mechanical Properties and Temperature Distributions of Thin Friction Stir Welded Sheets of AA5083, International Journal of Mechanics and Applications, 2(1), Pp 1-6, 2012.
- [9] L. Karthikeyan, M. Puviyarasan, S. Sharath kumar and B Balamugundan, Experimental studies on Friction stir welding of AA2011 and AA6063 aluminium alloys, international journal of advanced engineering technology, e-issn 0976-3945, vol.iii, issue iv, Pp144-145, 2012.
- [10] L.V. Kamble, S.N. Soman and P.K. Brahmanekar, Effect of Tool Design and Process Variables on Mechanical Properties and Microstructure of AA6101-T6 Alloy Welded by Friction Stir Welding, IOSR Journal of Mechanical and Civil Engineering, ISSN(e) : 2278-1684, ISSN(p) : 2320-334X, Pp 30-35.
- [11] Ramaraju Ramgopal varma, Abdullah bin ibrahim, Mohammed, Arifpin bin mansor, Mechanical properties of the friction stir welded dissimilar aluminium alloy joints, proceedings of 3rd international conference, pune, ISBN: 978-93-82702-62-7, Pp 1-5, 2014.