

Advancements in Renewable Energy Technologies

Elena Vasquez, Julian Styles

University of Technology, London, United Kingdom

Abstract—This paper presents comparative analysis of photovoltaic systems (PVS) and propose practical techniques to improve operational efficiency of the PVS. The best engineering and construction practices for PVS are identified and field oriented recommendation are made. Comparative analysis of central and string inverter based, as well as 600 and 1000VDC PVS are performed. In addition, direct current (DC) and alternating current (AC) photovoltaic (PV) module based systems are compared. Comparison shows that 1000V DC String Inverters based PVS is the best choice.

Keywords—Photovoltaic module, photovoltaic systems, operational efficiency improvement, comparative analysis.

I. INTRODUCTION

ENVIRONMENTAL concerns and global warming [1], the ever growing prices of scarce and exhausting fossil fuels [2], increasing energy demand [3], non-sufficient conventional production, lack of access to power [4], aging grid infrastructures, energy supply, and reliability & security concerns [5] are all pushing towards one source of energy, the renewable energy (RE). RE is abundant, naturally replenishable and has no or very limited environmental footprint. Therefore, innumerable technologies have been developed to convert RE resources, such as wind and solar, into usable form of energy in general, and electricity in particular. Having this in mind, individuals, businesses, utility companies and governments are all heavily investing in the field of renewable energy to keep the future Power Electric Grid (PEG) reliable, cost-effective and environment friendly. Global energy, especially electrical power generation, distribution and utilization, is being reshaped by RE resources at all levels.

Solar and wind energy have seen tremendous growth worldwide [6], [7] with solar energy doubling every two years, reaching 450 GW by 2017 [6]. The solar power reaching the earth (approximately 170 PW) exceeds all perceivable future demands of mankind, if harnessed properly [8]. Solar energy is converted into electricity using Photovoltaic (PV) or thermal technology, and into heat by solar heating technology. PV technology uses flat plate PV modules, usually made of semiconductor silicon, to convert sunlight into electrical energy.

Realizing the potential of this free and abundant environment friendly source of energy, researchers and manufacturers throughout the world have focused on the field of solar technology, especially PV since it has no moving

added inverter to supply the AC load [10]. Modelling and designing these components of PVS have been the topic of research for the past few decades with a variety of models reported in the literature. PV module on cell level is reported in [11], on module level in [12], battery in [13], BESS in [14], chargers with maximum power point tracking in [15] and inverter in [16].

PVS can be DC module [17] or AC module [18] based, and single phase [19] or three phase [10]. Similarly, PVS can be operated stand-alone (off-grid) [20] as well as grid tied (on-grid) [21]. Central inverter (CI) based PVS contain one or more large inverter(s) connected to large arrays [19] while string inverter (SI) based PVS contain several smaller SIs [18]. Each SI is connected to its own sub-array instead of single module unlike MI in [18].

The literature presents a variety of approaches to discuss, model and control a PVS but stay short of practical and field oriented discussions, analyses and solutions. This paper looks at PVS from practical perspective to bridge the gap between theory and application, and recommends techniques and solutions to achieve efficient and cost effective operation. The rest of the paper is organized into the following sections: (II) PVS, (III) DC vs. AC PVS, (IV) String vs. Central PVS, (V) 600V vs. 1000V DC PVS, (VI) Simulation Results, and (VII) Conclusions.

II. PHOTOVOLTAIC SYSTEMS (PVS)

PVS convert solar irradiance into DC power using PV modules (Fig. 1). The module contains a bunch of PV cells. Since cells are connected in series, the current remains the same while the module's voltage grows. The number of series connected and thus the application specific total number of cells in a module are determined using (1), where n_s = number of series cells, v_{pvc} = cell voltage and V_m = module voltage. In addition, PV module (and cell) current, I_m , is given by (2), where I_L = module produced photo current, I_D = diode reverse saturation current, I_{pv} = PV cell current (equals to I_m), V_{pv} = PV cell voltage (equals to V_m), q = Electron charge, n = Diode ideality factor, k = Boltzman constant and T = Temperature in degrees kelvin. For an ideal PV cell and thus PV module with no loss, (2) can be re-written as (3). Module DC power, P_m , can be given by (4):

$$(1)$$

$$I_m = I_L - I_D \exp\left(\frac{qV_m}{n k T}\right) \quad (2)$$

$$(3)$$

$$(4)$$

parts, requires little to no maintenance, and has easy and modular installation. In a PV system (PVS), the energy is converted through the PV module with charging DC-DC regulators and a battery to supply the DC load [9] or with an

If modules are connected in series (N_s), then voltage grows up while current remains the same. The total voltage of series connected strings, V_s , is given by (5). Similarly, if modules are connected in parallel (N_p), then current builds up while the voltage remains the same. The total current of parallel connected modules or strings, I_p , is given by (6). Similar to (4), PV array DC power is given by (7). Equations (5) or (6) or both can be used to build up PV array DC power (P_{DC}) to the required level, as given by (7):

$$(5)$$

$$(6)$$

$$(7)$$

irrespective of irradiance and temperature variations. DC-DC Boost Converter (BC) provides fixed DC voltage (V_{vsi}) equal to or greater than $\sqrt{2}V_{sys}$ (system voltage) at the input of VSI for satisfactory operation. During operation this voltage continuously varies due to temperature (and to very small extent irradiance) and BC keeps voltage fixed at the required level defined by (8)-(10) [18]. The Perturb and Observe (PO) MPPT algorithm adjusts duty cycle (D) to operate BC based on the prevailing irradiation and temperature to ensure fixed voltage at VSI input. In addition, MPPT operates array (or module) at maximum power (P_{DC-mp}) [18] given by (11) with maximum point V (V_{mp}) and I (I_{mp}). BC and MPPT are commonly internal to VSI at present.

$$\sqrt{2}V \tag{8}$$

$$— V = — \tag{9}$$

$$— \tag{10}$$

$$(11)$$

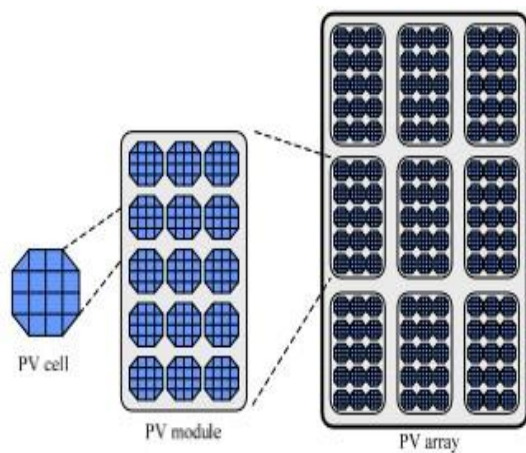

Fig. 1 PV Cell, Module and Array

The output voltage and produced current of a PV module not only depends on the type and area of the cell and the number of cells in series, but also on irradiance and temperature. The output voltage of an individual module is usually less than 50V and varies inversely with changes in temperature. Thus, a PV module has the highest output voltage for the lowest temperature in winter and the lowest output voltage for the highest temperature in summer. Similarly, a PV module output current is usually less than 10A and varies directly with irradiance (light). Hence, module current is highest in the full light and lowest (practically zero) in the dark. It is important to note that the heat (temperature) component of the irradiance causes wastage in PV modules and systems. Thus, with full light a PV module performs better in winter than in summer due to the lower temperature component in winter. Similarly, a PVS will generally perform better in Canada than in Egypt. This should not be confused with the fact that Egypt may have more hours of operation and therefore more overall production. Note that soiling such as dirt, snow and shade also reduce PV module output. Therefore, modules are usually, equipped with bypass diodes.

A PV array is connected to DC-DC converter for voltage and current adjustments to ensure optimum operation through maximum power point tracking (MPPT) control algorithm

VSI is used to convert DC power into AC power at operating voltage and frequency of the load and/or Point of Common Coupling (PCC) at the PEG. The number of switches (normally 4 for a single phase and 6 for three phase VSI) is controlled to adjust the output voltage and frequency to match the load and/or PEG voltage and frequency. Antiparallel diodes are connected across switching devices to allow reverse current flow. Proper operation of the bridge requires that no two switches of the same leg be turned on or off simultaneously to avoid short circuit or floating voltage, respectively.

The output voltage is controlled by Pulse Width Modulation (PWM), Space Vector PWM (SVPWM) or Model Predictive Control (MPC) [22] or other similar methods. The focus is on chopping DC at input to produce pulses, which are then filtered to obtain AC at the output. In sinusoidal PWM, for example, the on and off commands for switches are produced by comparing a modulating signal (V_{mod}) with a triangular or sawtooth carrier wave (V_c) to produce appropriate gating sequence for the switches. The frequency of the carrier wave (f_c) is selected higher than the frequency of the modulating signal (f_m), equal to or 10 times greater than f_m , for easier filtering of harmonics. VSI rms output voltage is defined by amplitude of V_{mod} and output frequency by f_m . Both the unipolar (using one carrier wave) and bipolar (using two carrier waves) PWM techniques are employed; however, the latter is preferred due to ease of implementation.

The output voltage for single phase VSI is given by (12), with V_A and V_B given by (13) and (14):

$$(12)$$

$$\frac{1}{T}V \tag{13}$$

$$= \left(\frac{t_{off}}{T}\right)V \tag{14}$$

Using (10), (13), (14) and (15), (12) can be re-written as (16):

$$2 I \tag{15}$$

$$2 I \tag{16}$$

Finally, if power of VSI is known, then the output current is given by (17) where subscript o represents output and L represents loss.

$$/ \quad / \quad / \tag{17}$$

Alternatively, the output power can be calculated by (18) using V_o and I_o . With power factor (PF) given by (19) and equal to 1 for PVS and representing efficiency of VSI by (18) is re-written as (20):

$$\tag{18}$$

$$\tag{19}$$

$$\tag{20}$$

Similarly, line (V_{LL}) and phase (V_p) voltage for three phase VSI are given by (21)-(26):

$$\tag{21}$$

$$\tag{22}$$

$$\tag{23}$$

$$\tag{24}$$

$$\tag{25}$$

$$\tag{26}$$

The three phase power is given by (27) and individual phase power by (28):

$$\phi \quad \sqrt{3} \tag{27}$$

$$- \phi \tag{28}$$

Output current can be calculated using (29) or (30):

$$\phi/\sqrt{3} \tag{29}$$

$$- \phi/ \tag{30}$$

DC input power of a three phase VSI can be related to ac output power of VSI by (31):

$$\tag{31}$$

IEEE 1547 as well as building, electrical and safety standards and codes set by authorities having jurisdiction (AHJ), for example, energy regulating board, building department, electrical safety authority, local distribution company, etc., have to be complied by in PVS. Central and string inverters connecting into PEG have to be certified and approved for the application according to the codes set forth for compliance. One of the compliance requirements, as pointed earlier, is that the PVS has to match its output voltage and frequency to the voltage and frequency of the PCC of the PEG before exporting any power. Another requirement is that once operational PVS continue to monitor PCC voltage and frequency for any disturbances or abnormality, and disconnect in case of any anomaly to ensure anti-islanding. Furthermore, even when disconnected due to voltage and/or frequency anomaly, PVS will continue to monitor EPS voltage and frequency to identify PEG revival to normal operation, for power export. In addition, re-connection for export is not allowed before a defined period (minimum 5 minutes) of steady state voltage and frequency restoration has passed. The normal voltage and frequency for PEG is a defined band around PEG nominal voltage and frequency (usually $\pm 10\%$ for voltage; for frequency however, the percentage is defined based on the kW size of PVS) [23].

IEEE-1547 also prohibits operation of the PV system (antiisland) when: a) PEG voltage at PCC is less than the lower or greater than the upper limit of voltage, and b) PEG frequency deviates away from the lower and upper limits of frequency, both defined per PV system kW size. Additionally, there are other requirements for power quality, monitoring, protection, etc. to ensure safe and reliable operation. For example, Schneider Electric 18 and 25kW string inverters [24] for PVS show operating voltage range as 244-305V/422-528V and frequency range as 57-63 Hz with a nominal voltage of 277/480V and nominal frequency of 60 Hz. Thus, these inverters stop operating if PEG voltage goes below the lower limit of $244V_p/422V_{LL}$ or above the upper limit of $305V_p/528V_{LL}$. Similarly, these inverters stop operating if PEG frequency falls below 57 Hz or exceeds 63 Hz. It is worth noting that usually these limits are programmable. AHJ requirement or other reasons may trigger a change of upper and lower limits, however, reporting is required if limits changed.

The minimum components for PVS are PV modules, cables, and inverter(s) (Fig. 2). However, based on the type of PVS and AHJ requirements, certified and approved DC Combiner (CB) and Re-Combiner (RCB) boxes, fuses/circuit-breakers, DC

disconnects, transformer(s), AC splitters, AC disconnects, enclosures, metering cabinet, revenue metering, and Supervisory Control And Data Access (SCADA) system may be required for safety and compliance. Additionally, local storage and monitoring systems may also be employed.

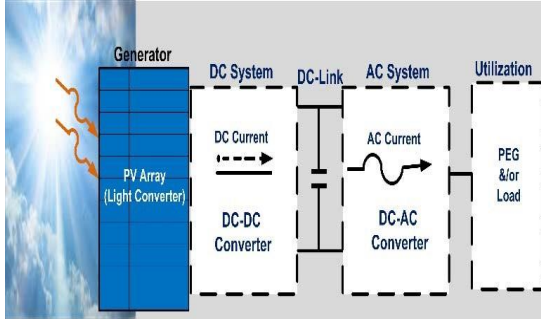

Fig. 2 The Minimum Components of PVS

No PVS or any of its components is perfect, thus all PVS have associated losses. Three main types of losses are irradiance (light), DC (electrical) and AC (electrical). Irradiance losses occur at the module level due to light reflection of the surface of module, soiling (dirt, snow), shade, etc. DC losses occur across array, DC-DC converter and associated components on DC side of PVS due to modules mismatch, cables resistance, converter efficiency, etc. AC losses occur across inverter and associated components on the AC side of PVS due to inverter inefficiency, cables resistance, etc. Generally, the accepted amount of PVS losses is 20%.

PV array is usually 20% over sized to compensate for the losses outlined. 120% to 140% oversize inverters are common, although some AHJ restrict inverters to 120% oversize). It is important to note that regardless of the oversize, the export to PEG can never be more than the inverter kW size. Thus, 120% oversize compensates for 20% losses and ensures 100% export to PEG. This leaves more than 120% oversize useless; however, one has to realize that solar irradiance is not at its full all day and thus PVS does not produce 100% power all day. For example, production of PVS is lower in the mornings and evenings when solar irradiance is not at its full and sun is at angles that cause higher amount of reflections. Thus, oversize beyond 120% can increase the power export, especially in mornings and evenings when irradiance is low and PV array cannot produce maximally.

Sizing fuses/circuit-breakers and cables should comply with the codes to ensure safety and ensure efficient operation. Two parameters to consider are voltage drop across and power losses along the sized cables. DC or single phase voltage drop is given by (32) and 3 phase voltage drop by (33), where L is cable length and R_{spec} is resistance of cable per km.

$$2 \quad 2 \quad /1000 \quad (32)$$

$$\phi \sqrt{3} \quad \sqrt{3} \quad /1000 \quad (33)$$

Similarly, DC or single phase power losses are given by (34) and three phase power losses by (35):

$$/1000 \quad (34)$$

$$\phi \sqrt{3} \sqrt{3} \quad /1000 \quad (35)$$

A safety requirement recently emphasized by AHJ is phase loss detection by PVS. In other words, PVS is required to detect single open phase loss on the PEG side of the customer owned transformer and anti-island. If PVS fail to detect phase loss and continue to operate with unbalanced PEG, then in addition to positive sequence current a negative and/or zero sequence current will be created that can generate heat and result in equipment failure and/or initiate fire.

III. DC vs. AC PVS

PV systems can be broadly divided into DC-PV and AC-PV systems. CI and SI based PVS are DC-PV and micro-inverter (MI) based PV are AC-PV systems.

A. DC-PV PVS

A number of DC-PV modules are connected in series and in parallel to build higher DC voltage and current, respectively, resulting in desired DC power. Then DC-PV array is connected to PEG through MPPT BC, a DC-link capacitor, and PEG interactive VSI, as shown in Fig. 3. The system built as one or more arrays is combined by CB and RCB to connect into one or more CI or SI for conversion into AC. AC combiner/splitter is used to collect more than one CI or SI. Finally, a transformer is used for isolation and/or voltage stepup to connect AC splitter to PEG. The number of modules in a series-string is usually limited by the system's maximum V_{DC} (600V or 1000V); therefore, one has to deal with the high DC voltage and DC wiring expertise is required for proper sizing of the array and installations. The current in a string is defined by, and thus depends on, the weakest link in the string since modules are connected in series. DC Balance of System (BOS) such as DC fuses, cables, and disconnects are required. These add to the design complexity, equipment cost, losses and installation time.

B. AC-PV PVS

AC-PV PVS consists of AC-PV modules. AC module, as defined by the National Electrical Code, is a complete, environmentally protected unit consisting of solar module (or cells), a micro-inverter (MI) and other components, exclusive of a tracking system, designed to produce AC power from the sun irradiance. AC modules are required to be tested by a recognized laboratory using both UL 1741/1703 as a single unit. As shown in Fig. 4, AC-PV module is a DC-PV module with an integrated MI that produces AC voltage and current at PEG frequency and voltage.

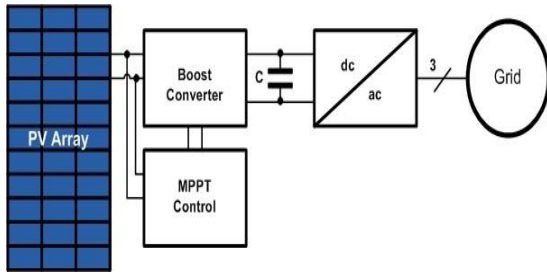

Fig. 3 DC-PV PVS

AC-PV PVS does not require sizing an array (no series or parallel strings). Furthermore, in an AC-PV PVS there is no loss due to modules mismatch, no DC BOS, very small amount of DC losses, optimal shading/soiling/snow operation, and no single point of failure. In an AC-PV PVS there is no need to deal with high voltage, and the system's performance is not defined by the weakest link. Moreover, there is no need for transformers, big DC-link capacitors or cooling fan for inverters. Factory design, sizing and assembly give optimal performance that is usually difficult to attain in the field, and therefore save installation time. AC-PV PVS allows module level monitoring for performance and maintenance by default, integrated with MI. Although AC-PV PVS cost more than DC-PV PVS, they yield up to 25% more energy and are easier to design and install.

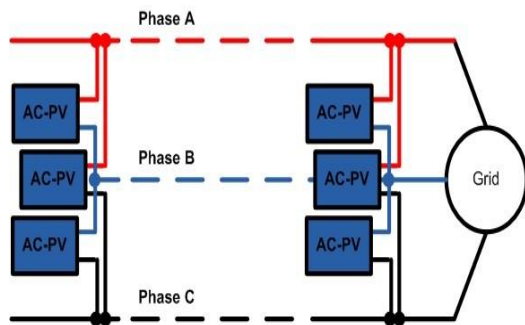

Fig. 4 AC-PV PVS

In AC-PV PVS a number of AC-PV modules are connected directly across PEG phases A, B, C and thus all the intermediary steps from PV array to the grid are eliminated. AC-PV modules are wired between two of the three phases. Equally distributing AC-PV modules across phases prevents imbalance within the 3-phase system. The number of modules in an AC-PV PVS is limited by the line's current capacity. For example, a 20A branch allows 17 AC-PV modules of 0.94A each ($17 \times 0.94 \approx 16A$) with a short circuit derated current of 20A ($16A \times 1.25 \approx 20A$), for a total of 51 AC-PV modules in an AC-PV PVS.

IV. CI vs. SI PVS

PVS can be built around CI as well as SI. Fig. 5 shows a CI based PVS. First, modules are combined into series of strings to build voltage. The strings are then put in parallel to build current in order to achieve the desired DC power. The desired DC power is usually 120% of the CI kW. Due to its size, the DC array is divided into sub-arrays each connected to its own CB. Several CBs are then

collected into one or more RCB. RCB(s) are connected to CI for DC to AC conversion. CI is connected to a transformer for isolation and/or voltage stepup. A CI PVS also requires fused DC and fused AC disconnects for safe operation of the system and isolation when required.

Fig. 6 shows an SI based PVS. Each sub-array is connected to its own SI. DC PV array is still oversized by 120%. All SIs are combined across AC-splitter to connect across transformer to be connected across PEG through AC disconnect. Note that in an SI based PVS there is no need for CB and RCB on the DC side; however, a splitter is required on the AC side before the transformer. The AC disconnects would normally be fused ones for safe isolation of the system whenever required.

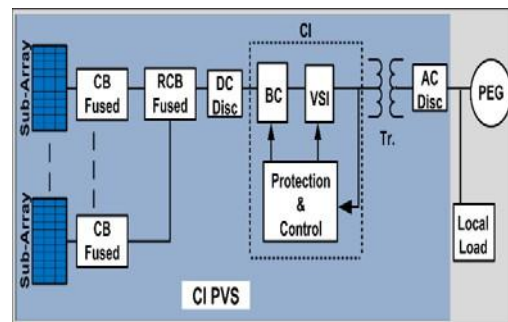

Fig. 5 CI PVS

V. 600V vs. 1000V DC PVS

A PVS is built with either 600 or 1000V DC. An appropriate CI or SI inverter will be required to operate at 600V or 1000V DC. In either case modules are used in series to build series string with voltage equal to or less than the target DC voltage, i.e., 600 or 1000V. Since 1000V is 40% greater than 600V, a 1000V PVS will ideally allow 40% more modules series connected in a string. Thus, if a 600V PVS allows 12 modules in series (each module 50V), then a 1000V PVS will allow 20 modules of the same voltage (40% more).

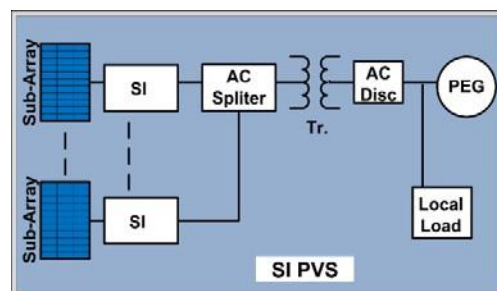

Fig. 6 SI PVS

Recall that a PV module is sensitive to both irradiance and temperature. Current is directly related to irradiance, and voltage is inversely related to temperature. Therefore, if the number of modules in a string is defined based on a temperature of hot summer or milder winter day, then the string's voltage can exceed PVS max DC voltage of 600 or 1000V on colder day. Therefore, the number of modules in a series string should be determined at the record lowest temperature for the site. This

ensures that the system’s DC voltage remains lower than the PVS DC voltage of 600 or 1000V, at all temperatures and all year round. Equations (36) and (37) are used if the parameters provided by the manufacturer are used to calculate the number of modules in series string, where V_{trans} represents module voltage at prevailing temperature, V_{oc} is open circuit voltage, C_v is the temperature coefficient, T_m is the present temperature, T_r is the reference temperature (25°C), N_m is the number of modules in series, and V_{ss} is series string voltage.

$$(36)$$

$$600 \quad 1000 \quad (37)$$

Equation (38) is used with code books such as the US National Electric Code. In this equation C_t is the correction factor which is obtained from the voltage correction factors table from NEC (Table 690.7, 2011 NEC).

$$600 \quad 1000 \quad (38)$$

VI. COMPARATIVE ANALYSIS

In this section we compare the aforementioned PVS in terms of design complexity, cost savings and operational efficiency. The pros and cons of different types of PVS are identified and the best course of action with optimal solution is proposed. We use a field-oriented practical approach and recommendations are made based on the authors’ years of academic and practical experience in the PV field. A two hundred and fifty (250) kW system is used as an example for this analysis. The market price of each component of the system is shown in Table I. Toronto, Canada is considered as a site for the system with the recorded lowest temperature of 30°C and a PCC of 600V and 60Hz. Commercially available 305W modules, 250kW CI, 25kW SI and 250W MI are considered for this system.

TABLE I
THE MARKET PRICE OF PVS COMPONENTS IN CENTS (CANADIAN)

Item	Cost	Item	Cost/W
Modules	0.77/W	AC Splitter	450.00
Racking	0.27/W	Transformer	0.035
12 Input CB 480.00 Non-Fused Metering Cabinet 1800		AC Disc. 500.00 RCB	1600.00
DC Disc.	350.00	Fused AC Disc.	900
250kW CI	0.176	250W MI	0.64
25kW SI	0.153	Monitoring	0.016
Fuse 15A	21.00	SCADA	1200.00
Fuse 125A	47.20	Fuse 200A	57.00
Fuse 300A	79.20	Fuse 400A	83.20

A. CI PVS with 600V DC

A 600V DC PVS allows 11 modules in series at lowest temperature with V_{oc} equal to 45.6V and VDC equal to 589.88V. To bring the PV array DC size as close as possible to 120% max allowed in Ontario, Canada, we will need 7 CBs of 11 strings with 11 module each and 1 CB with 12 strings of 11 modules each,

resulting in a 298595W (298.595kW) DC PV array. Thus, this system will have 89 parallel strings with 11 modules each, 8 CBs and one RCB to collect output of all CBs. The oversize or DC/AC ratio in this case would be 119.4%, little shy of 120% due to string size symmetry imposed by CI. The DC output of RCB will be connected to a single 250kW CI, usually through a DC disconnect, for conversion into AC. The output of CI will be connected across PEG through a transformer and an AC disconnect as explained before. DC and AC disconnects are normally fused ones. A CI PVS features are outlined in Table II.

B. SI PVS with 1000V DC

A 1000V DC PVS allows 18 modules in series at lowest temperature with V_{oc} equal to 45.6V and VDC equal to 965.26V. This PVS requires 10 25kW SI (250kW/25). Ideally, each SI can be oversized to 30 kW for a total of 300kW PVS; however, equal length strings requirements on each SI or individual MPPT inputs of SI would result in a PVS with less than 300kW. To bring the PV array as close to the 120% max allowed as possible, each SI may be loaded asymmetrically though and with string sizes less than max 18 modules. Thus, this system can be sized with 55 strings of 17 modules each and 3 strings of 16 modules each, resulting in a total of 299815W (299.815kW) DC PV array. Thus, this system will have 58 parallel strings with 17 & 16 modules. The oversize or DC/AC ratio in this case would be 119.9%. The output of all SIs will be collected across AC splitter and connected to the transformer. The transformer will be connected to PEG through an AC disconnect. The AC disconnects used are normally fused ones. SI PVS features are outlined in Table II.

TABLE II
COMPARISON TABLE

Item	CI PVS	SI PVS	MI PVS
DC Side			
PVS Size	298.6kW	299.82kW	299.75kW
Modules			
String Size		17 & 16	n/a
// Strings			n/a
Fuses			integral
CB			n/a
RCB			n/a
Disconnect			n/a
AC Side			
Inverters			
Splitter			
Transformer	1*		
AC Disconnect			
Misc.			
Inv. Eff.	96%	98%	96.5%
MPP Performance	Poor	Good	Best
Shade performance	Poor	Good	Best

*Transformer can be integrated and included in the CI cost

C. MI PVS with No DC

An AC-PV PVS consists of AC-PV modules. Therefore, 250kW PVS will be divided based on chosen AC-PV module power rating. The total number of MIs in the 250W AC-PV module commonly available in the market is 1000. However, since 1000 is not divisible by 3, the MIs cannot be distributed evenly across the three phases, therefore, only 999 MI or ACPV modules are used. This will result in a total DC size of 299700W (299.7kW) and an AC system of 249.750kW. Since output voltage of 250W MI is not 600V, PCC voltage for connection to PEG, therefore splitter and transformer will be required for voltage step-up. MI PVS features are outlined in Table II.

Tables I and II allow easy comparison of different PVS. It also helps identify the best option available in general and for specific applications. Using Tables I and II with prior discussions, following can be suggested:

VII. CONCLUSION

PVS based on CI, SI and MI were discussed and compared from theoretical, analytical and practical point of views. The pros and cons of each of these systems have been outlined. Several field oriented suggestions were made based on these analyses and practical experiences of the authors in the PV field. The overall cost, performance and maintenance analyses indicate that SI is the best option at present. Up to 40% savings on BOS and 2-3% efficient operation (2-3% more revenue) is possible with 1000V DC SI based PVS.

REFERENCES

- [1] A. Woodward, "Heat, cold and climate change", *Journal of Epidemiology and Community Health*, vol. 68, (2014).
- [2] S. Shafiee, and E. Topal, "When will fossil fuel reserves be diminished?", *Energy Policy*, vol. 37, (2009).
- [3] International Energy Outlook 2013, US Energy Information
- [4] M. Amin & P. F. Schewe, "Preventing Blackouts", *Scientific American*, (2007).
- [5] J. P. Dunlop, "Photovoltaic Systems", 2nd edition, (2010).
- [6] S. Anand, R. S. Farswan, B. Mangu, and B.G. Fernandes, "Optimal Charging of Battery Using Solar PV in Standalone DC System", *IET Intl. Conf., P. Electronics, Machines and Drives*, (2012).
- [7] L. Piegari and R. Rizzo, "Adaptive perturb and observe algorithm for photovoltaic maximum power point tracking", *IET Renewable P.*
- [8] T. Salami, M. Bouzguenda, A. Gastli, and A. Masmoudi, "Matlab/Simulink based modeling of solar photovoltaic cell", *Intl. J. of Renewable Energy research*, vol. 2, (2012).
- [9] V. Sangsawang and S. Chaitusaney, "Modeling of photovoltaic module from commercial specification in datasheet", *IEEE Conf. of Electrical/Electronic Eng., Comp., Telecom. and Info. Technology*, (2012).
- [10] P. H. L. Notten, and D. Danilov, "From battery modeling to Battery Management", *IEEE 33rd Intl. Telecomm. Energy Conf.*, (2011).
- [11] Z. Wang and H. Li, "Integrated MPPT and bidirectional battery charger for PV application using one multiphase interleaved three-port dc-dc converter", *26th IEEE Applied P. Electronics Conf. and Exposition*, (2011).
- [12] S. A. Lakshmanan, B. S. Rajpourhit, A. Jain, "Modeling and analysis of 3-phase VSI using SPWM technique for grid connected solar PV system", *IEEE Conf. on Electrical, Electronics and Comp. Science*, (2014).
- [13] I. M. Syed and A. Yazdani, "Simple Mathematical Model of Photovoltaic Module for Simulation in Matlab/Simulink", *Canadian Conf. on Elec. and Computer Engineering, IEEE*, (2014).
- [14] I. M. Syed and K. Raahemifar, "Alternating Current Photovoltaic Module Model", *Intl. J. of Elec., Comp., Electro., and Comm., Eng.* Vol:9, No:3, (2015)
- [15] I. M. Syed and K. Raahemifar, "Model Predictive Control of Single
 - 1: 120% oversize should be opted for, if AHJ permits, to compensate for 20% losses.
 - 2: Focus on growing the voltage by connecting as many modules as possible in series string to minimize current in the system:
 - a) Decreases I²R losses
 - b) Results in smaller and cheaper cables
 - c) Decrease // strings, thus, fewer and smaller fuses
 - 3: Size and define number modules in a string at lowest recorded temperature
 - 4: Coordinate string sizing with MPPT window of the inverter used
 - 5: Distribute the number of strings across inverter MPPT inputs equally if possible (un-equal use permitted too)
 - 6: A 1000V system is better than a 600V system:
 - a) Inherently inclusive of 2a, 2b, and 2c (above)
 - b) Requires 40% less BOS, thus labor and cost savings
 - 7: Focus on longer cables on DC side due to:
 - a) Voltage on DC side is usually greater
 - b) DC current uses cables fully (no skin effect)
 - 8: Do 1-Skip-Series-String wiring (where possible) to minimize loss due to inherent 1.8m – 2.6m leads of modules
 - 9: Landscape may be better than portrait in areas with snow
 - 10: Ensure V_{drop} along the lines are low on both DC and AC sides for optimum operation and interaction with the PEG and to avoid nuisance tripping of inverter, especially in country side
 - 11: Ensure P_{loss} along the lines is low by little oversize of cables ensuring 20 or more years of efficient operation
 - 12: Efficiency of SI is usually higher than both CI and MI
 - 13: SI performs better in shade and with snow than CI, but poorer than MI
 - 14: SI permits strings size asymmetry between inverters as well as between MPPT inputs of the same inverter, allowing for better oversize or DC/AC ratio as compared to CI
 - 15: O & M is easier with the SI as compared to CI and MI
 - 16: Downtime is partial and thus better with SI
 - 17: CI will require its own dedicated area, such as a fenced concrete pad
 - 18: Labor on SI PVS is usually less than on CI and MI PVS
 - 19: SI is cost competitive with CI and can save money compared to MI
 - 20: MI has almost all but at higher prohibitive per watt cost
 - 21: Maintenance is difficult with MIs integrated at the back of modules and dispersed throughout the field

Phase Inverter for PV System", *Intl. J. of Elec. Comp. Electro. and Comm. Eng.*, vol. 8, No:11, (2014).

[16] X. Zhu and Z. Liao, "Energy management for stand-alone PV system", *Intl. Colloquium on Computing, Communication, Control, and Management*, vol. 4, (2009).

- [17] Q. Kang, X. Xiao, H. Yi, and Z. Nie, "Energy management in grid connected PV systems with supercapacitor energy storage", Intl. Conf. on Electrical Machines and Systems, (2011).
- [18] I. M. Syed and K. Raahemifar, "Space Vector PWM and Model Predictive Control for Voltage Source Inverter Control", Intl. J. of Elec. Comp. Electro. and Comm. Eng., vol. 8, (2014).
- [19] IEEE Application Guide for IEEE Std 1547™, IEEE Standard for Interconnecting Distributed Resources with Electric Power Systems, IEEE Std 1547.2™-2008.