

Advancements in High-Temperature Composite Materials

Evelyn Sawyer, Julian Styles, Lucas Patel, Ava Moreno

Massachusetts Institute of Technology, Cambridge, USA

Abstract—Polyetherimide (PEI), an engineering plastic with very high glass transition temperature and excellent chemical and thermal stability, has been processed into a controlled porosity filter media of varying pore size, performance, and surface characteristics. A special grade of the PEI was processed by melt blowing to produce microfiber nonwovens suitable as filter media. The resulting microfiber webs were characterized to evaluate their structure and properties. The fiber webs were further modified by hot pressing, a post processing technique, which reduces the pore size in order to improve the barrier properties of the resulting membranes. This ongoing research has shown that PEI can be a good candidate for filter media requiring high temperature and chemical resistance with good mechanical properties. Also, by selecting the appropriate processing conditions, it is possible to achieve desired filtration performance from this engineering plastic.

Keywords—Nonwovens, melt blowing, polyetherimide, filter media, microfibers.

I. INTRODUCTION

THE need for better filter media for applications in liquid and gas filtration has increased in recent years. In particular, filters for biomedical applications, water filtration, oil and gas separation and other applications for reducing environmental pollution have become increasingly necessary. Whereas filter media are produced from variety of polymers or fibers using a wide range of processes, share of the nonwoven filter media in the industry has been steadily increasing. Nonwoven filters have particularly become attractive because of the simplicity in the fabrication process and does not use excessive raw materials or other chemicals that can present challenges during processing as well as in the end product. Of the several nonwoven processes, melt blowing is certainly the most attractive one for the manufacture of high quality filter media.

The melt blowing has become a commercially successful process in producing nonwovens because of its ability to produce fibers of desired characteristics including fiber diameter ranging from 2-4 microns, and desired permeability characteristics, which is achieved by manipulation of the processing conditions. It involves application of hot air jet to an extruding polymer melt, which is then drawn into micro

Vincent Kandagor was a PhD Student and Daniel Prather was an Undergraduate Student at the University of Tennessee, Knoxville, TN, USA. Ramesh Bhawe is a Senior Research Scientist at the Oak Ridge National Laboratory, Oak Ridge, TN, USA.

and nano size fibers [1].

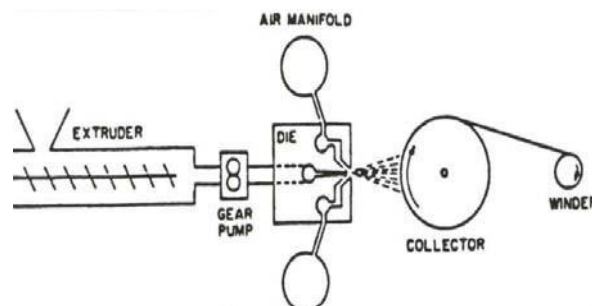

Fig. 1 Schematics of the melt blowing process [2]

The melt blowing technology, which was originally commercialized by the Exxon Chemical Company, is currently widely used for production of fine fiber nonwovens. The typical process schematic is shown in Fig. 1. The extruder melts the polymer, and the molten polymer is forced through the melt-blowing die which consists of a row of orifices or jets, resulting in the formation of small diameter fibers [2]. The fibers are then drawn by the high velocity hot air, quenched and collected on a continuous moving belt forming the continuous fiber web. The properties of the meltblown webs are affected by various production parameters including air temperature, polymer/die temperature, die to collector distance (DCD), collector speed, polymer throughput, air throughput, die hole size, and air gap [3], [4].

Several polymers such as polypropylene, polyesters, and polyethylene have been successfully meltblown using the pilot line, and many of them are commercially practiced [5], [6]. The polyetherimide (PEI) resin is a copolymer with the ether molecules between imide groups. The Ultem resin combines the high performance associated with the exotic specialty polymer together with the excellent processability characteristics of engineering polymers, and finds specific applications in the aerospace, automotive, and insulation industries, where performance at high temperatures is a stringent requirement [7]. Although Ultem has not been meltblown before, it has been converted into fibers and membranes [8], [9]. In this work, we have demonstrated the possibility of producing filter media from Ultem with high temperature, high chemical resistance, and high pressure operating range and evaluated them for their performance and physical properties.

II. MATERIALS AND PROCESSING

Commercially available PEI Ultem 1285, was purchased from Sabic Innovative Plastics, and was used without any further modification. The polymer was dried at a temperature of 130 °C for 6 hours to ensure that the moisture content was reduced to the recommended 0.02% before melt blowing. This Ultem had a

Melt Flow Rate (MFR) of 23 g/10 min at a temperature of 325 °C.

Meltblowing was performed using the 15-cm wide meltblowing line (Fig. 1) at the University of Tennessee's Nonwoven Research Laboratory (UTNRL). Multiple zones with independent heaters allow the incremental heating of the polymer to allow complete melting [10]. The Exxon type die used had 10 holes per cm and each hole was 450 µm in diameter. The die temperature was maintained around 365 °C and the air temperature slightly higher (~390 °C) to help maintain the die at the desired temperature. Since air pressure is the most critical variable in controlling the fiber diameter, three different air pressures were investigated, keeping rest of the processing conditions same. The primary variable in the production of these fibers was the air pressure because a slight variation in the temperature results in significant change in the permeability of the membrane compared to the variation of the air temperature or collection speed. It has been previously observed that, for fibers used in separation technology, the ideal air temperature for Ultem fibers is 390 °C. This is the main reason for varying the air pressure

The produced Ultem 1285 nonwovens were characterized to determine the pore size and pore size distribution. This was done using a Porous Materials Inc. capillary flow porometer model ASF-1100-AEX. The porometer measures the gas flow as a function of the applied pressure, and the curve that is determined for both the dry and wet measurements is used for the calculation of the pore size, mean flow pore size, the smallest pore size and the gas permeability of the resulting membrane. The Washburn equation has been used to define the mathematical relationship between the applied pressure and the pore size by using the surface tension and the contact angle of the wetting fluid providing the porosity data [11].

SEM micrographs were obtained using an ETEC Auto-scan scanning electron microscope at 3 keV after coating with a gold layer. The SEM images used in combination with a computer image processing software (ImageJ NIST) helped determine the average fiber diameter and fiber diameter distribution of the samples. The tensile properties of the nonwovens were tested using a United SSEM-1-E-PC tensile tester. Five specimens of each nonwoven sample were cut and the resulting values from the tensile testing were averaged according to the ASTM D638 - 10. The air permeability was measured using TEXTEST FX3300 equipment according to ASTM standard D737-96. The Mettler Differential Scanning Calorimetry (DSC) model - Mettler Toledo DSC821 was used to characterize the polymer meltblown fiber webs and the calendered membranes. The samples were heated at 10 °C/min from room temperature to 380 °C, held for 3 minutes at this temperature then cooled back to room temperature at 10 °C/min.

III. RESULTS AND DISCUSSION

The fiber diameter of meltblown Ultem has been characterized in detail, and the correlation between the fiber diameter and the processing air pressure reveals a relationship that is similar to those reported in literature [12], [13]. The lower the air pressure, the higher the resulting fiber diameter and the entangling of the

fiberweb. Theoretically, the fiber diameter will increase as the airflow rate decreases.

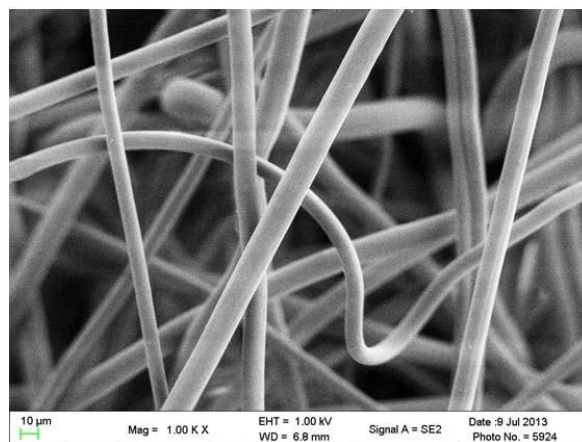

(A)

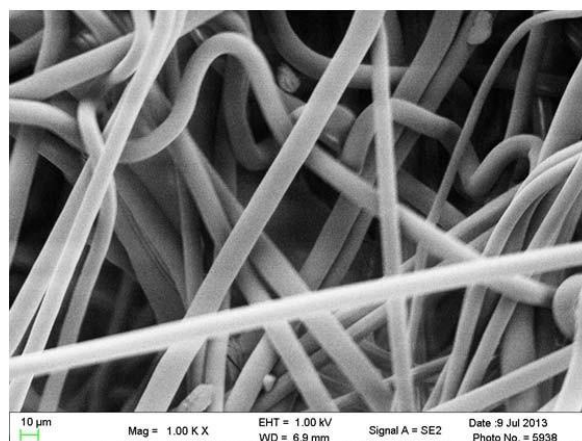

(B)

Fig. 2 SEM photographs of melt blown Ultem webs produced at 172 kPa (A) and 241 kPa (B) air pressures.

Fig. 2 shows the SEM photographs of webs produced under two different air pressures, and fiber diameter data are consistent with the expected results. At the 241 kPa of pressure, the average fiber diameter is about 9.5 µm, at 206 kPa, the fiber diameter increases to 10.5 µm, and at 172 kPa processing air pressure, the resulting fiber diameter was determined to be 12 µm. There is a linear relationship between processing air pressure and the resulting fiber diameter as shown in the graph below (Fig. 3).

The processing air has the most dominant effect on fiber attenuation. In fact, the drawdown of the fiber in the melt blowing process is due to the processing air and higher air pressure leads to acceleration of the molten polymer coming out of the die. That is how the polymer coming out of the die at 450 microns goes down to few microns within a short distance. The higher air pressure means an increase in acceleration of the filament leading to higher velocity and effective draw ratio.

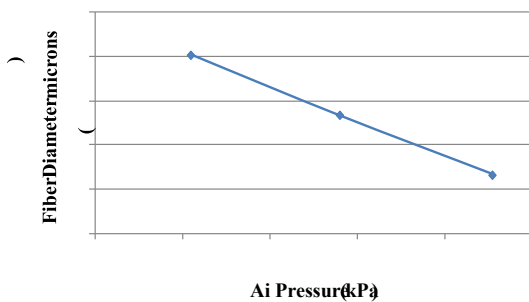

same range. Only because current day commercial PP resins for meltblowing are of special high melt flow rate type, finer fibers in the range of 2-5 microns are possible.

The SEM micrographs of the fiber webs (Fig. 2) show smooth fiber morphology that would confirm the relative ease in the processability of Ultem 1285 from the pellets by meltblowing, in spite of their high glass transition temperature and melt viscosity. There is no evidence of breaking up of the resulting fibers or variation in diameter along the length of the fiber, an indication of strong fiber web structural integrity. The fiber web formed at higher air pressure shows a lower fiber diameter but higher fiber volume per unit area, which results in a smaller effective pore size and separation characteristics.

The air permeability of the webs (Fig. 4) indicates that the smaller the thickness of the webs produced, lower the permeability because of significantly reduced pore size. This is mainly due to the reduction in fiber diameter with increasing air pressure used during melt blowing. Finer fibers lead to reduction in pore size better packing of the fibers, resulting in reduction in air flow rate through the webs.

Fig. 5 shows the change in average thicknesses of the webs. The change in thickness of the webs is due to the combined effect of fiber diameter and web consolidation. Reduction in fiber diameter leads to better packing of the webs, although there may be more fibers for the same basis weight. The webs will also have

much higher surface area. However, the fiber consolidation gets better and reduces the thickness. All of these lead to lower air permeability as explained before due to reduction in pore diameter from enhanced consolidation in the finer fiber webs.

Reproducible data show that the tensile strength of the nonwoven Ultem 1285 produced at the pressure of 241 kPa averaging 8 kN/m². The peak elongation for this sample was 11.1%. The tensile strength is a combined effect of fiber diameter, web consolidation as well as total mass per unit area of the fabric. The results for the fibers produced at 206 kPa and 172 kPa meltblowing pressure is relatively same, but the values are higher compared to that produced at 241 kPa air pressure as shown in Fig. 6. This means that the strength of the webs is almost similar and as the meltblowing pressure decreases, the increase in the strength is not larger. The peak force for these fibers is about 12.7 kPa and an average elongation is about 13%. The breaking load increased with increasing die air pressure that could be due to the increase in basis weight and thickness. The elongation decreased with increasing die air pressure in the production direction, due to increase in the breaking load. The breaking load increased due to stronger bounding of the fibers in the web as a result of increasing air pressure applied to the web by the vacuum.

DSC scans of the pellets and the webs are shown in Figs. 7 and 8. Ultem being an amorphous polymer does not show any melting peaks, but glass transition temperature, which is relatively higher, that is the characteristic of this engineering plastic. The glass transition temperature of the Ultem 1285 pellets and the meltblown webs obtained from different processing conditions was the same and measured at 178 °C for heating and average of 185 °C for the cooling process. No significant difference in morphology was observed for the different meltblown samples as indicated by the DSC data. Accordingly, we observed the glass transition temperature in all the nonwoven samples at temperature close to that of the original polymer, only a few degrees lower due to the kinetic effect of the process as the finer fiber samples show better heat transfer due to higher surface area.

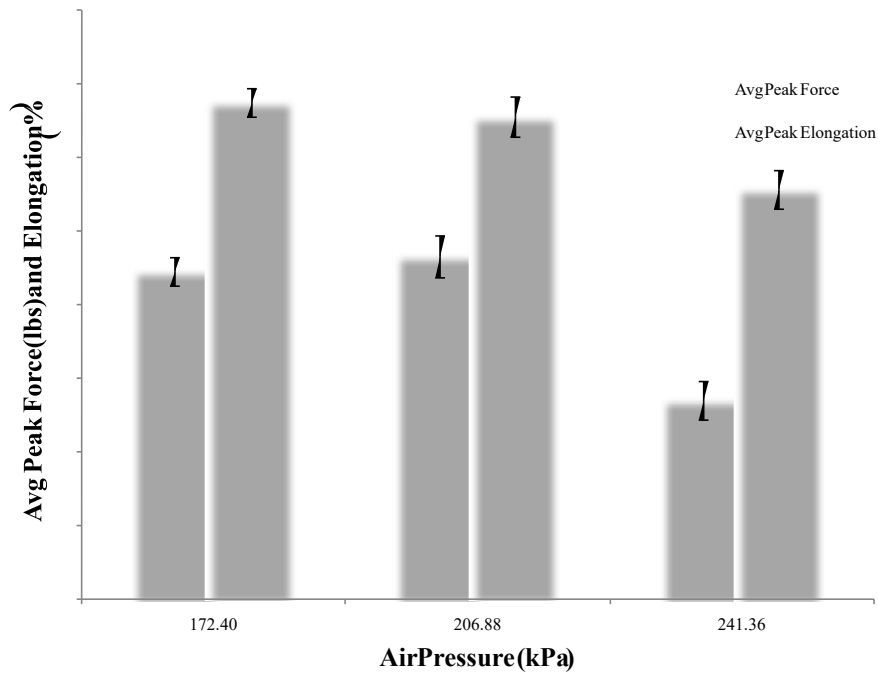

Fig. 6 Tensile strength and elongation of meltblown webs produced at different air pressures

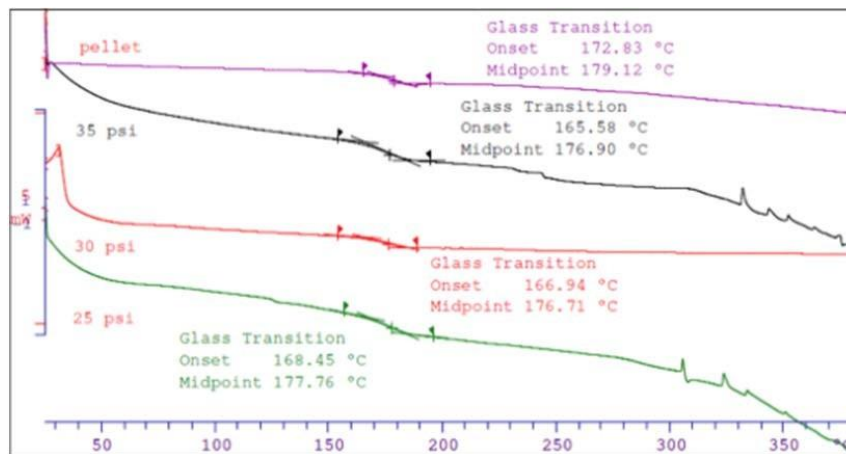

Fig. 7 DSC heating curve for Ultem 1285 pellets and fiberwebs produced under different processing

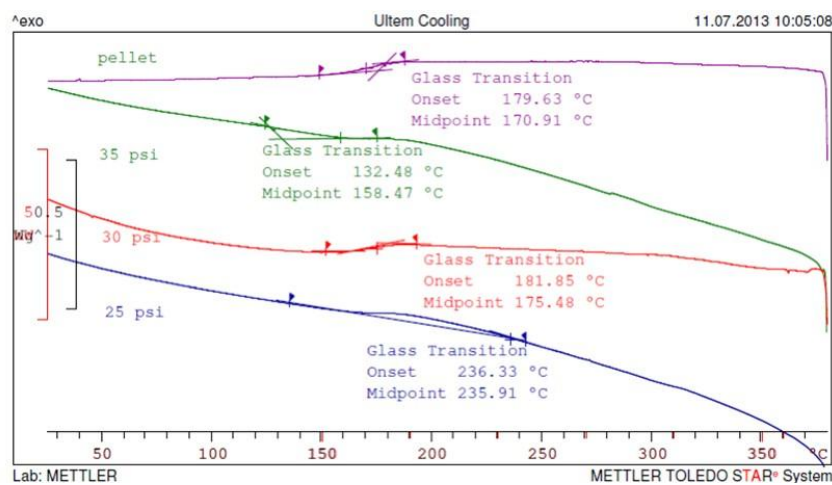

Fig. 8 DSC cooling curve for Ultem 1285 pellets and fiberwebs produced under different processing

IV. SUMMARY

In this work, we have fabricated fibrous filter media by meltblowing Ultem, which is a high temperature stable, high performance PEI, and investigated the structure and properties of the resulting meltblown webs. The microfibers were produced at different meltblowing air pressures and calenderer in order to reduce the pore size of the membrane by varying the process conditions. The fiber diameters varied by 8 to 13 microns depending on the air pressure used, and there were differences in air permeability as well as pore size of these webs as expected from differences in fiber diameters. It was further established that the separation characteristics of the resulting membrane can be changed by varying the calendering parameters that determine the pore size of the membrane, and therefore its permeability. These changes in structure and permeability also affect the performance of the membranes. This is a significant improvement in the mechanical filtration quality of the membrane [14]. It was clearly demonstrated that the filtration characteristics of the membranes formed from this high temperature polymer can be tailored by manipulating different meltblowing and further processing parameters to produce membranes with desired pore size for a specific filtration quality.

REFERENCES

- [1] Bhat, G.S. and Malkan, S. R., "Extruded continuous filament nonwovens: Advances in scientific aspects" *Journal of Applied Polymer Science*, 2002. 83(3): p. 572-585.
- [2] Wadsworth, L.C., and Malkan, S. R., "A Review of Melt Blowing Technology," *INB Nonwovens*, 1991: p. 2.
- [3] Bhat G. S. and Malkan S. R., "Polymer Laid Web Formation," in *Handbook of Nonwovens*, Woodhead Publishing, 2003, 760, p143.
- [4] Hegde, R. and Bhat, G. S., "Nanoparticle Effects on Structure and Properties of Polypropylene Meltblown Webs," *Journal of Applied Polymer Science*, 115 (2), 1062-1072 (2010).
- [5] Hiremath, N. and Bhat, G., "Melt blown Polymeric Nanofibers for Medical Applications-An Overview" *Nanosci Technol* 2 (1): pp 1-9 (2015).
- [6] Dai, Y., et al., "Ultem(RR)/ZIF-8 mixed matrix hollow fiber membranes for CO₂/N₂ separations" *Journal of Membrane Science*, 2012. 401: p. 76-82.
- [7] Bhat, G. S., Wapner, P. G. and Hoffman, W. P. "Processing of a high temperature imide copolymer into hollow fibers" *Materials and Manufacturing Processes*, 2000. 15(4): p. 533-545.
- [8] Han, W, Wang, X. and Bhat, G. S., "Structure and Air Permeability of Melt Blown Nanofiber Webs," *Journal of Nanomaterials and Molecular Nanotechnology*, 2013. 2:3.
- [9] Davies, G. M., Seaton, N. A., and Vassiliadis, V. S., "Calculation of pore size distributions of activated carbons from adsorption isotherms," *Langmuir*, 1999. 15(23): p. 8235-8245.
- [10] Yesil, Y. and Bhat, G. "Structure and Mechanical Properties of Polyethylene Melt Blown Nonwovens," *International Journal of Clothing Science and Technology*, 28 (6), 780-793 (2016). <http://dx.doi.org/10.1108/IJCST-09-2015-0099>.
- [11] Lee, Y. and Wadsworth, L. C., "Effects of Melt-Blowing Process Conditions on Morphological and Mechanical-Properties of Polypropylene Webs," *Polymer*, 1992. 33(6): p. 1200-1209.
- [12] Kandagor, C. V., "Nanolayer Polymeric Coatings to Enhance the Performance and Service Life of Inorganic Membranes for High Temperature-High Pressure Biomass Pretreatment and Other Applications," PhD Thesis, The University of Tennessee: Knoxville, TN. 2014.