

# Dynamics of Underwater Elastic Structures Using Graph Theory Modeling

Rohan Patel, Aarav Jain, Kavish Chauhan

*Institute of Marine Engineering, New Delhi, India*

**Abstract**—This paper presents modeling and simulation of flexible robot in an underwater environment. The underwater environment completely contrasts with ground or space environment. The robot in an underwater situation is subjected to various dynamic forces like buoyancy forces, hydrostatic and hydrodynamic forces. The underwater robot is modeled as Rayleigh beam. The developed model further allows estimating the deflection of tip in two directions. The complete dynamics of the underwater robot is analyzed, which is the main focus of this investigation. The control of robot trajectory is not discussed in this paper. Simulation is performed using Symbol Shakti software.

**Keywords**—Bond graph modeling, dynamics. modeling, Rayleigh beam, underwater robot.

## I. INTRODUCTION

THE need for the deep-sea exploration applications like debris removal, pipeline inspection, surveys, telecommunications support, research, maintenance, requires some technology which can venture down without any constraints. Underwater robots technology is the best solution to this because they are not bound to constraints like humans do. But there are problems in case of underwater robots. One of the major problems is trajectory control of the link because of various forces acting on the link thus deviating manipulator, arm from its desired trajectory. A dynamic model and an adaptive control system for a ROV are described followed by hydrodynamic testing of the vehicle [15]. Theory of adaptive plus disturbance observer (ADOB) controller for the underwater robots in order to tackle external disturbances and uncertainties in the system is discussed with experimental determination of effectiveness of ADOB controller [13]. The physical laws governing the dynamics of underwater vehicle considering the hydrodynamic forces is discussed using 3DOF robot [8]. Trajectory controller for an autonomous underwater vehicle under the influence of added mass, viscous drag, buoyancy force etc. using PD controller [11]. The mathematical modeling, control algorithm, system design, hardware implementation and experimental test of a Mantatype Unmanned Underwater Vehicle (MUUV) [6]. Ming-Jun Zhang and Zhen-Zhong Chu [9] addressed the trajectory tracking problem of the underwater robot using Lyapunov

theory. Indirect adaptive control method for an autonomous underwater vehicle manipulator system (UVMS) based on the extended Kalman Filter [12]. New region boundary-based tracking control for multiple Autonomous underwater vehicles (MAUVs) [16].

The bond graph techniques offers flexibility in modeling and formulation of system equations of dynamic systems. The various branches of engineering can be modeled in a unified manner using bond graph. The bonds depict the power exchange in the system. Power is expressed as the multiplication of force and effort, both being directed in opposite direction. The main elements of bond graph modelling comprises of instances (I), compliances (C), and dissipations (R). The input to the system can be defined by source of effort (SE) and source of flow (SF). The multi-port elements like transformers (TF) and gyrators (GY) are also used. Transformers are used for effort to effort or flow to flow mapping whereas gyrators are used for flow to effort or effort to flow mapping. Constraints are represented by 1 element or 0 elements depicted either constant flow or constant effort respectively. All these elements are connected by line segments known as bonds which show the direction of power exchange [2].

This paper presents the modeling and simulation of underwater flexible robot as Rayleigh beam. Bond graph technique [1], [3]-[5], [7] is used for both modeling the flexible robot as well as to ascertain its underwater dynamics

## II. MODELING OF RAYLEIGH BEAM

Rayleigh beam model is advanced form over the EulerBernoulli model with the incorporation of rotary inertia. The effect of shear deformation is neglected in this model and accounted in the Timoshenko beam model. Robotic manipulator is usually modelled as beams. Beams are the structural members which are under the influence of various forces. The problems occurs in system modeling when lumping of inertia and compliance fails to satisfy the dynamics of the flexible system as in the case of rigid bodies. Flexibility of the beam plays an important role in the dynamics of the system. These structural members are governed by partial differential equations and are lumped in space for finite approximation.

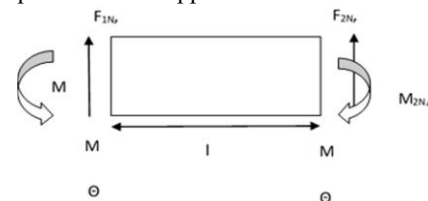

Fig. 1 Beam element with generalized forces and displacement

The stiffness of the beam element gives the relation between generalized Newtonian forces and generalized displacement at the end of the beam element by

(1)

In terms of flexural rigidity  $EI$  and beam length  $l$  the stiffness matrix is given by equation

$$\begin{bmatrix} 12 & 6 & 12 & 6 \\ -6 & 4 & 6 & 2 \\ 12 & 6 & 12 & 6 \\ 6 & 2 & 6 & 4 \end{bmatrix} \quad (2)$$

The bond graph element of the beam element can be created by lumping the element inertias at the ends of the elements and joining them to 1-junctions which represents linear and rotary displacements.

A cantilever beam with reticulation and lumping of inertia is shown in Fig. 2 and its bond graph is shown in Fig. 3



Fig. 2 Cantilever beam with space reticulation and inertia lumping

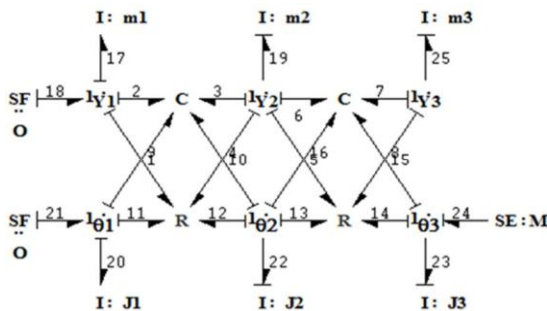

Fig. 3 Bond graph model of reticulated beam

Lumped linear inertia may be obtained as:

$$m = \rho A l$$

where,  $\rho$  is the density of the material of beam and  $A$  is the cross-sectional area.

The lumped rotary inertia may be calculated as

$$J = \frac{\rho A l^3}{12}$$

where,  $I$  is the second moment of the beam cross-sectional area about the neutral axis[10].

### III. MODELING OF FLEXIBLE UNDERWATER ROBOT

A robotic manipulator in the underwater environment experiences forces which alters the dynamics of the surface or space robots. The situation becomes more critical with increase in the depth of dive. Various control strategies can be applied for the control of the underwater manipulator.

The dynamic model of underwater manipulator vehicle system is given by:

$$M \ddot{q} + C \dot{q} + W + D \dot{q} = V + \tau \quad (3)$$

where,  $\tau$ : External input forces and torques,  $M$ : Mass and added mass-inertia matrices,  $C$ : Coriolis and centripetal matrices,  $W$ : Buoyancy force matrix,  $D$ : Damping forces,  $V$ : Linear velocity matrix,  $\omega$ : Angular velocity matrix

The effect of added mass and damping forces is neglected in the final model. The motion of rigid body in the underwater environment requires consideration of number of factors arising due to hydrostatic and hydrodynamic effects. The hydrostatic force is due to pressure of water in the underwater robot vehicle. And hydrodynamic forces are 1) forces and moments comprising added mass, 2) Environmental forces like ocean currents, waves, wind etc. and 3) propulsion force. Environmental forces have not been considered in present work. For robots moving at depth of 30m, the effect of surface waves is ignored. For simplification net hydrodynamic force on body can be represented as combined effect of drag, fluid, acceleration, buoyancy. It is assumed that fluid is irrational, unbounded and still. Figs. 4 and 5 show the schematic diagram of 1 DOF flexible manipulator and its bond graph model in underwater situation.

The kinematics relations developed in the previous sections are used to draw bond graph of the flexible manipulator arm. The bond graph of the underwater flexible manipulator is composed of three sections i.e. base, joint and flexible arm. The flow activated bonds 31 and 38 represents the linear and rotary inertia of the vehicle base. The arm is modelled as Rayleigh beam and is assumed to have two reticulated of equal length ( $l$ ). The lumping of mass is done at the extreme end of the beam and at the interface of reticulates. Motor is mounted at the base. The one end of the arm is connected to the motor and the tip of the manipulator is assumed to be free. The torque provided by motor ( $\tau$ ) is represented by SE (27). Let  $\phi$  be the rotation of the vehicle frame with respect to absolute frame and  $\theta$  is the joint angle. The mass of the motor is assumed to be  $m_1$ . The motor applies the torque ( $\tau$ ) on link. The link is assumed to have uniform flexural rigidity ( $EI$ ) and cross-sectional area ( $A$ ).

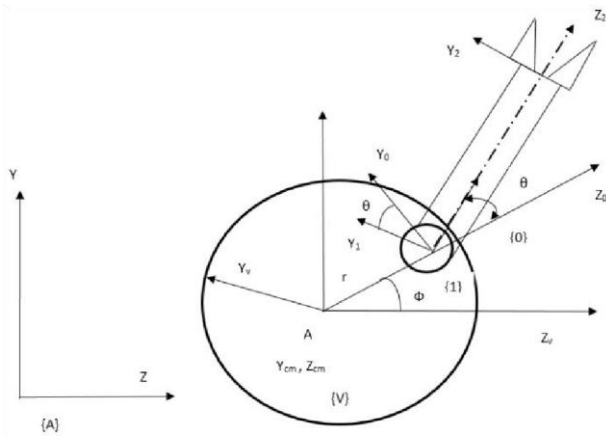

Fig. 4 Schematic diagram of 1 DOF flexible manipulator

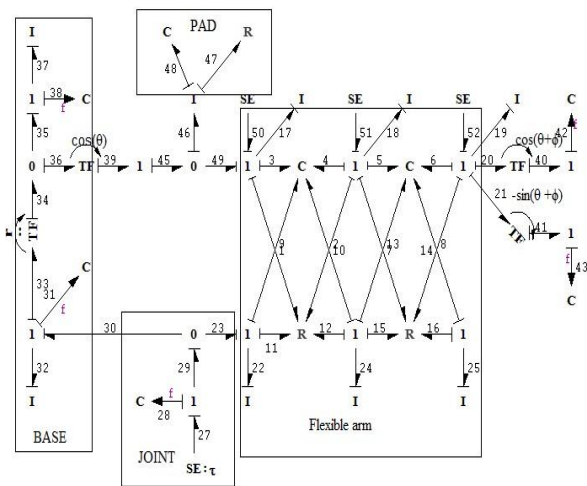

Fig. 5 Bond graph model of underwater flexible robot

The length of the link is equally divided in to two reticulates and these are represented by two C-fields and two R-fields represents the internal damping of the beam. SE (50, 51, and 52) represents the forces exerted on the manipulator under the water viz. buoyancy, gravity and hydro-static forces. The pads are used to avoid differential causality of the model. Transformers used here shows from relation between Flow to flow and effort to effort. The tip velocity of the manipulator ( $Y_{tip}$ ,  $Z_{tip}$ ) is shown by bond 42 and 43.

#### IV. SIMULATION AND RESULTS

The simulation for underwater flexible manipulator is carried out using SYMBOLS SHAKTI/SONATA [14] software. It is assumed that the motor provides the torque 1Nm to joint. The initial value of  $\phi$  and  $\theta$  is 0.1 and 0.2 radian. The simulation is carried out for 5 second for getting results. The parameters used simulations are given below in Table I.

Fig. 6 shows the variation of joint angle with respect to time. It decreases continuously with respect to time and reaches to value of -1.03 radians in 5 seconds.

TABLE I  
PARAMETERS USED FOR SIMULATION OF ONE ARM FLEXIBLE UNDERWATER ROBOT

S.No.	Parameter	Nomenclature	Values
	Modulus of Elasticity	E	$70 \times 10^4$ 5/
	Link Length	l	0.45 m
	Moment of inertia of crosssection of link	I	$1.525 \times 10^9$ ;
	Motor torque	$\tau$	1Nm
	Density of Aluminium (alloy)	$\rho$	2700 "
	Cross section area of link	A	$1.5 \times 10^9$ "
	Acceleration due to gravity	g	10 >/
	Mass of link	$M_{link}$	1kg
	Volume of link	$V_{link}$	$8 \times 10^9$ ;"
	Radius of base	r	0.9 m

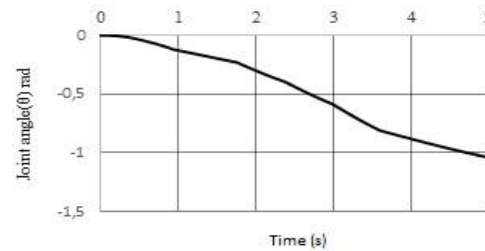

Fig. 6 Variation in Joint angle ( $\theta$ ) with respect to Time

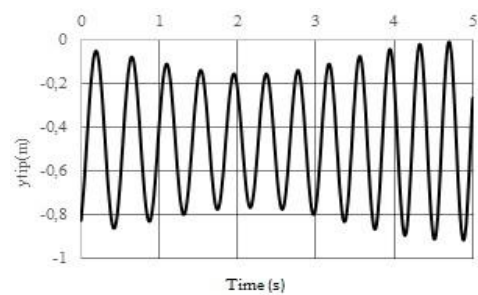

Fig. 7 Tip deflection in Y direction with respect to Time

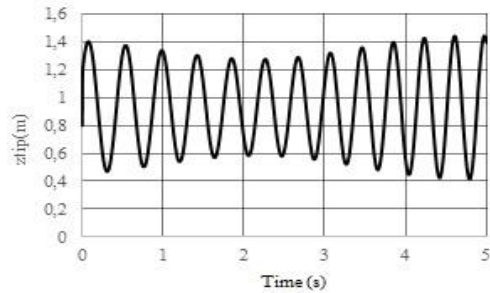

Fig. 8 Tip deflection in Z direction with respect to Time

Fig. 7 shows the variation of tip position in Y direction with respect to time. The initial position of  $Y_{tip}$  is  $-0.82$  m at  $T=0$  sec. The behaviour of variation of tip is sinusoidal with respect to time. The maximum amplitude observed is  $-0.91$  m. and Fig. 8 shows the tip position in Z direction with respect to time. The initial position of  $Z_{tip}$  is  $0.8$  m at  $T=0$  sec. and it follows sinusoidal motion with variation in amplitude. The maximum amplitude observed is of  $1.428$  m and the varying sinusoidal behavior is observed due to nonholonomic system. This disturbance can be controlled by attitude controlled device like overwhelming controller.

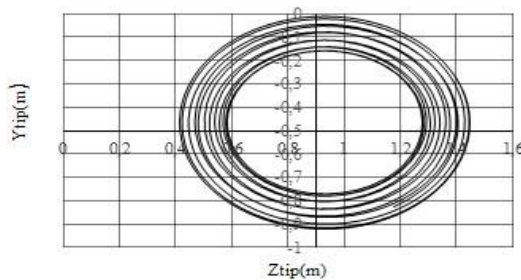

Fig. 9 Tip Trajectory of one arm flexible underwater robot

Fig. 9 shows the tip trajectory of the underwater manipulator as circle. The radius of the circle is equivalent to the length of manipulator arm. The variation in rotation is due to non-inertial underwater robot system.

#### V. CONCLUSION

This paper shows the modeling of underwater flexible robot as a RAYLEIGH beam which is more advanced than Euler Bernoulli beam. The model consist of base and flexible arm, the flexible arm has two reticulates. The dynamic situation is considered by involving the effect of gravity, buoyancy and hydrostatic forces. The model is developed and simulated using bond graph technique. The simulation is carried out for 5 sec and the simulation stops after that because system reaches point of singularity.

#### REFERENCES

[1] K. Ghosh, (1990), "Dynamics and Robust Control of Robotic Systems: A Bond Graph Approach", PhD thesis, Department of Mechanical Engineering, Indian Institute of Technology, Kharagpur.  
[2] Amalendu Mukherjee et al. (2006), "Bond graph in modeling, simulation and fault identification", I.K international publishing house Pvt. Ltd., New Delhi.

[3] Breedveld, P. C. and Dauphin-Tanguy, G., (1992), "Bond Graphs for Engineers", North-Holland, Amsterdam.  
[4] Brown, F. T., (2001), "Engineering System Dynamics", Marcel Dekker, Inc, New York.  
[5] Gawthrop, P. and Smith, L., (1996), "MetaModeling: Bond graphs and Dynamic Systems", Prentice-Hall.  
[6] Hyeong-Dong Kim, Seung-Woo Byun, Seung-Keon Lee, Joon-Young Kim, Taek Soo Jang and Hang S. Choi, (2011), "Mathematical Modeling and Experimental Test of Manta-type UUV", IEEE.  
[7] Karnopp, D. C., Rosenberg, R. C. and Margolis, D. L., (1990), "System Dynamics: A Unified Approach", John-Wiley and Sons Inc., USA.  
[8] Kedar S. Dixit and P. M. Pathak, (2007), "Modeling and simulation of 3 DOF underwater robot", Recent Advances in Design Dynamics and Manufacturing (NCDDM-2007), 137-145.  
[9] Ming-jun Zhang, Zhen-zhong Chu (2012), "Adaptive sliding mode control based on local recurrent neural networks for underwater robot", J. ocean engineering 45 (2012) 56-62.  
[10] Mukherjee, A. and Karmakar, R., (2000), "Modeling and Simulation of engineering System through Bond Graph", Narosa publishing House, New Delhi, reprinted by CRC press for North America and by Alpha Science for Europe, PP,203-207.  
[11] Periasamy T., Asokan T., Singaperumal M., (2008), "Controller Design for Manipulator Trajectory Control of an AUV- Manipulator System" Third International Conference on Industrial and Information Systems, Kharagpur, INDIA, Paper Identification Number 474, 1-6.  
[12] Santha kumar Mohan, Jinwhan Kim (2012), "Indirect adaptive control of an autonomous underwater vehicle-manipulator system for underwater manipulation tasks", J. ocean engineering 54 (2012) 233-243.  
[13] Side Zhao and Junku Yuh, (2005), "Experimental Study on Advanced Underwater Robot Control", IEEE Transactions on Robotics, Vol. 21, NO. 4.  
[14] Yuh J., (1990), "Modeling and Control of Underwater Robotic Vehicles", Transactions on Systems, Man, and Cybernetics, Vol. 20, No. 6, 1475-1483.  
[15] Zool H. Ismail (2012), "Tracking Control Scheme for Multiple Autonomous Underwater Vehicles Subject to Union of Boundaries", Procedia Engineering 41 (2012), 1176 – 1182.