

Non-Invasive Cardiovascular Monitoring Systems

E. Kuznetsova, A. Denisov

Russian Academy of Medical Sciences, Moscow, Russia

Abstract—In this paper, we report the development of the device for diagnostics of cardiovascular system state and associated automated workstation for large-scale medical measurement data collection and analysis. It was shown that optimal design for the monitoring device is wristband as it represents engineering trade-off between accuracy and usability. Monitoring device is based on the infrared reflective photoplethysmographic sensor, which allows collecting multiple physiological parameters, such as heart rate and pulsing wave characteristics. Developed device uses BLE interface for medical and supplementary data transmission to the coupled mobile phone, which processes it and send it to the doctor's automated workstation. Results of this experimental model approbation confirmed the applicability of the proposed approach.

Keywords—Cardiovascular diseases, health monitoring systems, photoplethysmography, pulse wave, remote diagnostics.

I. INTRODUCTION

THE rapid development of biological sciences and technologies makes health care system more streamlined and efficient. There is a steady trend to shift from the conventional clinic-based diagnosis to adoption of various individual health monitoring systems [1]. This trend will likely increase over time due to global population aging.

Consequently, broad-scale utilization of affordable and easy to use remote medical testing and electronics diagnosis solutions will decrease load of the public health system and promote the popularity of the periodic health self-checks.

Portable device for individual ambulatory monitoring can be used to provide timely support for patients with cardiovascular disease, which is the most common chronic disease among the population. At present time, the standard procedure for the cardiovascular disease diagnosis is electrocardiography. Regular electrocardiogram acquisition is relatively laborious process and cannot be used for long-term monitoring without significant interference with everyday life.

According to the recent research results, photoplethysmography (PPG) technology is a promising approach for individual cardiovascular monitoring systems design [2], [3]. The main advantages of PPG over electrocardiography are single sensor scheme and the lack of the necessity of electrodes with gel. PPG is a noninvasive

optical technology that detects changes in blood volume in the blood vessels and allows estimating state of cardiac function by

measuring the heart rate variability. Generally, PPG-based medical devices for long-term monitoring are easy to place and allow monitoring of multiple physiological parameters, such as heart rate, pulse wave characteristics, blood oxygen level, etc.

II. RESULTS AND DISCUSSION

The main goal of this work was to create a system which makes cardiovascular state monitoring process more efficient and comfortable for both patient and physician. For this purpose we designed PPG-based portable monitoring device and doctor's automated workstation. Fig. 1 shows a general operation concept of designed system. Portable monitoring device collect data concerning cardiovascular state (heart rate, pulse wave parameters) and supplementary data (temperature, movements). Collected data is transmitted via BLE to the coupled mobile phone, which reduces it and sends to the doctor's automated workstation. Essentially, workstation is hardware independent piece of software, which can be cloud or local hosted. It provides archival storage of medical data for all patients, statistical tools for data analysis and cardiovascular disease prediction and web interface for physician.

PPG is cardiac parameters estimation technique based on the intensity measurements of light which passes through the biological tissues. Light source wavelength is chosen in such a way that blood absorbs more infrared light than surrounding tissues. Thus, decrease of blood volume is detected as an increase in intensity of the detected light and vice versa. The highest possible blood volume changes occur in arteries and arterioles.

Fig. 2 shows a schematic representation of PPG signal origin. Signal consists of a constant component and variable component. Constant component is defined by the tissues structure, average volume of the arterial and venous blood and varies slowly with the breath. Variable component indicates the blood volume changes between the systolic and diastolic phases of the cardiac cycle. Basic frequency of variable component depends on heart rate. The peak of the pulse wave corresponds to the maximum blood volume, and the bottom corresponds to the smallest blood volume in the examined tissue site. The pulse waveform is dependent on the vascular walls elasticity, the pulse rate, the width of the vessel flow area. It is commonly supposed that the frequency, shape and duration of the pulse wave is dependent on the heart properties, and therefore the state of the cardiovascular system

can be estimated by the form of a pulse wave [4], [5].

The interaction of light with these tissues is quite complex and involve processes of scattering, absorption and reflection. Researches on light penetration in human skin [6]–[8] showed that the main peak of visible range absorption is located in the blue part of the spectrum and correspond to absorption by melanin in human skin. Spectrum range between 500 nm and 600

nm is associated with red blood cells adsorption. There are also water adsorption peaks in infrared and ultraviolet regions, whereas red and near-infrared light passes tissues with minimal interaction. Apparently, wavelength defines the depth of light penetration. Green light is best suited for measuring blood flow in the skin, yellow light is appropriate for subsurface tissue perfusion measurements and infrared and near-infrared light is ideal for measuring the blood flow in deep lying tissues (e.g. blood flow in the muscles). Taking all the aforesaid into consideration, infrared light based sensor is considered optimal for intended application purposes [9].

Common PPG sensor consists of an LED-based light source and photodetector. Photodetector measures changes in intensity of light reflected from living tissue, which are associated with small changes of tissue blood perfusion and used for the heart rate and the pulse wave parameters estimation [10], [11].

There are two basic types of sensors: transmittive and reflective. In transmittive sensor photodetector is faced to the light source in such a way that light passes through tissues directly to detector. In reflective mode source and photodetector are located side to side so that detector is exposed to reflected light only. Transmission regime provide relatively good signal but also apply restrictions to the possible sensor location areas. Efficient operation of this type of sensor is possible only for positions where the transmitted light can be steadily detected. Preferred sites are fingertip and earlobe, although these places have limited blood perfusion and susceptible to changes of environmental conditions such as low temperature. Furthermore, the biggest drawback of this type of sensors is sense of discomfort during daily activities. Reflective sensor eliminates the location problems and expands number of possible body sites. However, it is liable to motion and contact pressure artifacts. Any movement, including any physical activity, leads to the corruption of PPG signal and limits the accuracy of the physiological parameter measurements.

In order to determine optimal position of reflective sensor the mockup of the monitoring device was created. Prototype consists of TCRT1000 infrared optical sensor, analog high pass filter, LM324 operational amplifier, and microcontroller board Arduino UNO, which is used for analog-to-digital conversion and computer communication. PPG pulse wave signal from two male healthy volunteers were studied. Sensor application areas were nose bridge, earlobe, fingers and wrist with total sample size of 600 for each subject. Collected experimental data showed that the lowest number of artifacts is exhibited by data obtained from earlobe tissues, however common ways of attachment of device to earlobe are impractical for everyday use. In this context, wristband style form-factor was chosen for technical implementation because it represents engineering trade-off between accuracy and usability.

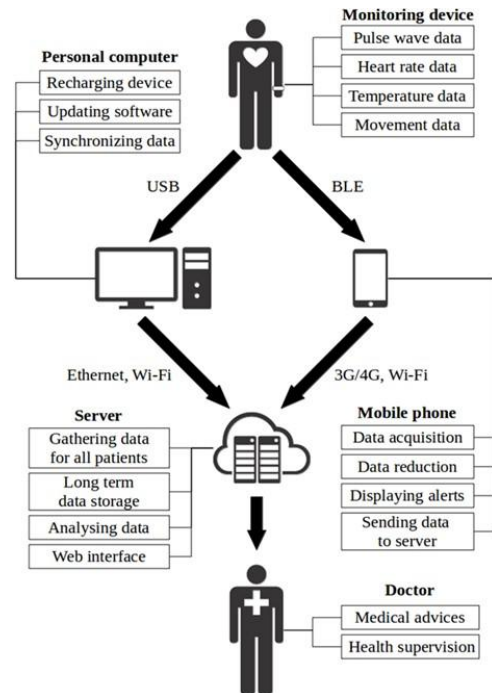

Fig. 1 Structure and functions of health monitoring system

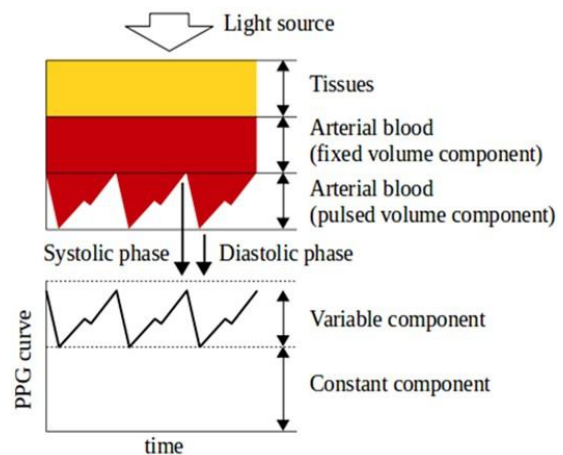

Fig. 2 Light attenuation in human tissues

As part of our applied scientific research, experimental model of the device for diagnostics of cardiovascular system state and associated automated workstation for large-scale medical measurement data collection and analysis were developed.

Monitoring device was designed to be energy-efficient in order to maximize battery life. Most of the time device is in sleep mode with peripheral modules disconnected. Every five minutes it wakes up, collect cardiovascular and supplementary data for one minute and send it to server. Structure of the device is shown in Fig. 3. Developed device consists of the following modules: data acquisition module, communication module, power management module and user interaction module. Data acquisition module consists of DCM03 dual wavelength (660 nm and 940 nm) infrared reflective PPG sensor, AFE4403 analog front-end, MPU-9150 accelerometer, MSP430F5528 low power microcontroller and flash memory. Analog front-end provide LED control, fault

detection and analog-to-digital conversion. Accelerometer data is to be used for artifact filtering. Flash memory serves to store data in case of wireless data channel inaccessibility. Communication module provides USB and BLE interfaces. User interaction module provides indication for low power and emergency situations.

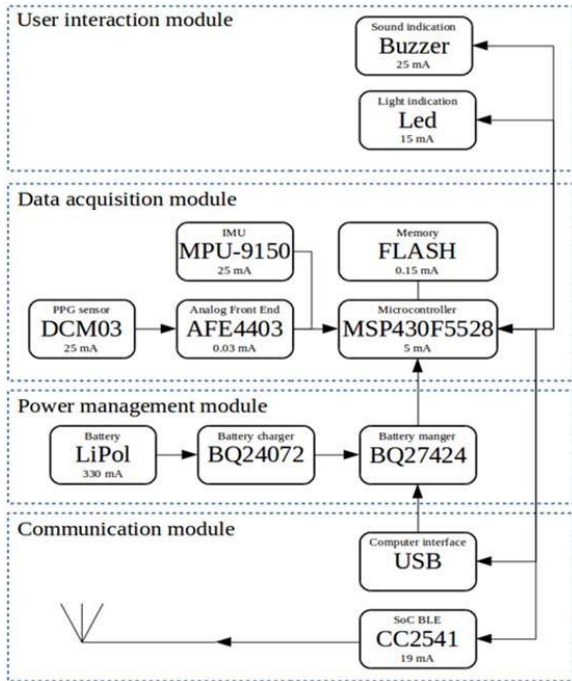

Fig. 3 Structure and basic components of the developed monitoring device

Prototype of the health monitoring device was designed, assembled and tested. Fig. 4 shows design of developed six-layer printed circuit board (PCB) for main data acquisition module. Design follows system-on-board approach. PCB

layers are: top signal plane, mixed analog and digital ground plane, two signal planes, power plane and bottom signal plane. DCM03 sensor is located at the left part of PCB and connected to the AFE4403 analog front-end microchip right next to it. AFE4403 is connected to the MSP430F5528 microcontroller via SPI interface. On the right part of PCB there is edge board connector, which is used for final device assembling.

Manufactured PCB for device prototype was tested via Xray micro tomography (XMT). PCB size is 15.47×10.49×0.6 mm, copper height for inner planes is 18 μm, track/gap size is 0.1/0.1 mm. XMT allows to reveal most of multilayer PCB defects undetectable by optical methods. Test showed no manufacturing defects. X-ray image is shown at Fig. 5.

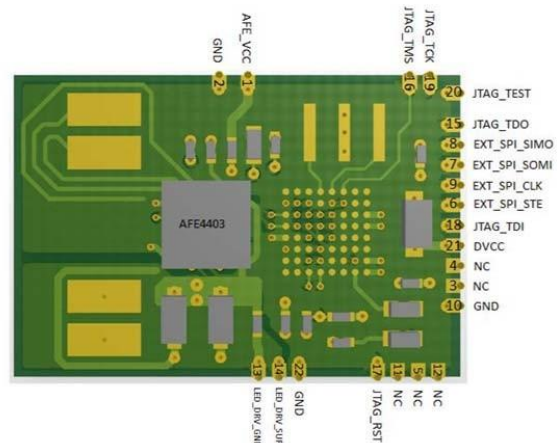

Fig. 4 Rendered PCB of the developed monitoring device

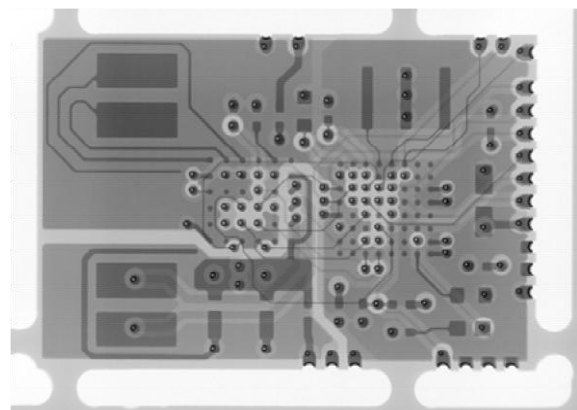

Fig. 5 X-ray image of the PCB for device prototype

Obtained with device prototype raw PPG data, displayed in Fig. 6, is a typical PPG curve with distinguishable systolic notch. Evidently, quality of experimental data is sufficient for

pulsed parameters. Present noise is normal because resource-intensive filtering function is delegated to other devices for the sake of energy consumption reduction.

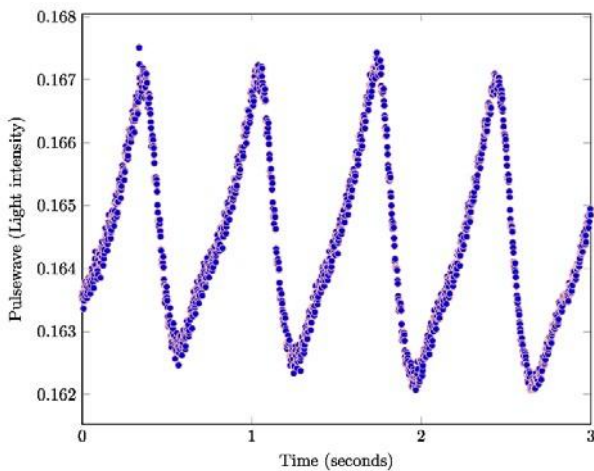

Fig. 6 PPG signal, measured by experimental device

Software part of the system follows the concept of Mobile Health. Monitoring device is connected to the mobile phone which passes data to server or cloud based service, which in turn process data and send notifications to user when it becomes necessary. Medical data with statistical analysis results are accessible to physician via web application. Thus, system consists of the following essential components:

application for smartphone, server service and web administration application.

Device microcontroller firmware is written in ANSI C99. It ensures the functioning of PPG unit: initial setup, sensor calibration and data transfer via Bluetooth transceiver. Smartphone application is written in C# for Windows Phone 8.1 operating system. Application provides data transfer from the smartphone to remote server and emergency situation user alerts. Doctor's automated workstation is written in Ruby 2.0 (Rails 4.2.1) with PostgreSQL 9.3 as data storage. At this point doctor's automated workstation web application provides basic functionality: user management with access control, medical data receiving, storing and graphical representation.

Fig. 7 shows user interface of doctor's automated workstation. The graph shows average heart rate per time unit. Under the graph there is a table, which provides links to more detailed information for each observation (raw PPG data). There are also graphs for pulse wave parameters.

III. CONCLUSIONS

The approach for PPG-based cardiovascular state monitoring system was proposed and implemented in the experimental model. Approval of the model confirmed the applicability of the chosen design. Future work will focus on diagnostic device size reduction and development of specialized software, which will allow identifying the early course of cardiovascular diseases basing on statistical analysis of physiological parameters.

Fig. 7 User interface of doctor's automated workstation

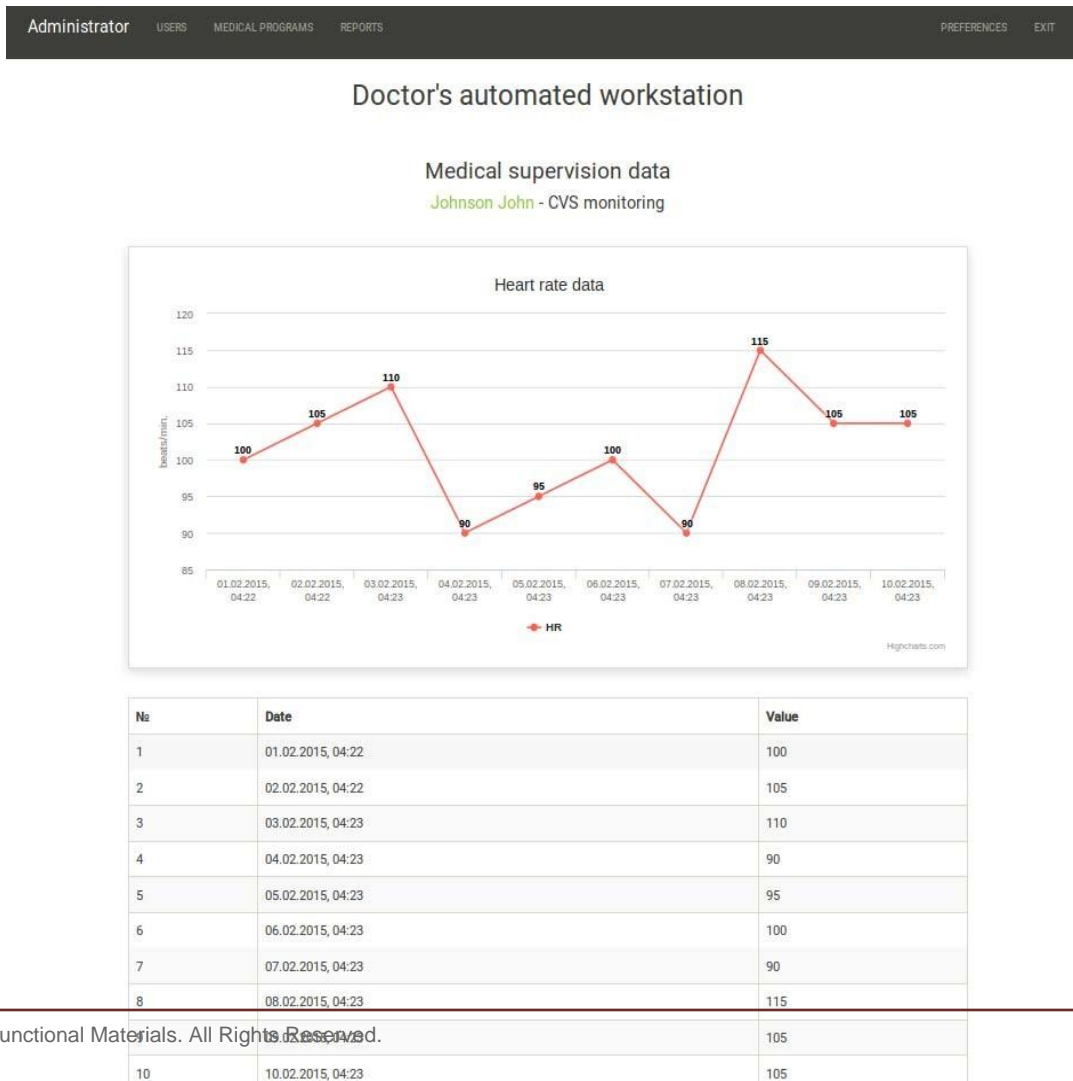

REFERENCES

- [1] Lee, Drew E., and Richard S. Cooper. "Recommendations for Global Hypertension Monitoring and Prevention." *Current Hypertension Reports* 11, no. 6, 2009, 444-449.
- [2] Chang, F. C., C. K. Chang, C. C. Chiu, S. F. Hsu, and Y. D. Lin. "Variations of HRV Analysis in Different Approaches." In *Computers in Cardiology*, 2007, pp. 17-20. IEEE, 2007.
- [3] Allen, John. "Photoplethysmography and Its Application in Clinical Physiological Measurement." *Physiological measurement* 28, no. 3, 2007, R1.
- [4] Nam, Dong-Hyun, Woo-Beom Lee, You-Sik Hong, and Sang-Suk Lee. "Measurement of Spatial Pulse Wave Velocity by Using a Clip-Type Pulsimeter Equipped with a Hall Sensor and Photoplethysmography." *Sensors* 13, no. 4, 2013, 4714-4723.
- [5] Lee, Sang-Suk, Myoung-Chone An, and Sung-Hoon Ahn. "A New Measurement Method of a Radial Pulse Wave Using Multiple Hall Array Devices." *Journal of Magnetism* 14, no. 3, 2009, 132-136.
- [6] Cui, Weijia, Lee E. Ostrander, and Bok Y. Lee. "In vivo Reflectance of Blood and Tissue as a Function of Light Wavelength." *Biomedical Engineering, IEEE Transactions on* 37, no. 6, 1990, 632-639.
- [7] Zijlstra, W. G., A. Buursma, and W. P. Meeuwse-Van der Roest. "Absorption Spectra of Human Fetal and Adult Oxyhemoglobin, Deoxyhemoglobin, Carboxyhemoglobin, and Methemoglobin." *Clinical chemistry* 37, no. 9, 1991, 1633-1638.
- [8] Maeda, Yuka, Masaki Sekine, and Toshiyo Tamura. "The Advantages of Wearable Green Reflected Photoplethysmography." *Journal of medical systems* 35, no. 5, 2011, 829-834.
- [9] Giltvedt, J., A. Sira, and P. Helme. "Pulsed Multifrequency Photoplethysmograph." *Medical and Biological Engineering and Computing* 22, no. 3, 1984, 212-215.
- [10] Challoner, A. V. J. "Photoelectric Plethysmography for Estimating Cutaneous Blood Flow." *Non-Invasive Physiological Measurements* 1, 1979, 125-151.
- [11] Korpas, D., J. Halek, and L. Dolezal. "Parameters Describing the Pulse Wave." *Physiological research* 58, no. 4, 2009, 473.